

BI-DIRECTIONAL DC MOTOR DRIVER

The KA8301 is a monolithic integrated circuit designed for driving bi-directional DC motor with braking and speed control, and it is suitable for the loading motor driver of VCR systems. The speed control can be achieved by adjusting the external voltage of the speed control pin.

FEATURES

- Built-in brake function for stable brake characteristics.
- Built-in element to absorb a dash current derived from changing motor direction and braking motor drive.
- External motor speed control pin
- Stable motor direction change.
- Interfaces with CMOS devices.

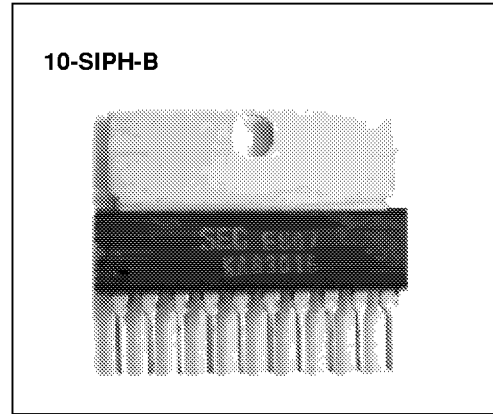

ORDERING INFORMATION

| Device | Package | Operating Temperature |
|--------|-----------|-----------------------|
| KA8301 | 10-SIPH-B | -25°C ~ +75°C |

TARGET APPLICATION

- VCR
- Low current DC motor such audio equipment

BLOCK DIAGRAM

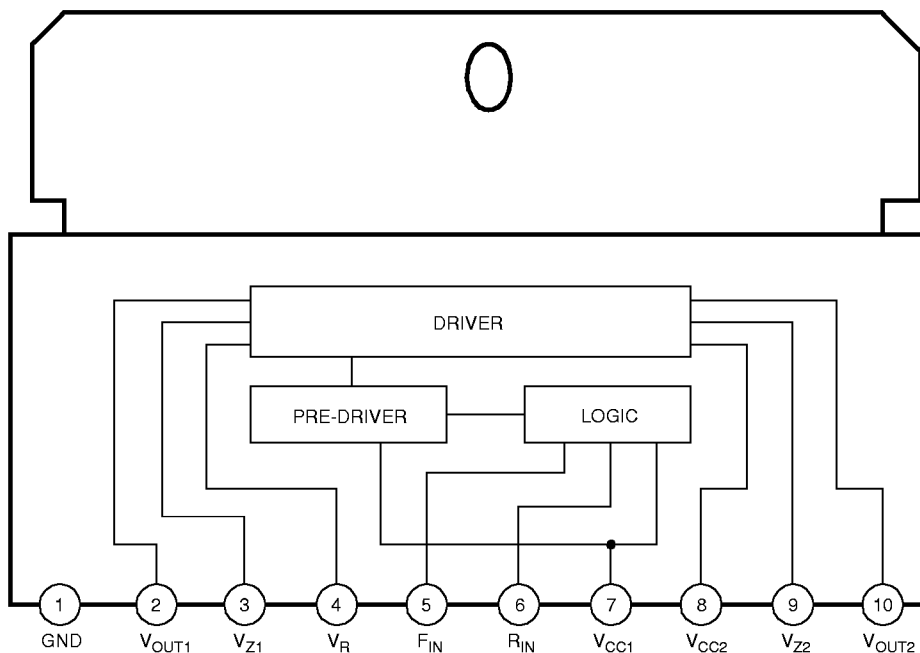

PIN CONFIGURATIONS

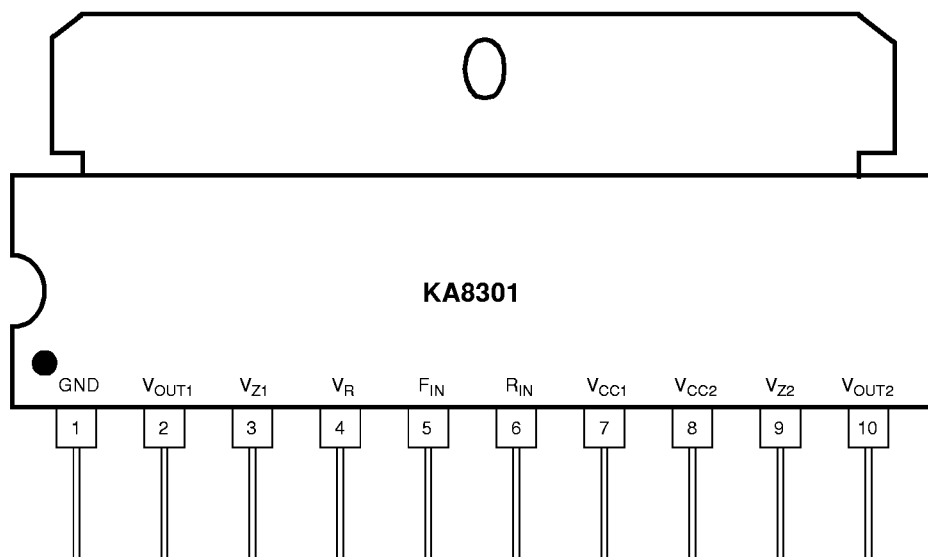

PIN DESCRIPTION

| Pin No. | Symbol | I/O | Description | Pin No. | Symbol | I/O | Description |
|---------|------------|-----|---------------------|---------|------------|-----|-------------------------|
| 1 | GND | – | Ground | 6 | R_{IN} | I | Input 2 |
| 2 | V_{OUT1} | O | Output 1 | 7 | V_{CC1} | – | Supply voltage (Signal) |
| 3 | V_{Z1} | – | Phase compensation | 8 | V_{CC2} | I | Supply voltage (Power) |
| 4 | V_R | I | Motor speed control | 9 | V_{Z2} | I | Phase compensation |
| 5 | F_{IN} | I | Input 1 | 10 | V_{OUT2} | O | Output 2 |

INTERNAL CIRCUIT

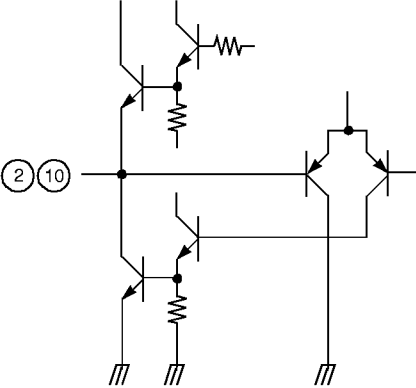
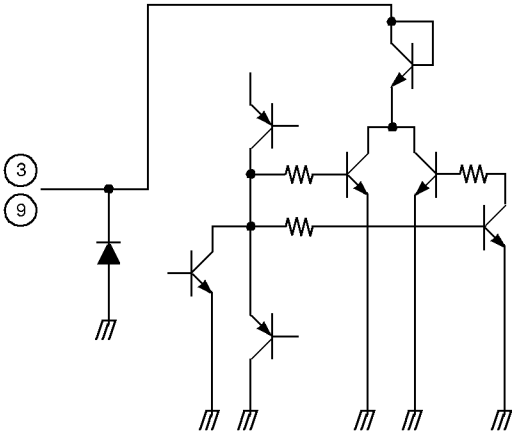
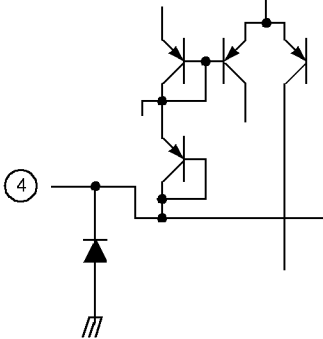
| Description | Pin No. | Internal circuit |
|--------------------|---------|--|
| Output | 2, 10 |  |
| Phase compensation | 3, 9 |  |
| Speed control | 4 |  |

INTERNAL CIRCUIT (Continued)

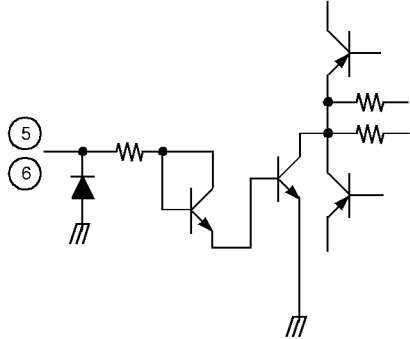
| Description | Pin No. | Internal circuit |
|--------------|---------|--|
| Input | 5, 6 |  |
| SVCC PVCC | 7 8 | |
| GND | 1 | |

ABSOLUTE MAXIMUM RATING (Ta=25°C)

| Characteristics | Symbol | Value | Unit |
|------------------------|-------------|----------------------|------|
| Supply voltage | V_{CCmax} | 18 | V |
| Maximum output current | I_{Omax} | 1.6 ^{note1} | A |
| Power dissipation | P_d | 15 ^{note2} | W |
| Input voltage | V_{IN} | -0.3 ~ V_{CC} | V |
| Operating temperature | T_{OPR} | -25 ~ +75 | °C |
| Storage temperature | T_{STG} | -55 ~ +150 | °C |

NOTES:

- Duty 1/100, pulse width 500μs
- 1) When mounted on glass epoxy PCB (76.2 × 114 × 1.57mm)
- 2) Power dissipation reduces 120mW / °C for using above Ta=25°C
- 3) Do not exceed Pd and SOA.

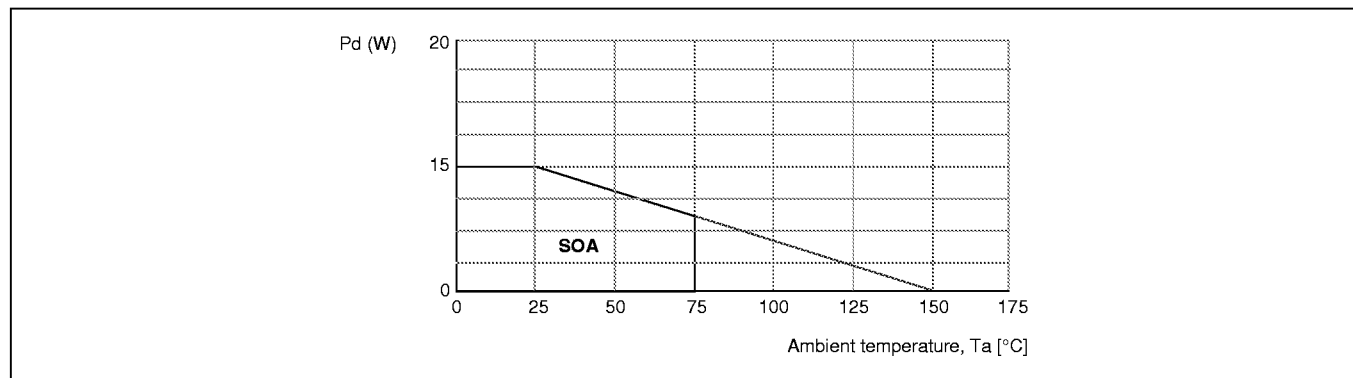
PD GRAPH**RECOMMENED OPERATING CONDITIONS (Ta=25°C)**

| Characteristics | Symbol | Value | Unit |
|--------------------------|----------|--------|------|
| Operating supply voltage | V_{CC} | 8 ~ 18 | V |

ELECTRICAL CHARACTERISTICS ($T_a=25^\circ\text{C}$, $V_{CC}=12\text{V}$)

| Characteristic | Symbol | Test conditions | Min. | Typ. | max. | Unit |
|------------------------------|--------------|---|------|------|------|---------------|
| Quiescent current | I_Q | Pin5 & 6: GND, $R_L=\infty$ | 3 | 5.5 | 20 | mA |
| Min. input-on current 1 | I_{IN1} | $R_L=\infty$, pin5= I_{IN1} , pin6=L | – | 10 | 50 | μA |
| Min. input-on current 2 | I_{IN2} | $R_L=\infty$, pin5=L, pin6= I_{IN2} | – | 10 | 50 | μA |
| Input threshold voltage 1 | V_{INTH1} | $R_L=\infty$, pin5= V_{INTH1} , pin6=L | 0.7 | 1.3 | 2.0 | V |
| Input threshold voltage 2 | V_{INTH2} | $R_L=\infty$, pin5=L, pin6= V_{INTH2} | 0.7 | 1.3 | 2.0 | V |
| Output leakage current 1 | I_{OL1} | $R_L=\infty$, pin5 & 6=GND | – | – | 1 | mA |
| Output leakage current 2 | I_{OL2} | $R_L=\infty$, pin5 & 6=GND | – | – | 1 | mA |
| Zener current 1 | I_{Z1} | $R_L=\infty$, pin5=H, pin6=L | – | 0.85 | 1.5 | mA |
| Zener current 2 | I_{Z2} | $R_L=\infty$, pin5=L, pin6=H | – | 0.85 | 1.5 | mA |
| Output voltage 1 | V_{O1} | $R_L=60\Omega$, pin5=H, pin6=L | 6.6 | 7.2 | – | V |
| Output voltage 2 | V_{O2} | $R_L=60\Omega$, pin5=L, pin6=H | 6.6 | 7.1 | – | V |
| Saturation voltage (Pin10-1) | V_{CE10-1} | $R_L=R_C=\infty$, pin5=H, pin6=L, $I_{SINK}=100\text{mA}$ | – | 0.83 | 1.5 | V |
| Saturation voltage (Pin2-1) | V_{CE2-1} | $R_L=R_C=\infty$, pin5=L, pin6=H, $I_{SINK}=100\text{mA}$ | – | 0.83 | 1.5 | V |
| Saturation voltage (Pin8-2) | V_{CE8-2} | $R_L=R_C=\infty$, pin5=H, pin6=L, $I_{SOURCE}=100\text{mA}$ | – | 0.83 | 1.5 | V |
| Saturation voltage (Pin8-10) | V_{CE8-10} | $R_L=R_C=\infty$, pin5=L, pin6=H, $I_{SOURCE}=100\text{mA}$ | – | 0.83 | 1.5 | V |

APPLICATION INFORMATIONS

1. FORWARD AND REVERSE CONTROL LOGIC

| Pin #5 | Pin #6 | Pin #2 | Pin #10 | Function |
|------------|------------|--------|---------|----------|
| L (0.7V ↓) | L (0.7V ↓) | L | L | Brake |
| L (0.7V ↓) | H (2.0V ↑) | L | H | Reverse |
| H (2.0V ↑) | L (0.7V ↓) | H | L | Forward |
| H (2.0V ↑) | H (2.0V ↑) | H | H | Brake |

- If pin #5=H, pin #6=L, load current flows from pin #2 to pin #10 through a motor.
- If pin #5=L, pin #6=H, load current flows from pin #10 to pin #2 through a motor.
- If pin #5=pin #6=L or pin #5=pin #6=H, the KA8301 stops supplying the power to motor while absorbing counter EMF from the motor as a brake.

2. RUSH CURRENT ABSORBING CIRCUIT

If a high voltage generated during reversing operation is applied across pin #2 and pin #10, an internal comparator activates the rush current absorbing circuit.

3. DRIVE STAGE

In the forward mode, the drive stage supplies a load current to the motor from pin #2 to pin #10.
In the reverse mode, it supplies the current from pin #10 to pin #2.

The output voltage (V_{OUT}) applied to the motor is given by the followings;

$$V_{OUT} = V_{ZD} - V_{CE(sat)}, \text{ where } V_{ZD}: \text{ a zener voltage applied to pin \#4}$$

If pin #4 is left open, the output voltage is given by the followings;

$$V_{OUT} = V_{CC1} - V_{CE(sat, pnp)} - 2V_F - V_{CE(sat)}$$

CHARACTERISTIC GRAPHS

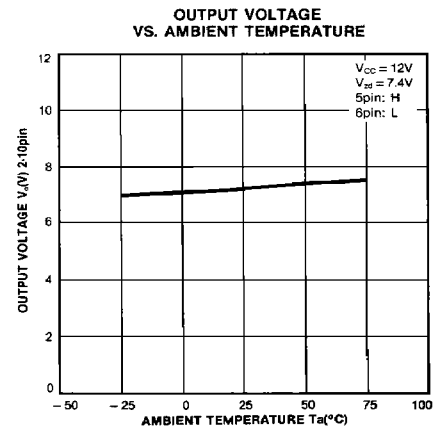
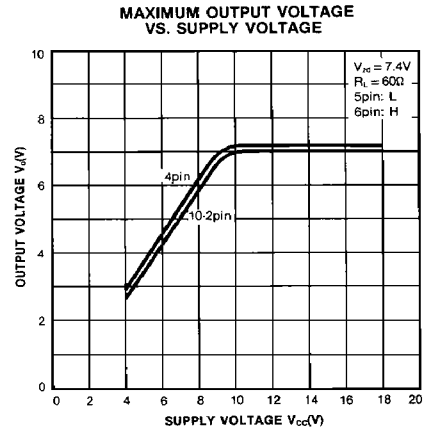
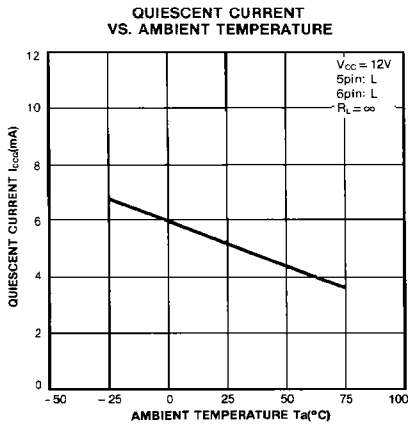
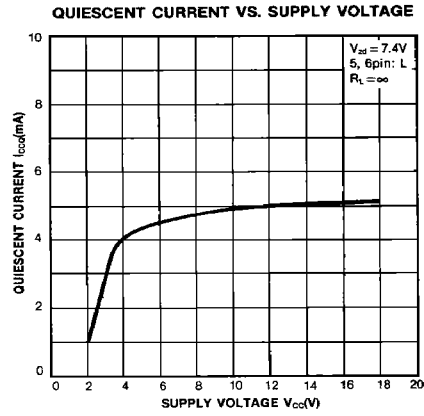
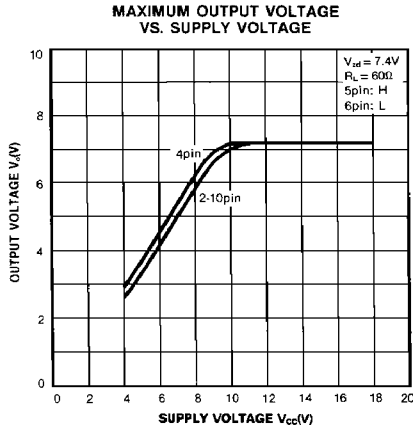

CHARACTERISTIC GRAPHS (Continued)

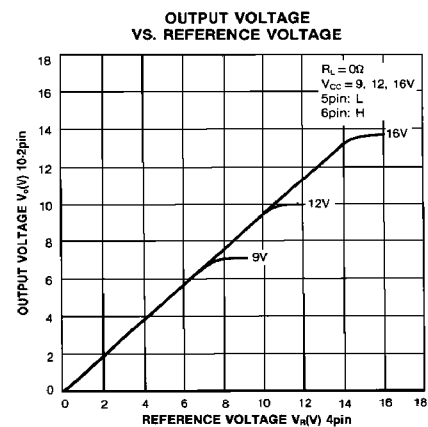
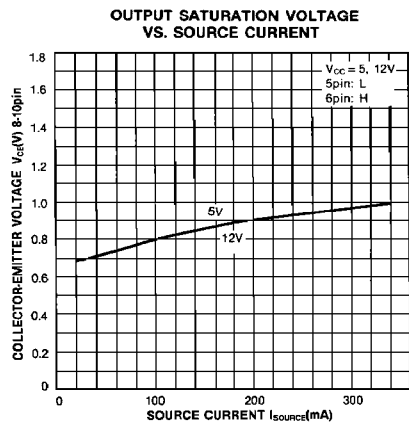
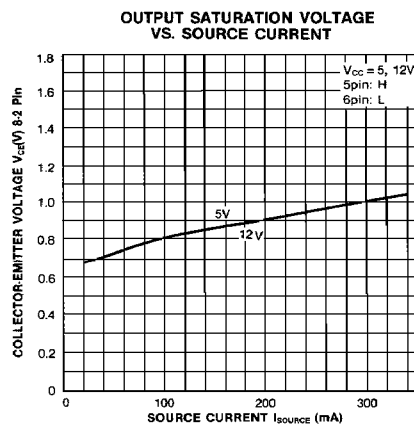
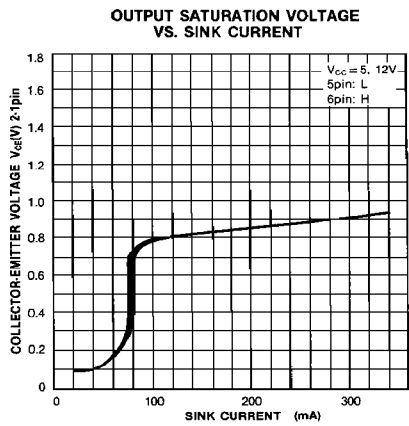
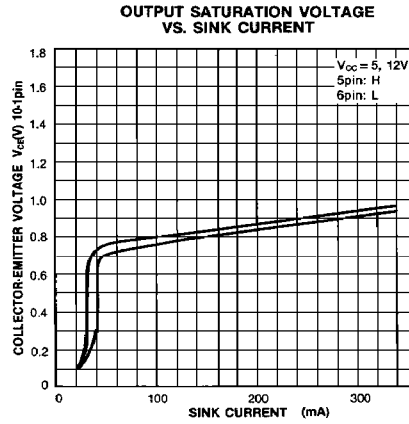
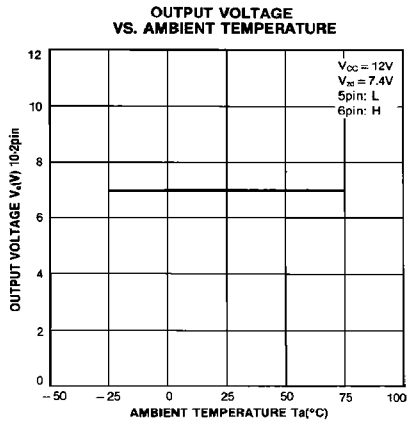

CHARACTERISTIC GRAPHS (Continued)

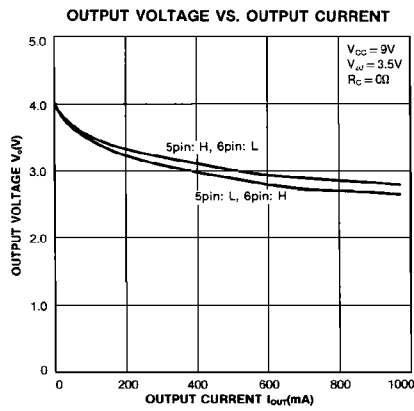
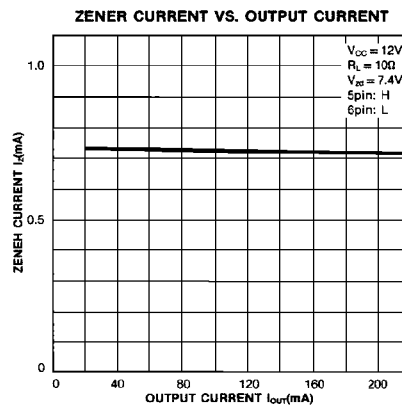
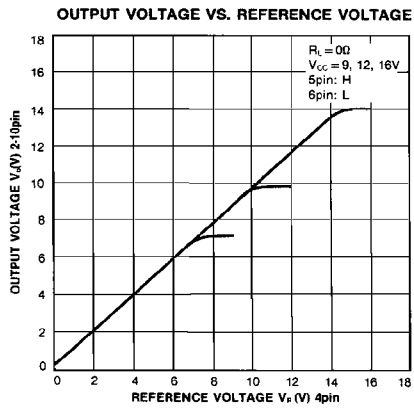

TEST CIRCUIT

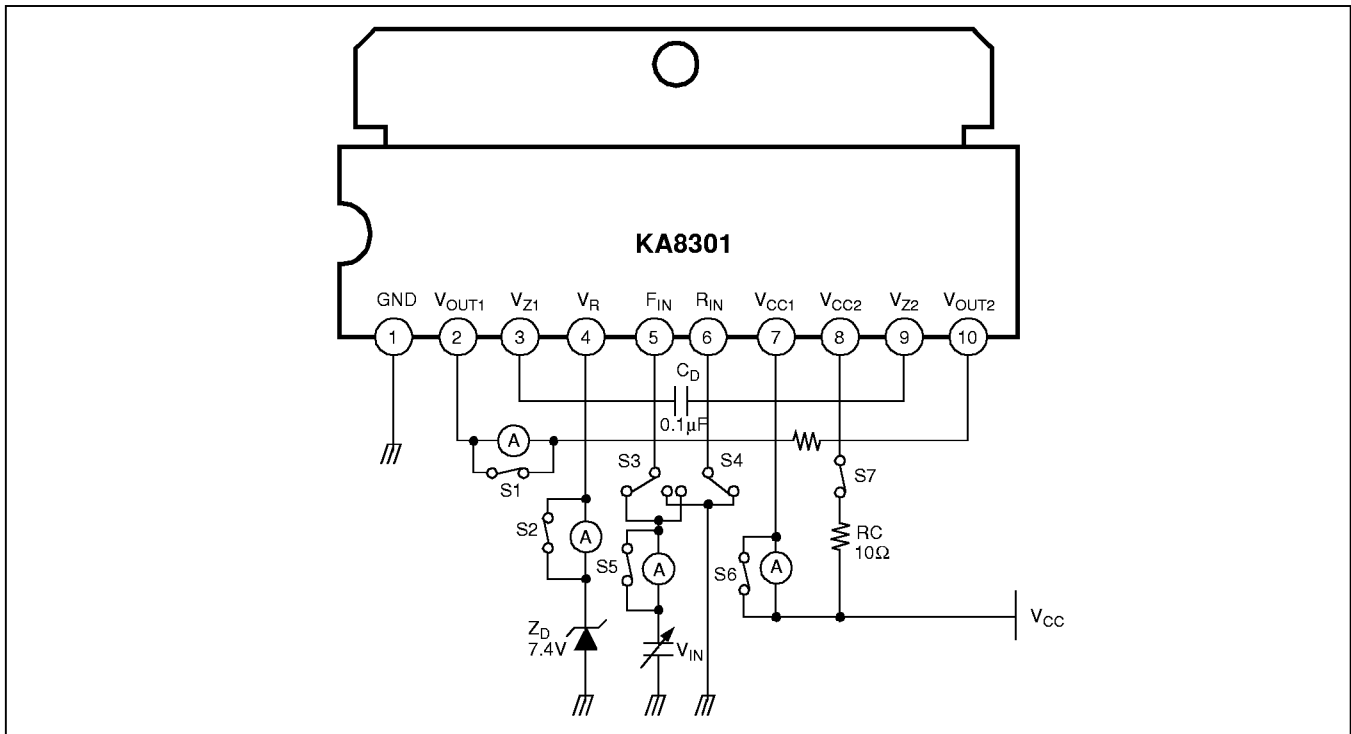

APPLICATION CIRCUIT

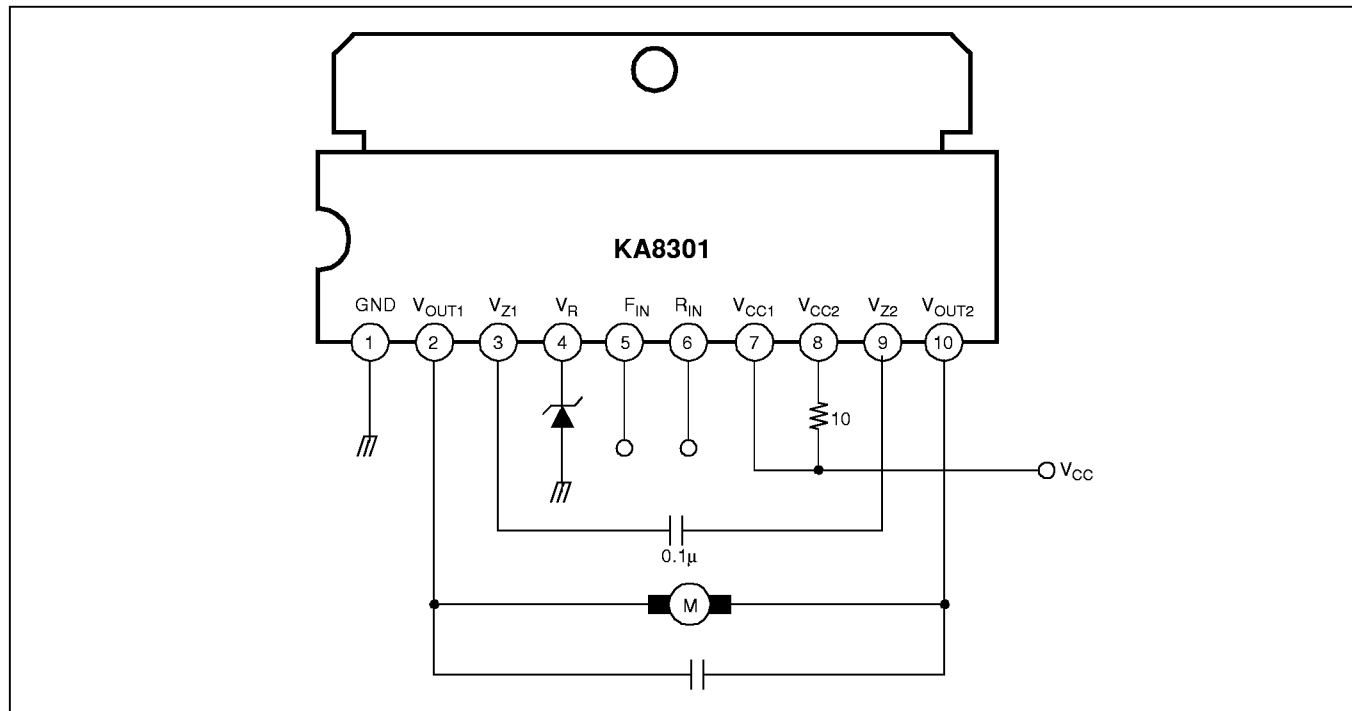

TRADEMARKS

The following are registered and unregistered trademarks Fairchild Semiconductor owns or is authorized to use and is not intended to be an exhaustive list of all such trademarks.

| | |
|----------------------|---------------|
| ACEx™ | ISOPLANAR™ |
| CoolFET™ | MICROWIRE™ |
| CROSSVOLT™ | POP™ |
| E ² CMOS™ | PowerTrench™ |
| FACT™ | QS™ |
| FACT Quiet Series™ | Quiet Series™ |
| FAST® | SuperSOT™-3 |
| FASTr™ | SuperSOT™-6 |
| GTO™ | SuperSOT™-8 |
| HiSeC™ | TinyLogic™ |

DISCLAIMER

FAIRCHILD SEMICONDUCTOR RESERVES THE RIGHT TO MAKE CHANGES WITHOUT FURTHER NOTICE TO ANY PRODUCTS HEREIN TO IMPROVE RELIABILITY, FUNCTION OR DESIGN. FAIRCHILD DOES NOT ASSUME ANY LIABILITY ARISING OUT OF THE APPLICATION OR USE OF ANY PRODUCT OR CIRCUIT DESCRIBED HEREIN; NEITHER DOES IT CONVEY ANY LICENSE UNDER ITS PATENT RIGHTS, NOR THE RIGHTS OF OTHERS.

LIFE SUPPORT POLICY

FAIRCHILD'S PRODUCTS ARE NOT AUTHORIZED FOR USE AS CRITICAL COMPONENTS IN LIFE SUPPORT DEVICES OR SYSTEMS WITHOUT THE EXPRESS WRITTEN APPROVAL OF FAIRCHILD SEMICONDUCTOR CORPORATION. As used herein:

1. Life support devices or systems are devices or systems which, (a) are intended for surgical implant into the body, or (b) support or sustain life, or (c) whose failure to perform when properly used in accordance with instructions for use provided in the labeling, can be reasonably expected to result in significant injury to the user.
2. A critical component is any component of a life support device or system whose failure to perform can be reasonably expected to cause the failure of the life support device or system, or to affect its safety or effectiveness.

PRODUCT STATUS DEFINITIONS

Definition of Terms

| Datasheet Identification | Product Status | Definition |
|--------------------------|------------------------|---|
| Advance Information | Formative or In Design | This datasheet contains the design specifications for product development. Specifications may change in any manner without notice. |
| Preliminary | First Production | This datasheet contains preliminary data, and supplementary data will be published at a later date. Fairchild Semiconductor reserves the right to make changes at any time without notice in order to improve design. |
| No Identification Needed | Full Production | This datasheet contains final specifications. Fairchild Semiconductor reserves the right to make changes at any time without notice in order to improve design. |
| Obsolete | Not In Production | This datasheet contains specifications on a product that has been discontinued by Fairchild semiconductor. The datasheet is printed for reference information only. |