

### 4-CH MOTOR DRIVER

The KA9258D is a monolithic integrated circuit, and suitable for 4-CH motor driver which drives tracking actuator, focus actuator, sled motor and loading motor of CD/CD-ROM/DVD system, and can also drive spindle motor of CD system.

### FEATURES

- 1-phase, full-wave, linear DC motor driver
- Output gain adjustable
- Built in OP-amp
- Built in mute function
- Built in level shift circuit
- Built in thermal shutdown function
- Operating range 6~13.2V

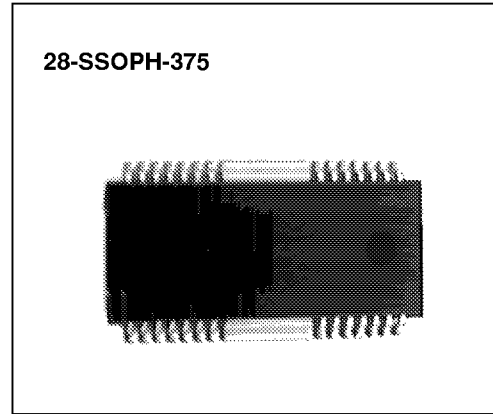

### ORDERING INFORMATION

Device	Package	Operating Temperature
KA9258D	28-SSOPH-375	-40°C ~ +85°C

### TARGET APPLICATION

- CD-PLAYER
- VIDEO-CD
- CAR-CD

### BLOCK DIAGRAM

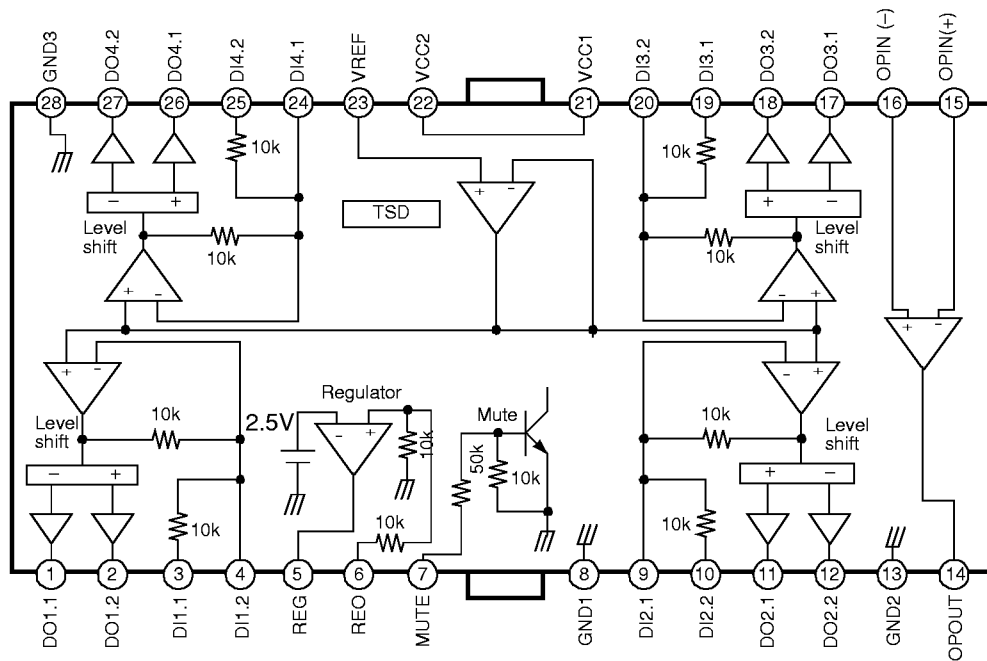

## PIN CONFIGURATION

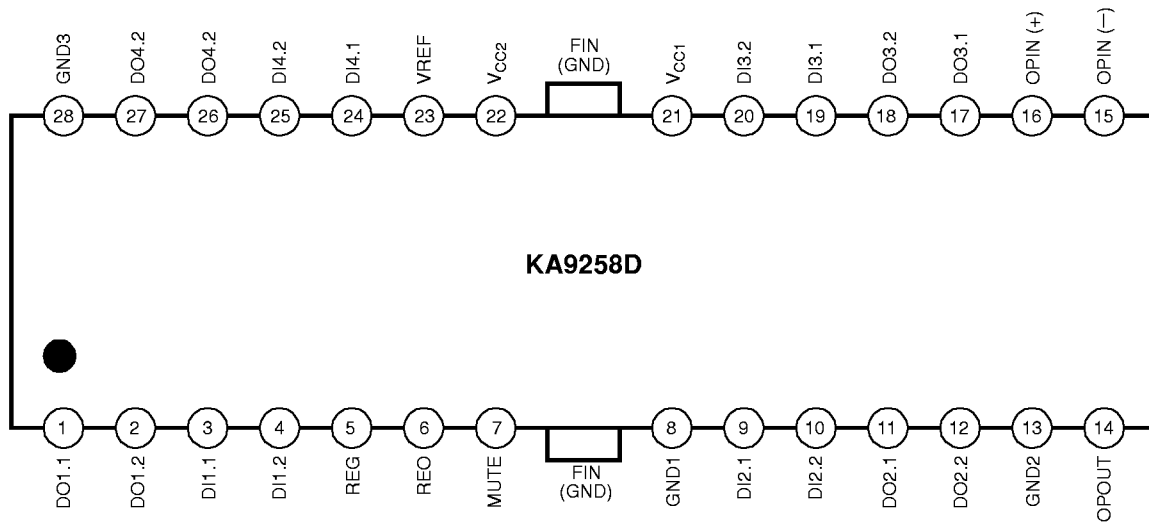

## PIN DESCRIPTION

Pin No.	Symbol	I/O	Description	Pin No.	Symbol	I/O	Description
1	DO1.1	O	Drive output	15	OPIN(-)	I	Op-amp input (-)
2	DO1.2	O	Drive output	16	OPIN(+)	I	Op-amp input (+)
3	DI1.1	I	Drive input	17	DO3.1	O	Drive output
4	DI1.2	I	Drive input	18	DO3.2	O	Drive output
5	REG	-	Regulator	19	DI3.1	I	Drive input
6	REO	O	Regulator output	20	DI3.2	I	Drive input
7	MUTE	I	Mute	21	V <sub>CC1</sub>	-	Supply voltage
8	GND1	-	Ground 1	22	V <sub>CC2</sub>	-	Supply voltage
9	DI2.1	I	Drive input	23	VREF	I	2.5V bias voltage
10	DI2.2	I	Drive input	24	DI4.1	I	Drive input
11	DO2.1	O	Drive output	25	DI4.2	I	Drive input
12	DO2.2	O	Drive output	26	DO4.1	O	Drive output
13	GND2	-	Ground 2	27	DO4.2	O	Drive output
14	OPOUT	O	Op-amp output	28	GND3	-	Ground 3

EQUIVALENT CIRCUITS

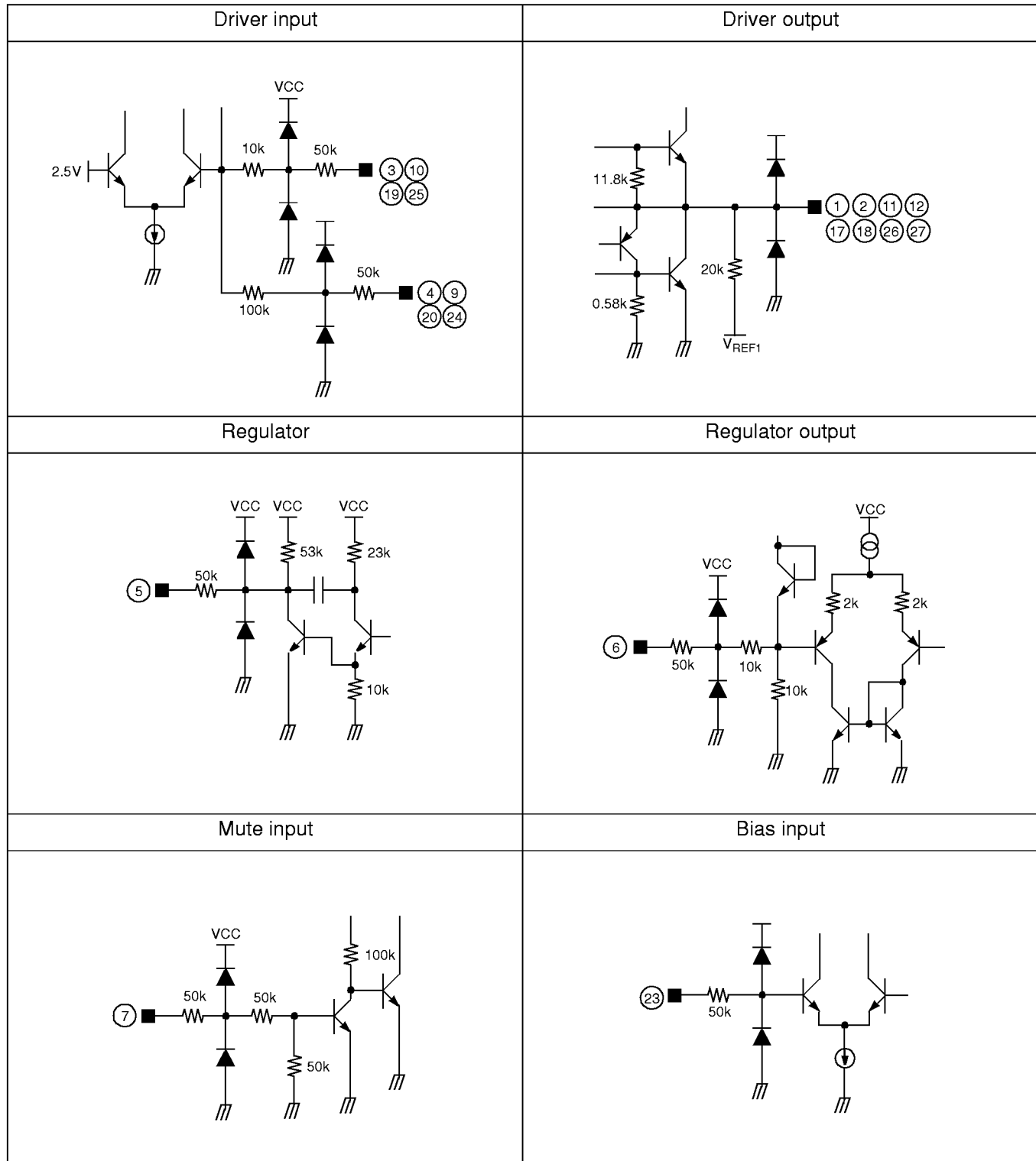

**EQUIVALENT CIRCUITS**

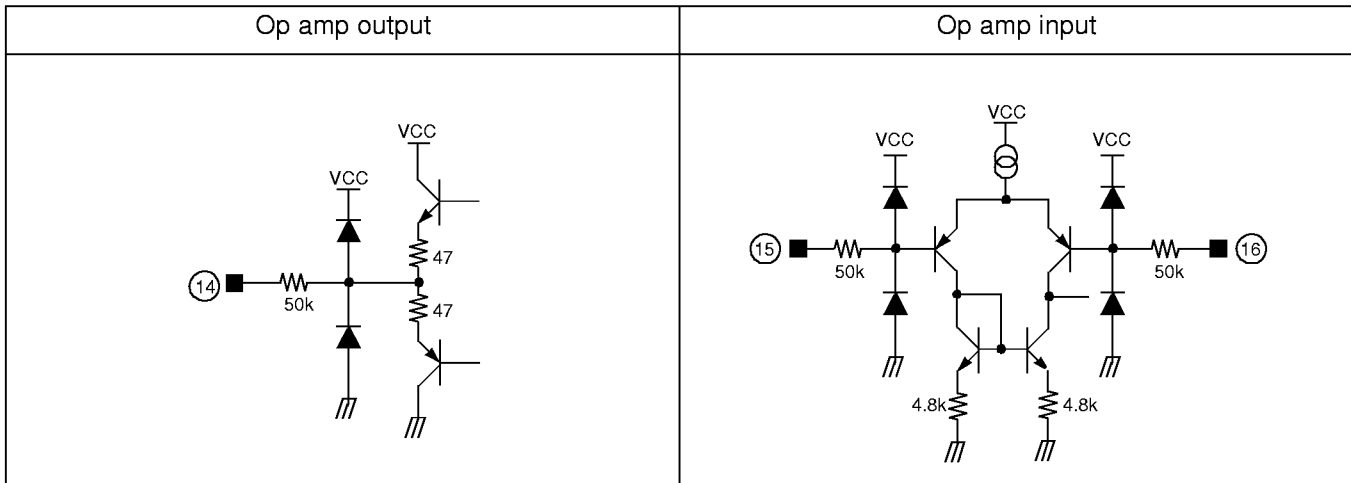

**ABSOLUTE MAXIMUM RATING (Ta=25°C)**

Characteristics	Symbol	Value	Unit
Supply voltage	$V_{CC}$	18	V
Power dissipation	$P_D$	1.7 <sup>note</sup>	W
Operating temperature	$T_{OPR}$	-40 ~ +85	°C
Storage temperature	$T_{STG}$	-55 ~ +150	°C
Maximum output current	$I_{OMAX}$	1	A

**NOTE:@**

1. When mounted on 76.2mm × 114mm × 1.57mm PCB (Phenolic resin material).
2. Power dissipation reduces 13.6mW / °C for using above Ta=25°C
3. Do not exceed Pd and SOA.

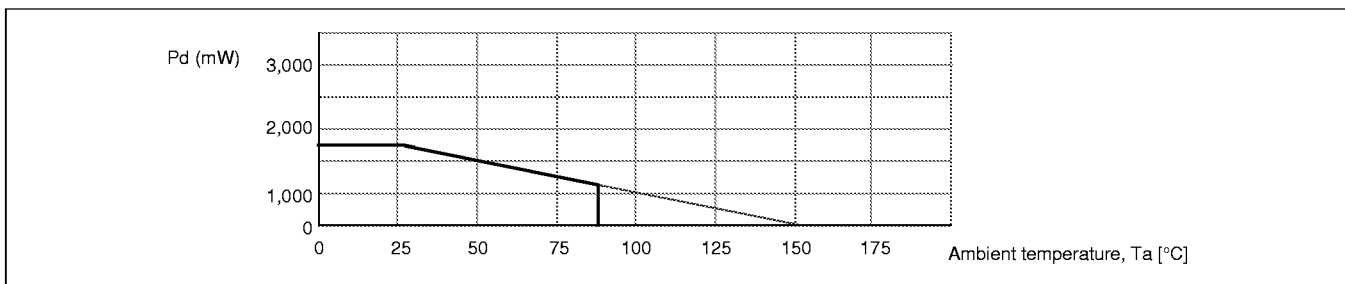

**RECOMMENDED OPERATING CONDITION (Ta=25°C)**

Characteristics	Symbol	Value	Unit
Operating supply voltage	V <sub>OPR</sub>	6 ~ 13.2	V

**ELECTRICAL CHARACTERISTICS (Ta=25°C, V<sub>CC</sub>=8V, unless otherwise specified)****A. REGULATOR PART**

Characteristic	Symbol	Test conditions	Min.	Typ.	Max.	Unit
Regulator output voltage	V <sub>REG</sub>	I <sub>L</sub> =100mA	4.75	5	5.25	V
Load regulation	ΔV <sub>RL</sub>	I <sub>L</sub> =0 ~ 200mA	-40.0	0	10.0	mV
Line regulation	ΔV <sub>CC</sub>	I <sub>L</sub> =200mA, V <sub>CC</sub> =6 ~ 9V	-10.0	0	20.0	mV

**B. DRIVE PART**

Characteristic	Symbol	Test conditions	Min.	Typ.	Max.	Unit
Quiescent circuit current	I <sub>CCQ</sub>	V <sub>I</sub> =0	5.5	9.5	13.5	mA
Input bias current	I <sub>BOP</sub>	V <sub>I</sub> =0	-	-	300	nA
Input offset voltage	V <sub>OFOP</sub>	-	-5.0	0	5.0	mV
Output offset voltage	V <sub>OO</sub>	-	-30	0	30	
Maximum sink current	I <sub>SINK</sub>	R <sub>L</sub> =4Ω, V <sub>CC</sub>	0.5	0.8	-	A
Maximum source current	I <sub>SOURCE</sub>	R <sub>L</sub> =4Ω, GND	0.5	0.8	-	
Maximum output voltage	V <sub>OM</sub>	V <sub>I</sub> =2V <sub>RMS</sub> , 1kHz	2.5	3.0	-	V
Closed loop voltage gain	A <sub>VF</sub>	V <sub>I</sub> =0.1V <sub>RMS</sub> , 1kHz	4.5	6.5	7.5	dB
Ripple rejection ratio	RR	V <sub>I</sub> =-20dB, 120Hz	60.0	80.0	-	
Slew rate	SR	100Hz, Square wave	1.0	2.0	-	V / μs

**C. OP AMP PART**

Characteristic	Symbol	Test conditions	Min.	Typ.	Max.	Unit
Input offset voltage	V <sub>OF1</sub>	-	-5	-	+5	mV
Input bias current	I <sub>B1</sub>	-	-	-	300	nA
High level output voltage	V <sub>OH1</sub>	-	6	-	-	V
Low level output voltage	V <sub>OL1</sub>	-	-	-	1.8	V
Output sink current	I <sub>SINK1</sub>	R <sub>L</sub> =50Ω, GND	10	40	-	mA
Output source current	I <sub>SOURCE1</sub>	R <sub>L</sub> =50Ω, V <sub>CC</sub>	10	50	-	mA
Open loop voltage gain	G <sub>VO1</sub>	V <sub>IN</sub> =-75dB, f=1kHz	65	78	-	dB
Ripple rejection ratio	RR1	V <sub>IN</sub> =-20dB, f=120kHz	50	70	-	dB
Slew Rate	SR1	Square, V <sub>OUT</sub> =2Vp-p, f=120kHz	0.5	1	-	V / μs
Common mode rejection ratio	CMRR1	V <sub>IN</sub> =-20dB, f=1kHz	70	84	-	dB

APPLICATION INFORMATION

1. MUTE

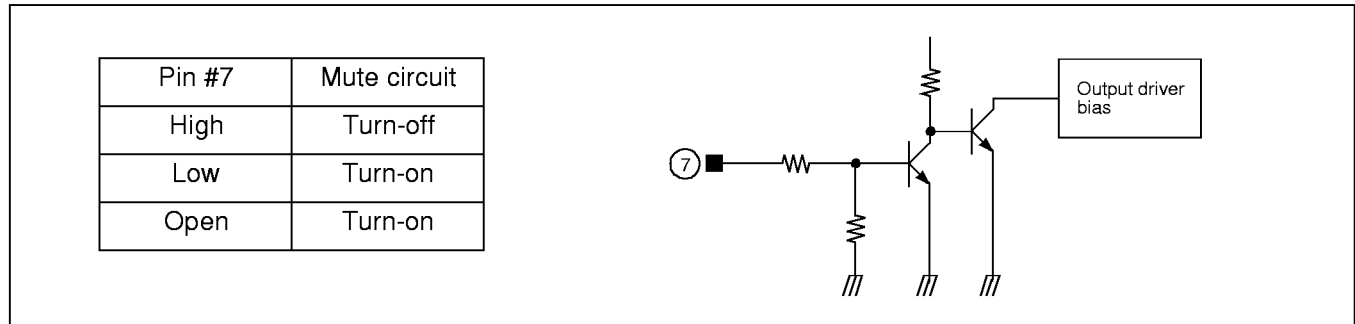

- When the mute pin #7 is open or the voltage of the mute pin #7 is below 0.5V, the mute circuit is activated so that the output circuit will be muted.
- When the voltage of the mute pin is above 2V, the mute circuit is stopped and the output circuit is operated normally.
- If the chip temperature rises above 175°C, then the TSD (Thermal Shutdown) circuit is activated and the output circuit is muted.

2. TSD (THERMAL SHUTDOWN)

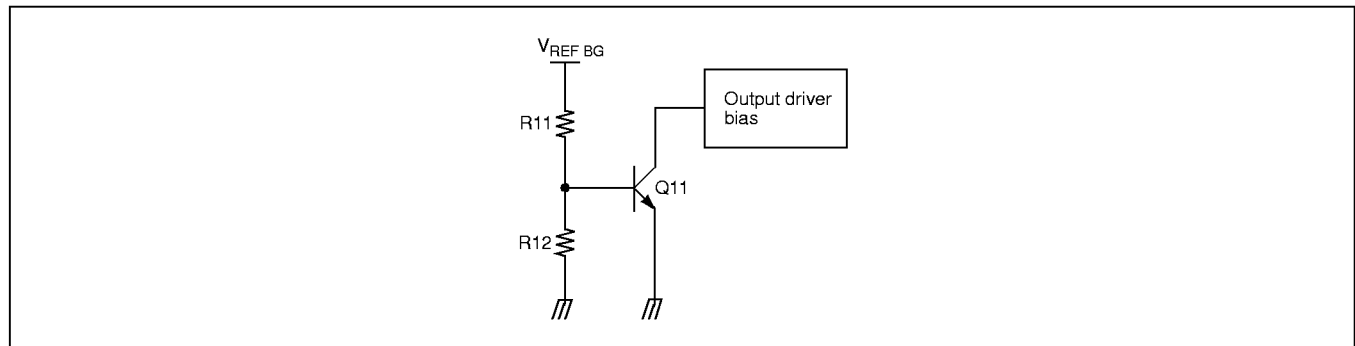

- The  $V_{REF\ BG}$  is the output voltage of the band-gap-referenced biasing circuit and acts as the input voltage of the TSD circuit.
- The base-emitter voltage of the TR, Q11 is designed to turn-on at below voltage.  

$$V_{BE} = V_{REF\ BG} \times R12 / (R11 + R12) = 460mV$$
- When the chip temperature rises up to 175°C, then the turn-on voltage of the Q11 would drop down to 460mV. (Hysteresis: 25°C)  
 Hence, the Q11 would turn on so the output circuit will be muted.

### 3. OP-AMP

OP-amp is integrated in the IC for user's convenience.

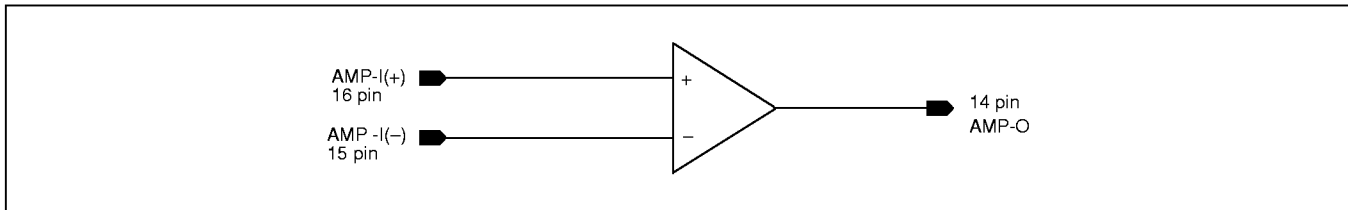

### 4. DRIVER

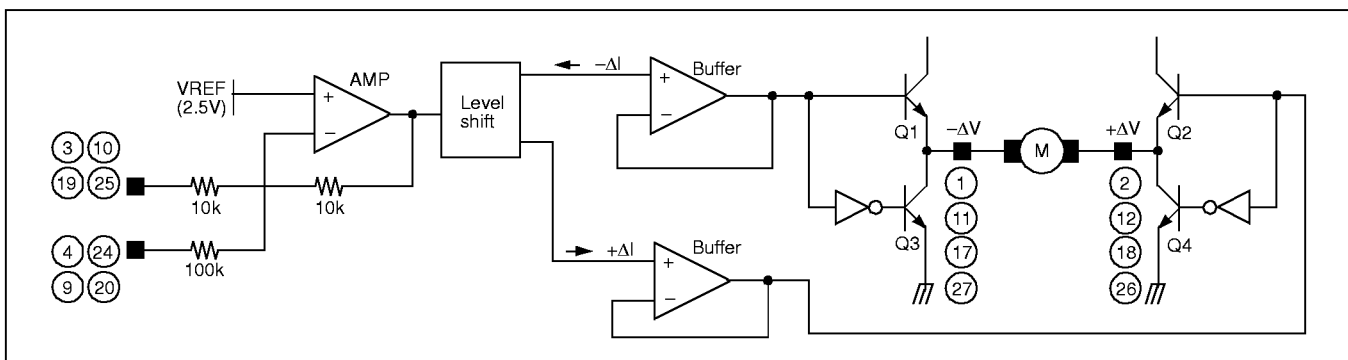

- The voltage,  $V_{REF}$ , is the reference voltage given by the bias voltage of the pin #23.
- The input signal through the pin #3 is amplified by 10k/10k times and then fed to the level shift.
- The level shift produces the current due to the difference between the input signal and the arbitrary reference signal. The current produced as  $+\Delta I$  and  $-\Delta I$  is fed into the driver buffer.
- Driver Buffer operates the power TR of the output stage according to the state of the input signal.
- The output stage is the BTL driver and the motor is rotating in forward direction by operating TR Q1 and TR Q4. On the other hand, if TR Q2 and TR Q3 is operating, the motor is rotating in reverse direction
- When the input voltage through the pin #3 is below the  $V_{REF}$ , then the direction of the motor in forward direction.
- When the input voltage through the pin #3 is above the  $V_{REF}$ , then the direction of the motor in reverse direction.
- If it is desired to change the gain, then the pin #4 or #24 can be used.



5. Connect a by-pass capacitor, 0.1 $\mu$ F between the supply voltage source.

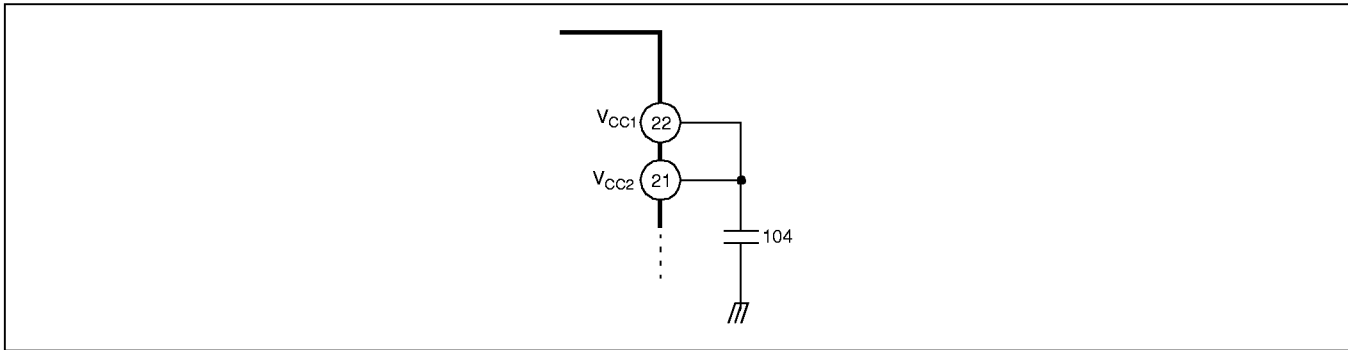

6. Radiation fin is connecting to the internal GND of the package.  
Connect the fin to the external GND.

ELECTIRICAL CHARACTERISTICS CURVES

Vcc vs. Icc

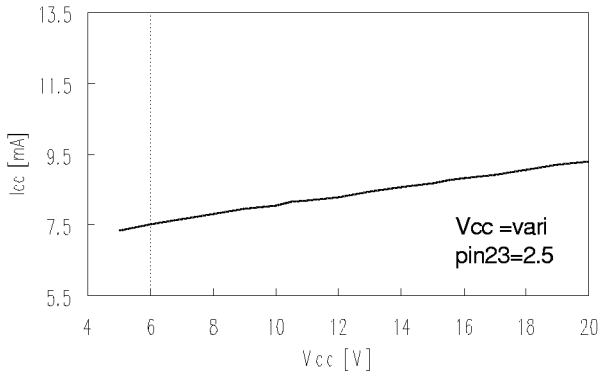

Vcc vs. Imute

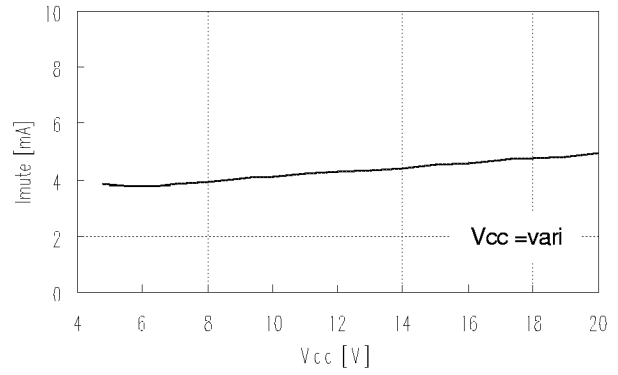

Vcc vs. Vreg

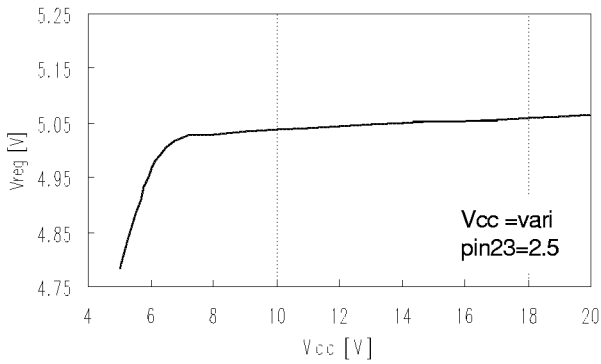

Vcc vs. Isink

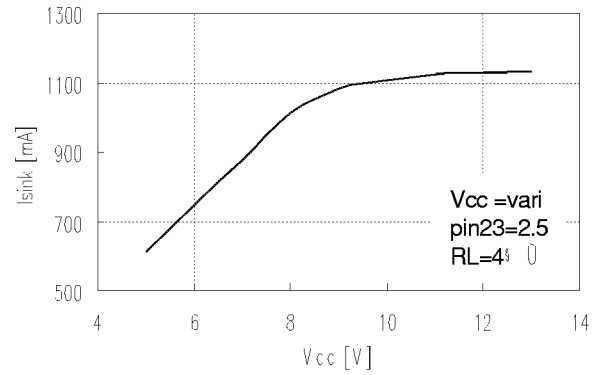

Vcc vs. Isource

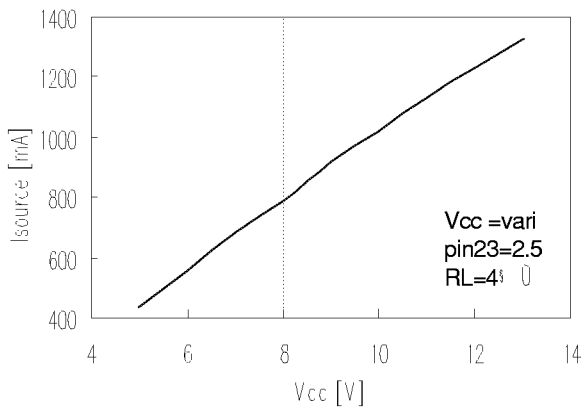

Vcc vs. Avf

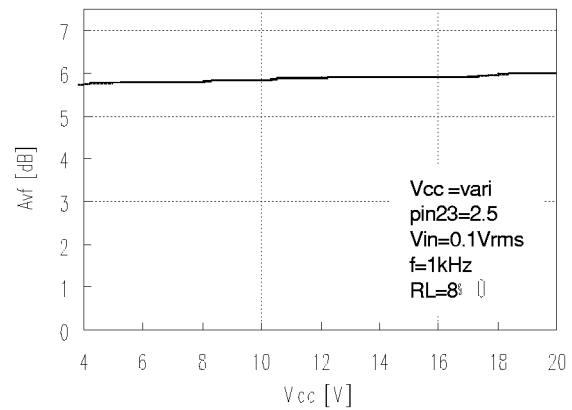

ELECTIRICAL CHARACTERISTICS CURVES (Continued)

Temp vs.  $I_{CC}$

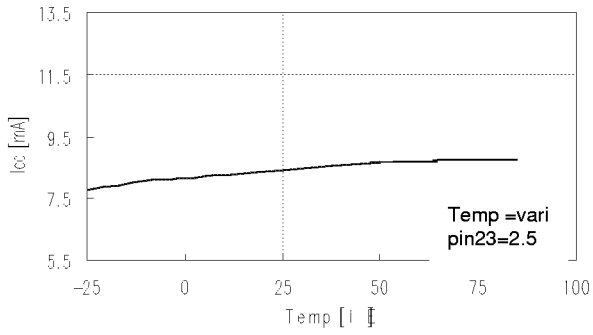

Temp vs.  $I_{CCM}$

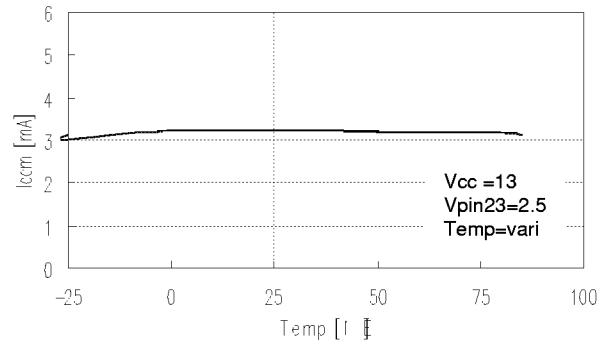

Temp vs.  $V_{REG}$

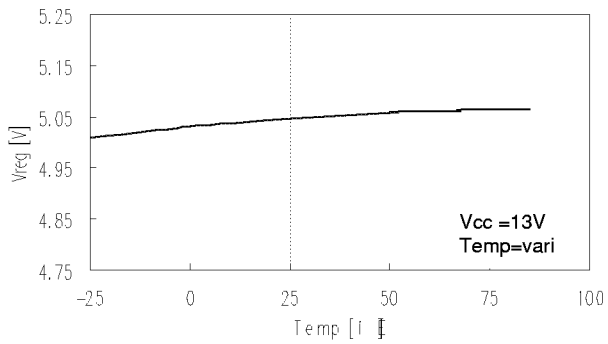

Temp vs.  $I_{SOURCE}$

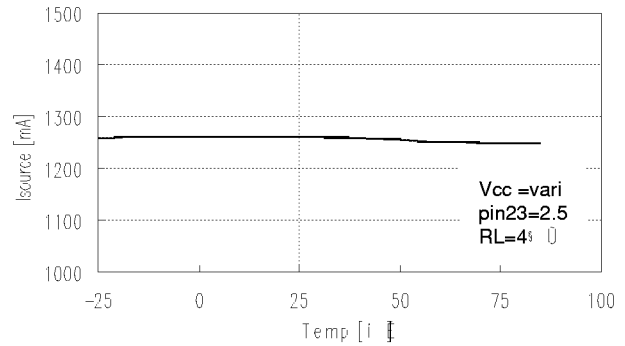

Temp vs.  $I_{SINK}$

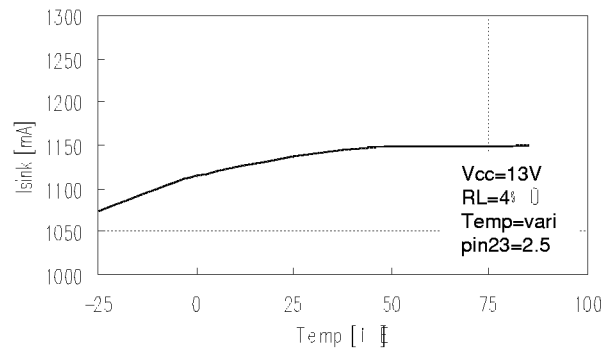

TEST CIRCUIT

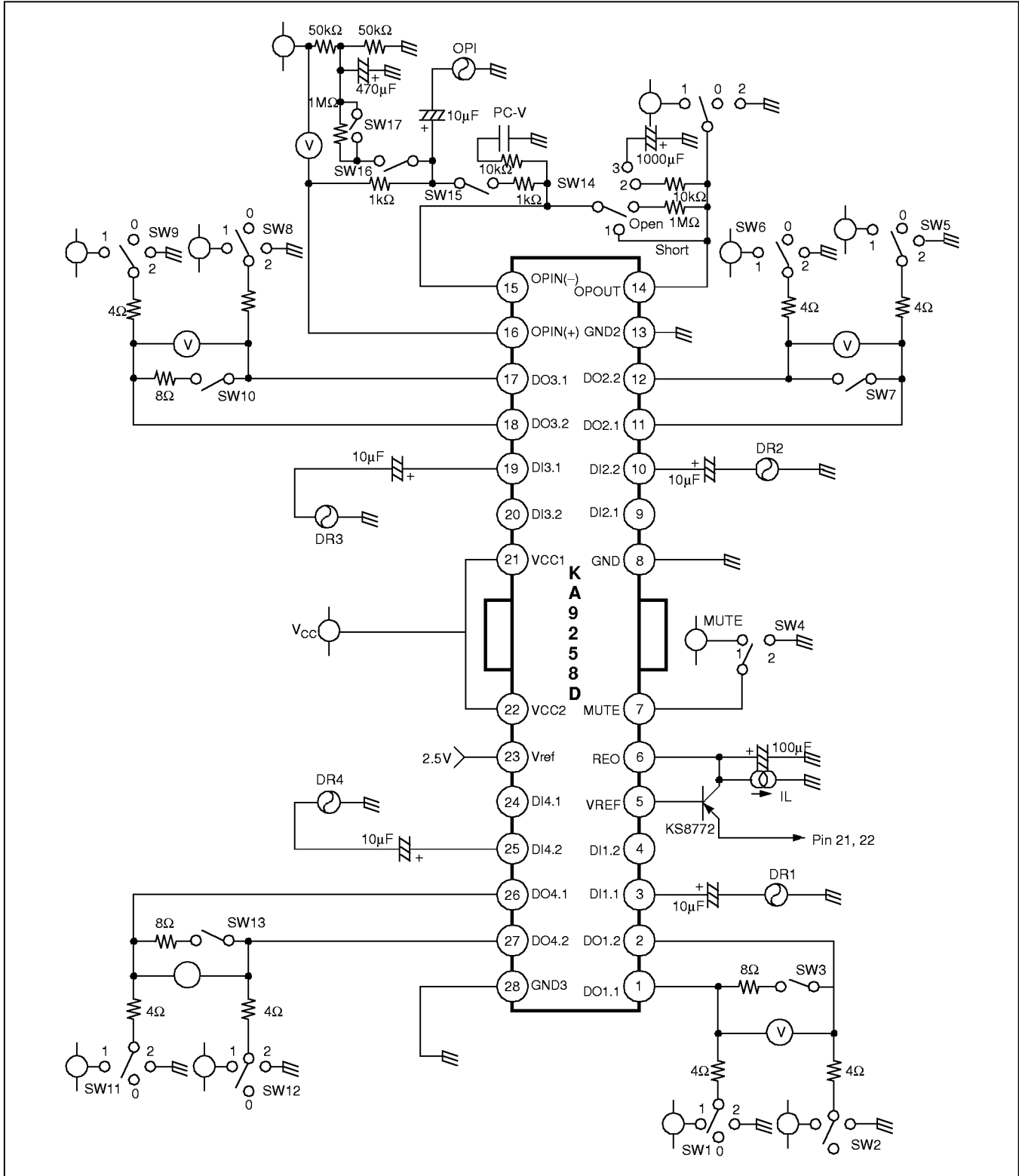

APPLICATION CIRCUIT

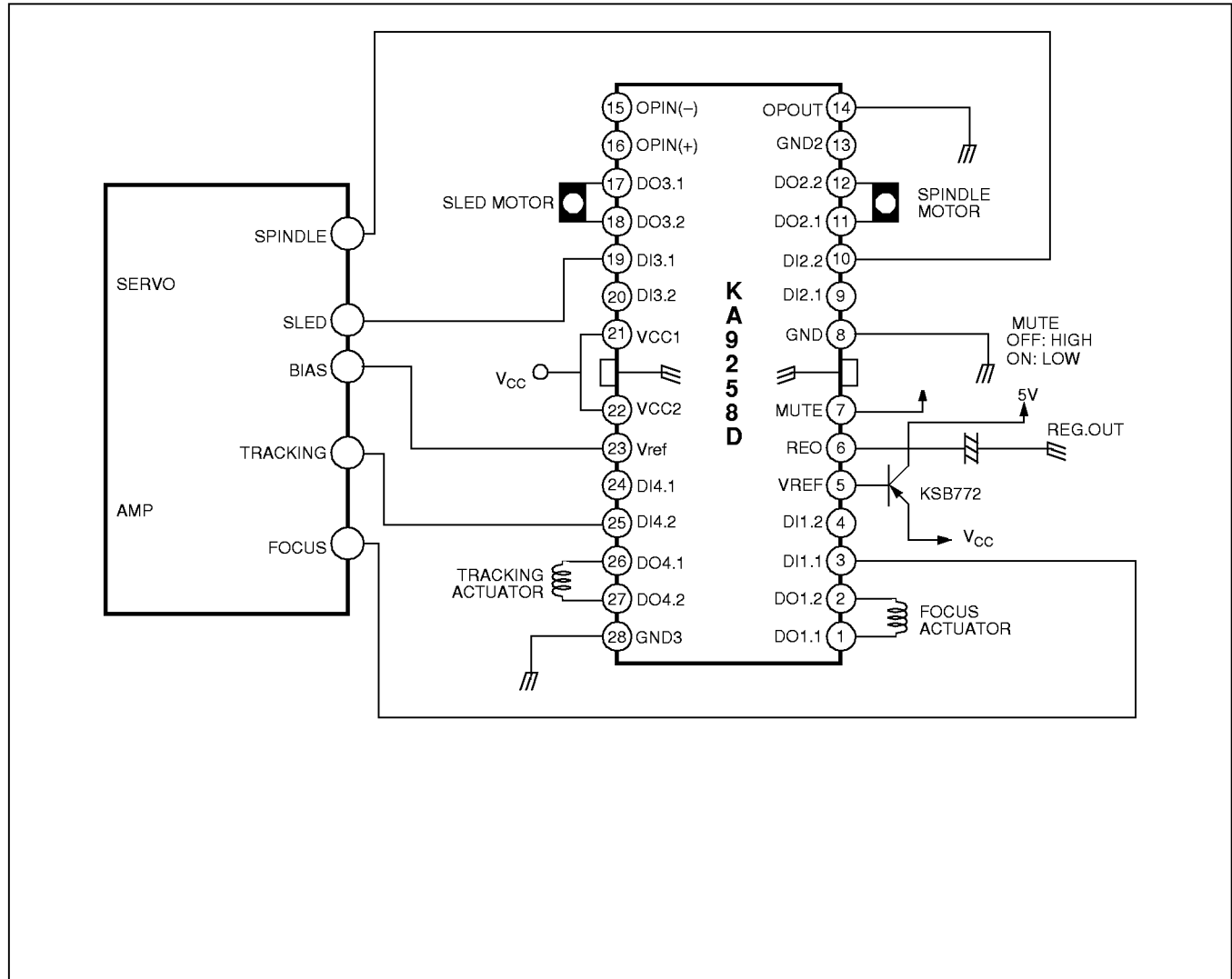

THERMAL SHUT DOWN CIRCUIT

The IC is broken down by the heat when overload condition continue for a long time. So KA9258D have thermal shut down circuit to prevent this case. At that time the temperature of IC rise over 175°C, the circuit is operating and protect the IC against breakdown.

## TRADEMARKS

The following are registered and unregistered trademarks Fairchild Semiconductor owns or is authorized to use and is not intended to be an exhaustive list of all such trademarks.

ACE <sup>x</sup> ™	ISOPLANAR™
CoolFET™	MICROWIRE™
CROSSVOLT™	POP™
E <sup>2</sup> CMOS™	PowerTrench™
FACT™	QS™
FACT Quiet Series™	Quiet Series™
FAST®	SuperSOT™-3
FAST <sub>r</sub> ™	SuperSOT™-6
GTO™	SuperSOT™-8
HiSeC™	TinyLogic™

## DISCLAIMER

FAIRCHILD SEMICONDUCTOR RESERVES THE RIGHT TO MAKE CHANGES WITHOUT FURTHER NOTICE TO ANY PRODUCTS HEREIN TO IMPROVE RELIABILITY, FUNCTION OR DESIGN. FAIRCHILD DOES NOT ASSUME ANY LIABILITY ARISING OUT OF THE APPLICATION OR USE OF ANY PRODUCT OR CIRCUIT DESCRIBED HEREIN; NEITHER DOES IT CONVEY ANY LICENSE UNDER ITS PATENT RIGHTS, NOR THE RIGHTS OF OTHERS.

## LIFE SUPPORT POLICY

FAIRCHILD'S PRODUCTS ARE NOT AUTHORIZED FOR USE AS CRITICAL COMPONENTS IN LIFE SUPPORT DEVICES OR SYSTEMS WITHOUT THE EXPRESS WRITTEN APPROVAL OF FAIRCHILD SEMICONDUCTOR CORPORATION. As used herein:

1. Life support devices or systems are devices or systems which, (a) are intended for surgical implant into the body, or (b) support or sustain life, or (c) whose failure to perform when properly used in accordance with instructions for use provided in the labeling, can be reasonably expected to result in significant injury to the user.
2. A critical component is any component of a life support device or system whose failure to perform can be reasonably expected to cause the failure of the life support device or system, or to affect its safety or effectiveness.

## PRODUCT STATUS DEFINITIONS

### Definition of Terms

Datasheet Identification	Product Status	Definition
Advance Information	Formative or In Design	This datasheet contains the design specifications for product development. Specifications may change in any manner without notice.
Preliminary	First Production	This datasheet contains preliminary data, and supplementary data will be published at a later date. Fairchild Semiconductor reserves the right to make changes at any time without notice in order to improve design.
No Identification Needed	Full Production	This datasheet contains final specifications. Fairchild Semiconductor reserves the right to make changes at any time without notice in order to improve design.
Obsolete	Not In Production	This datasheet contains specifications on a product that has been discontinued by Fairchild semiconductor. The datasheet is printed for reference information only.