



SANYO Semiconductors

DATA SHEET

LA7858

**Monolithic Linear IC
For Very High Resolution CRT
Display Synchronization**
Overview

The LA7858 is sync-deflection circuit IC dedicated to CRT display use. They can be connected to the LA7838 (for vertical output use) to form a sync-deflection circuit that meets every requirement for CRT display use.

The LA7858 is performance-improved versions of the existing LA7853. The LA7858 is intended for use in very high-definition display ($f_H = 64$ to 150kHz) applications. When the horizontal frequency exceeds approximately 64kHz, problems are experienced with horizontal jitter which has been less of a problem in low-frequency display applications. The newly developed LA7858, which are fabricated with a special production process, are capable of suppressing horizontal jitter components successfully (30% reduced as compared with our existing similar Type Nos.). The LA7858 is ideally suited for use in high performance-required applications.

The LA7858 is pin-compatible with the LA7853, respectively. The LA7858 is different in the vertical sync pull-in range (LA7858 : 20Hz).

Features

- The horizontal oscillation frequency can be adjusted stably from 15kHz to 150kHz.
- The horizontal display can be shifted right/left.
- The horizontal/vertical sync input can be used intact regardless of the difference in pulse polarity and pulse width.
- The AFC feedback sawtooth wave can be obtained by simply applying a flyback pulse to the IC as a trigger pulse.
- Any duty of the horizontal pulse can be set.
- The LA7858 can be connected to the LA7838 to develop pictures with the interlace characteristics, crossover distortion characteristics improved.

Functions

[Horizontal Block]

- Horizontal sync input
- Horizontal phase shift
- AFC sawtooth wave generator
- Horizontal pulse duty setting
- Horizontal OSC
- AFC
- X-ray protector

[Vertical Block]

- Vertical trigger input
- Vertical OSC
- Vertical sawtooth wave generator
- Sampling type DC voltage control

■ Any and all SANYO Semiconductor Co.,Ltd. products described or contained herein are, with regard to "standard application" intended for the use as general electronics equipment (home appliances, AV equipment, communication device, office equipment, industrial equipment etc.). The products mentioned herein shall not be intended for use for any "special application" (medical equipment whose purpose is to sustain life, aerospace instrument, nuclear control device, burning appliances, transportation machine, traffic signal system, safety equipment, etc.) that shall require extremely high level of reliability and can directly threaten human lives in case of failure or malfunction of the product or may cause harm to human bodies, nor shall they grant any guarantee thereof. If you should intend to use our products for applications outside the standard applications of our customer who is considering such use and/or outside the scope of our intended standard applications, please consult with us prior to the intended use. If there is no consultation or inquiry before the intended use, our customer shall be solely responsible for the use.

■ Specifications of any and all SANYO Semiconductor Co.,Ltd. products described or contained herein stipulate the performance, characteristics, and functions of the described products in the independent state, and are not guarantees of the performance, characteristics, and functions of the described products as mounted in the customer's products or equipment. To verify symptoms and states that cannot be evaluated in an independent device, the customer should always evaluate and test devices mounted in the customer's products or equipment.

SANYO Semiconductor Co., Ltd.

TOKYO OFFICE Tokyo Bldg., 1-10, 1 Chome, Ueno, Taito-ku, TOKYO, 110-8534 JAPAN

Specifications

Maximum Ratings at Ta = 25°C

Parameter	Symbol	Conditions	Ratings	Unit
Maximum Supply Voltage	V ₁₁ , V ₂₂ max		14	V
Allowable Power Dissipation	Pd max	Ta ≤ 65°C	780	mW
Operating Temperature	Topr		-20 to +85	°C
Storage Temperature	Tstg		-55 to +125	°C

Operating Conditions at Ta = 25°C

Parameter	Symbol	Conditions	Ratings	Unit
Recommended Supply Voltage	V ₁₁ , V ₂₂		12	V
Operating Voltage Range	V ₁₁ , V ₂₂ op		9 to 13.5	V
Recommended Vertical Pulse Input Peak Value	V _{pulse}		5	Vp-p
Operating Vertical Pulse Input Peak Value Range	V _{pulse}		2 to 6	Vp-p
Recommended Horizontal Pulse Input Peak Value	H _{pulse}		5	Vp-p
Operating Horizontal Pulse Input Peak Value Range	H _{pulse}		2 to 6	Vp-p

Electrical Characteristics at Ta = 25°C, V₁₁, V₂₂ = 12V

Parameter	Symbol	Conditions	Ratings			Unit
			min	typ	max	
V _{CC10} Current Dissipation	I ₁₁		12		30	mA
V _{CC20} Current Dissipation	I ₂₂		5		12	mA
Vertical Frequency Pull-in Range	V _{PIN}	Vertical sync 60Hz	21.0		23.0	Hz
Vertical Free-running Frequency	f _V	f _V center 55Hz	50		60	Hz
Increased/Reduced Voltage Characteristic of Vertical Frequency	Δf _{V,V}	V ₂₂ = 12±1V, 55Hz at 12V	-0.1		0.1	Hz
Midpoint Control Threshold Level			3.8		4.4	V
Vertical OSC Start Voltage	f _{V.st}				4.0	V
Temperature Characteristic of Vertical Frequency		Ta = -10 to +60°C	-0.028		0.028	Hz/°C
Vertical Driver Amplification Factor	G _V		12		18	dB
Horizontal AFC DC Loop Gain	I _{AFC}		±0.85		±1.6	mA
Horizontal Free-running Frequency	f _H	f _H center 15.734kHz	-750		750	Hz
Horizontal OSC Start Voltage	f _{H.st}				4.0	V
Increased/Reduced Voltage Characteristic of Horizontal Frequency	ΔH,V	V ₁₁ = 12±1V, 15.734kHz at 12V	-50		50	Hz
Horizontal OSC Warm-up Drift	Δf _H	5s. to 30min, after application of power	-50		50	Hz
Temperature Characteristic of Horizontal Frequency		Ta = -10 to +60°C	-2.9		2.9	Hz/°C
Horizontal Output Drive Current	I ₁₃		6.0		12.0	mA
Increased/Reduced Voltage Characteristic of Phase Shifter Delay Time		V ₁₁ = 12±1V	-0.5		0.5	%/V
Temperature Characteristic of Phase Shifter Delay Time		Ta = -10 to +60°C	-0.1		0.1	%/°C
Increased/Reduced Voltage Characteristic of Phase Shifter Pulse Width		V ₁₁ = 12±1V	-1.0		1.0	%/V
Temperature Characteristic of Phase Shifter Pulse Width		Ta = -10 to +60°C	-0.13		0.13	%/°C
AFC Phase Comparison Center Time		15.734kHz after F.B.P. input	9.9		11.5	μs
Increased/Reduced Voltage Characteristic of AFC Phase Comparison Center Time		V ₁₁ = 12±1V	-1.5		1.5	%/V
Temperature Characteristic of AFC Phase Comparison Center Time		Ta = -10 to +60°C	-0.2		0.2	%/°C
Comparison Waveform Generating Input Operation Voltage	V ₅		0.65		0.95	V
Pin 13 Voltage at Hold-down Operation Start	V ₁₄		0.55		0.85	V

Correspondence with the Existing IC Series

LA7858

LA7850
 LA7851 → LA7856
 LA7852
 LA7853 → LA7858

Type No.	Package	Vertical Pull-in Range	GND Pin
LA7850	DIP-20S	10Hz (at 60Hz)	Common to horizontal/vertical
LA7851, LA7856	DIP-20S	20Hz (at 60Hz)	Common to horizontal/vertical
LA7852	DIP-22S	10Hz (at 60Hz)	Separated for horizontal/vertical
LA7853, LA7858	DIP-22S	20Hz (at 60Hz)	Separated for horizontal/vertical

Package Dimensions

unit : mm (typ)
 3059A

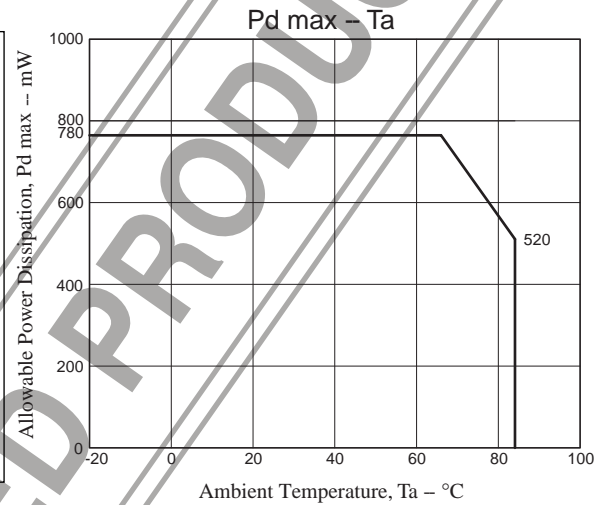
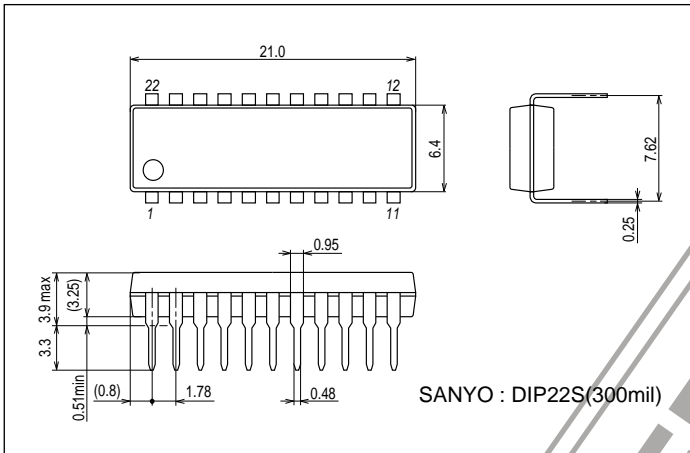

Block Diagram

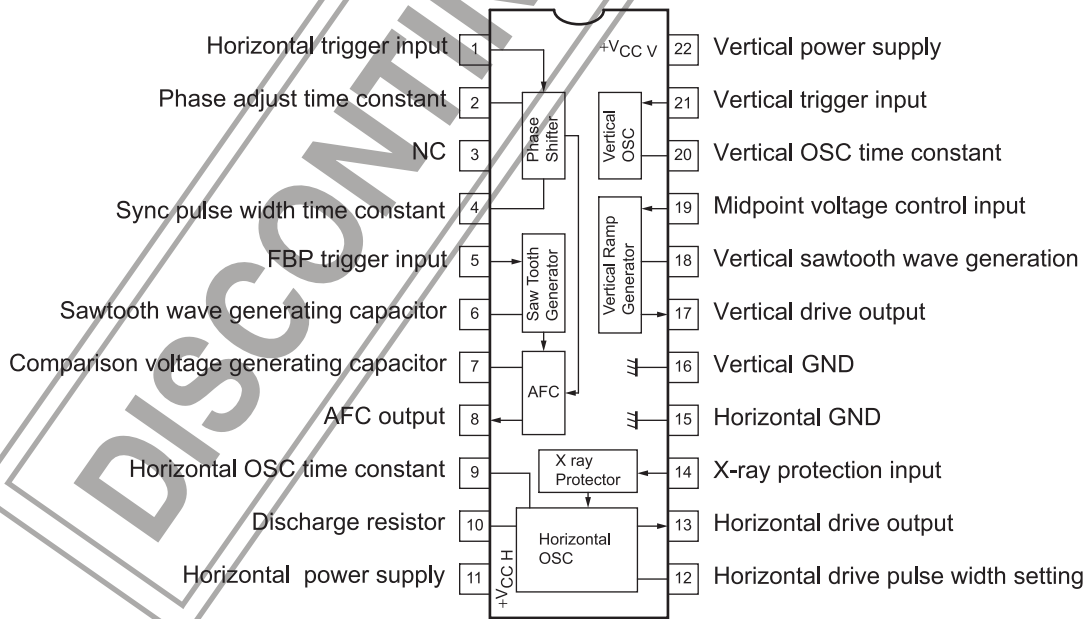

LA7858

Sample Application Circuit : 14" monitor

Vertical retrace time $\leq 700\mu\text{s}$

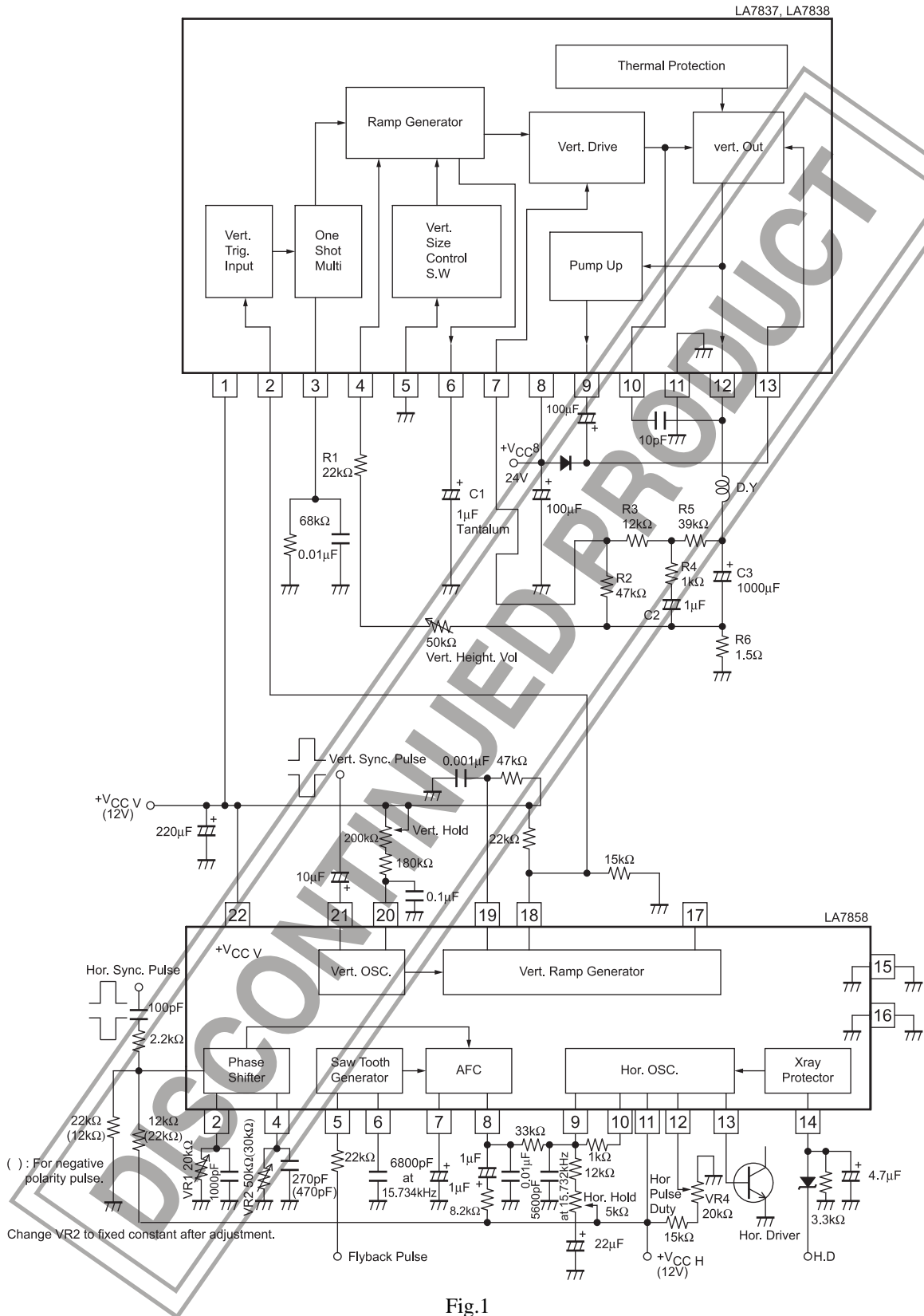

LA7858

Sample Application Circuit : 14" display

Vertical retrace time $\approx 300\mu\text{s}$

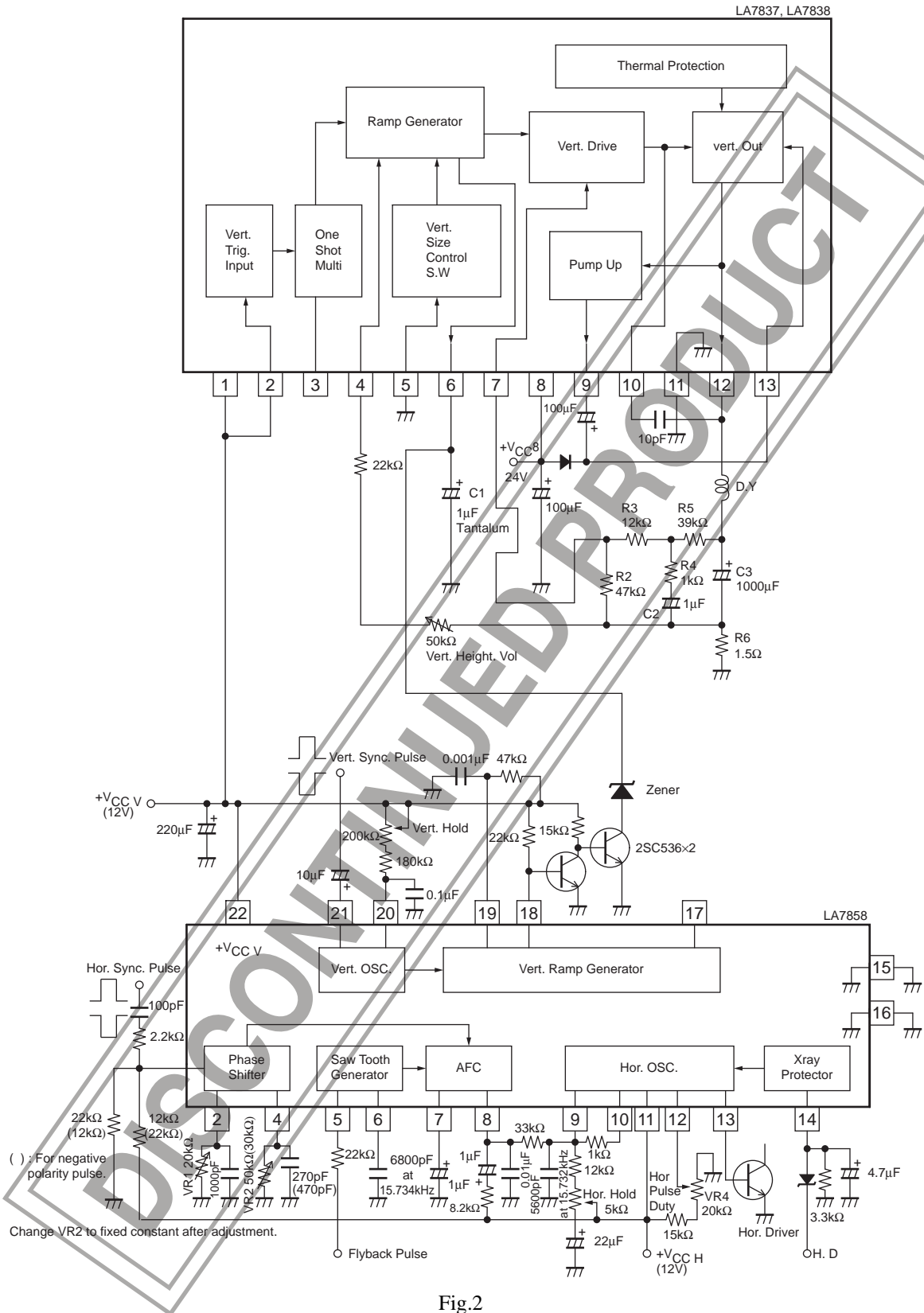

Fig.2

Precautions when using with vertical output ICs LA7837, 7838 :

The vertical output ICs LA7837, 7838 are appropriate for use in monitors and displays because the interlace and crossover distortion responses are superior to those of the LA7836.

However, since the vertical retrace time of displays is shorter than that of TV, the upper portion of the vertical picture may stretch. This is because the start waveform of the pin 6 sawtooth wave bends, as shown in Fig.3, due to the diode response of the clamp waveform. If there is not much time difference between T_1 and T_R , the upper portion of the vertical picture will tend to stretch. The use of a circuit as shown in Fig.2 will cause pin 6 waveform start wave to become linear, so that stretching is suppressed.

The example of circuit application shown in Fig.2 does not use the trigger input circuit (pin 2) and one-shot multivibrator (pin 3) built in the LA7837, 7838; the pin 6 sawtooth wave is controlled by the LA7856 vertical output pulse.

Therefore, the discharge circuit and clamp circuit are formed by the external Zener diode and transistor TR2.

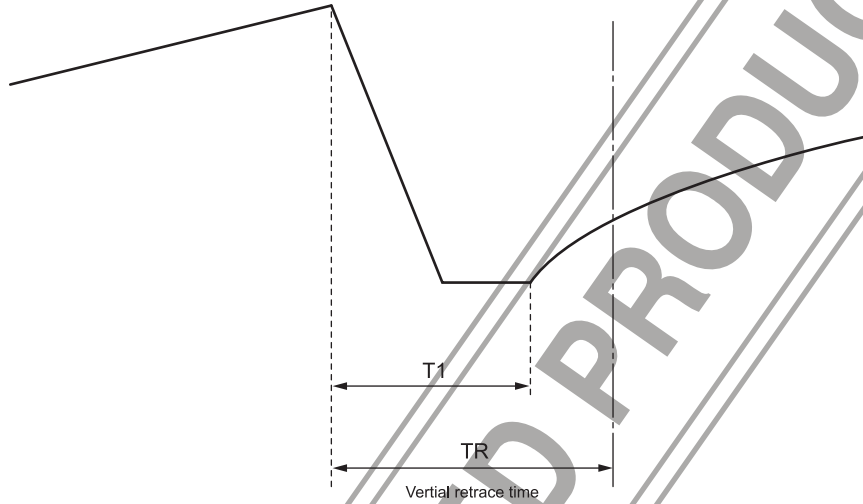

Fig.3

Design Example

For 12V pin 1 power supply

On the LA7837, 7838, pin 3 one-shot multivibrator operates when a trigger pulse enters pin 2.

During this time, the sawtooth wave generator discharge circuit and clamp circuit inside pin 6 operate.

The clamp voltage at this time is figured according to this formula :

$$V_{CLAMP} = 5/12 \cdot V_{CC} \dots\dots\dots \textcircled{1}$$

For 12V,

$$V_{CLAMP} = 5 \text{ [V]}$$

Therefore, the Zener diode used in Fig.2 must be rated more than 5V (e.g. 5.6V), otherwise the clamp circuit inside the IC will operate.

For 9V pin 1 power supply

The same as for 12V, according to formula $\textcircled{1}$:

$$V_{CLAMP} = 3.75 \text{ [V]}$$

So, the Zener diode must be rated more than 4V (e.g. 4.5V).

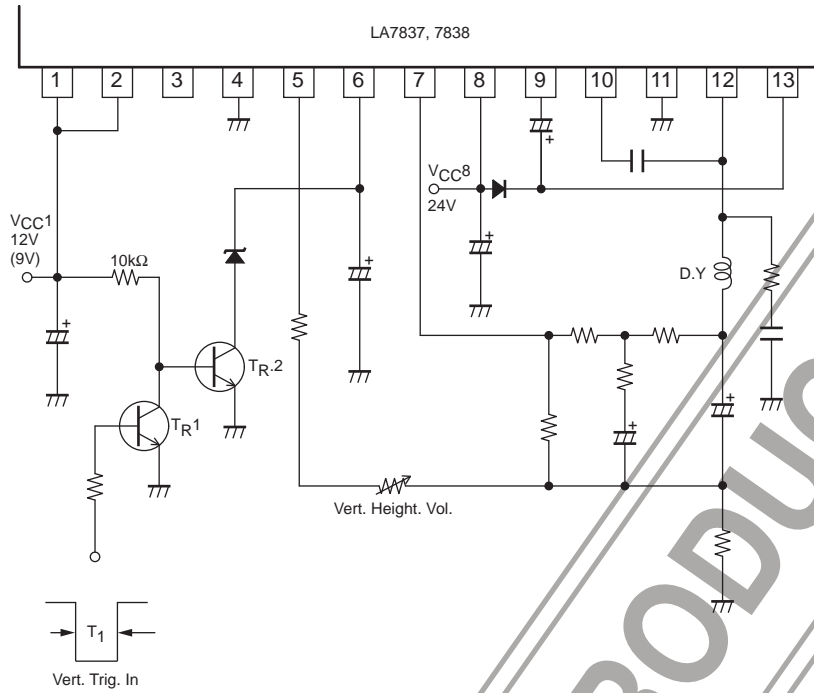
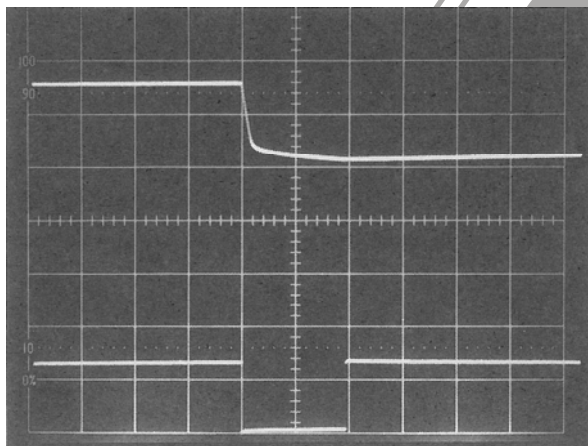

Fig.4

Pin 6 waveform when using the LA7837, 7838 in a display application circuit (Fig.2)



Pin 6 waveform 1 [V/div]
Horizontal : 100 [μs]

LA7857, 7858 pin 18 waveform
0.5 [V/div]
0V

Fig.5

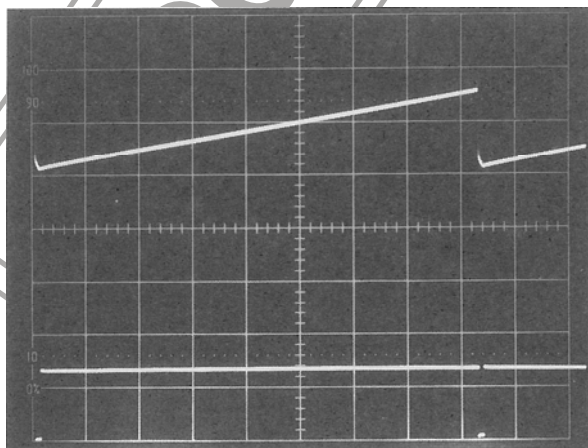

Pin 6 waveform 1 [V/div]
Horizontal : 2 [ms]

LA7857, 7858 pin 18 waveform
0.5 [V/div]
0V

Fig.6

UNVALUED PRODUCT

- SANYO Semiconductor Co.,Ltd. assumes no responsibility for equipment failures that result from using products at values that exceed, even momentarily, rated values (such as maximum ratings, operating condition ranges, or other parameters) listed in products specifications of any and all SANYO Semiconductor Co.,Ltd. products described or contained herein.
- SANYO Semiconductor Co.,Ltd. strives to supply high-quality high-reliability products, however, any and all semiconductor products fail or malfunction with some probability. It is possible that these probabilistic failures or malfunction could give rise to accidents or events that could endanger human lives, trouble that could give rise to smoke or fire, or accidents that could cause damage to other property. When designing equipment, adopt safety measures so that these kinds of accidents or events cannot occur. Such measures include but are not limited to protective circuits and error prevention circuits for safe design, redundant design, and structural design.
- In the event that any or all SANYO Semiconductor Co.,Ltd. products described or contained herein are controlled under any of applicable local export control laws and regulations, such products may require the export license from the authorities concerned in accordance with the above law.
- No part of this publication may be reproduced or transmitted in any form or by any means, electronic or mechanical, including photocopying and recording, or any information storage or retrieval system, or otherwise, without the prior written consent of SANYO Semiconductor Co.,Ltd.
- Any and all information described or contained herein are subject to change without notice due to product/technology improvement, etc. When designing equipment, refer to the "Delivery Specification" for the SANYO Semiconductor Co.,Ltd. product that you intend to use.
- Information (including circuit diagrams and circuit parameters) herein is for example only; it is not guaranteed for volume production.
- Upon using the technical information or products described herein, neither warranty nor license shall be granted with regard to intellectual property rights or any other rights of SANYO Semiconductor Co.,Ltd. or any third party. SANYO Semiconductor Co.,Ltd. shall not be liable for any claim or suits with regard to a third party's intellectual property rights which has resulted from the use of the technical information and products mentioned above.

This catalog provides information as of June, 2008. Specifications and information herein are subject to change without notice.