

MITSUBISHI ICs (TV)
M51354AP

TV IF SYSTEM

DESCRIPTION

The M51354AP is a semiconductor integrated circuit consisting of a VIF amplifier, video detector, SIF detector, IF/RF AGC, AFT, SIF limiting amplifier, quadrature FM demodulator, electronic attenuator and audio driver circuit. It provides in a single chip all color TV IF functions including video IF and sound IF.

The M51354AP is an effective means of providing high reliability and performance.

FEATURES

- High density packing with VIF, SIF and audio driver circuit on a single chip.
- High S/N ratio 57 dB, typ.
- Ceramic discriminator can be used for audio FM demodulation.
- Low noise Zener diode and audio circuit realize good hum rejection.
- De-Emphasis terminal can be used for the audio output terminal of the FM demodulator or for the audio input terminal of the attenuator.

APPLICATION

Color television receiver

RECOMMENDED OPERATING CONDITION

- Supply voltage range 10~14.5V
- Rated supply voltage 12V

PIN CONFIGURATION (TOP VIEW)

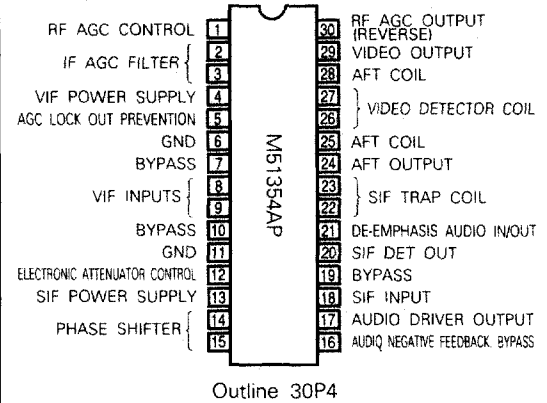

BLOCK DIAGRAM

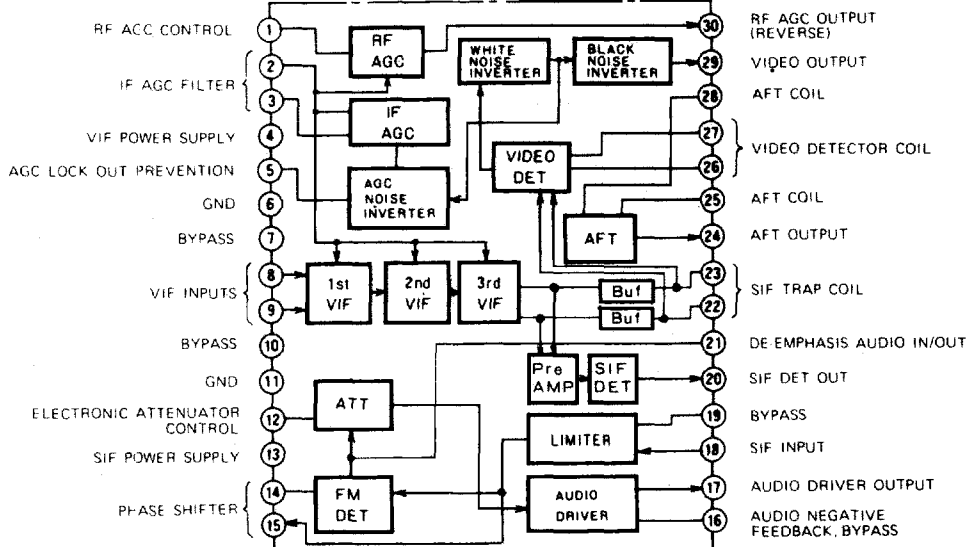

M51354AP

TV IF SYSTEM

ABSOLUTE MAXIMUM RATINGS

Symbol	Parameter	Rated	Unit
V _{CC}	Supply voltage	14.4	V
P _d	Power dissipation	1.6	W
T _{opr}	Operating temperature	-20-65	°C
T _{stg}	Storage temperature	-40-125	°C

ELECTRICAL CHARACTERISTICS (T_a=25°C, unless otherwise noted)

Symbol	Parameter	Test conditions	Limits			Unit
			Min.	Typ.	Max.	
I _{CC}	Circuit current	V _{CC} = 12V	45	70	89	mA
V _{in min}	Input sensitivity	f _p = 58.75MHz, CW Input level for 0.6V increase in V ₂₉	—	48	54	dBμ
V _{in max}	Maximum allowable input	f _p = 58.75MHz, CW Input level for 0.6V decrease in V ₂₉	100	105	—	dBμ
GR	AGC range	V _{in max} - V _{in min}	48	57	—	dB
V _{odet}	Video detector output	f _p = 58.75MHz, AM74%, f _m = 20kHz	1.75	2.15	2.55	V _{p-p}
BW	Video frequency response	f _p = 58.75MHz, CW, 90dBμ, f _B = 40-58MHz, 90dBμ (external AGC V ₂ = 0V)	8	12	—	MHz
V _{30H}	RF AGC maximum voltage	f _p = 58.75MHz, CW, 50dBμ V ₁ = 4V	9.4	9.8	—	V
						V
V _{30L}	RF AGC maximum voltage	f _p = 58.75MHz, CW, 105dBμ V ₁ = 5V		0	1.0	V
						V
μ	AFT detector sensitivity	For 100kΩ + 100kΩ load resistance	40	60	85	mV/kHz
V _{OAF max}	AF maximum output	f _p = 58.75MHz, CW, 80dBμ, V ₁₂ = 10V f _S = 54.25MHz, FM7.5kHzdev, f _m = 400Hz	800	1200	1600	mV _{rms}
LIM	Limiting sensitivity	f _S = 4.5MHz, FM 7.5kHzdev f _m = 400Hz Applied to pin 18	—	48	53	dBμ
AMR	AMR	f _S = 4.5MHz, AM 30%, f _m = 1kHz, 90dBμ Applied to pin 18	49	54	—	dB
V _{BTH}	Black spot inverter threshold level	f _C = 58.75 ± 5MHz, sweep 80dBμ External AGC, V ₂ = 5.8V	2.3	2.7	3.25	V
V _{BCL}	Black spot inverter clamp level		4.0	4.5	5.0	V
V _{WTH}	White spot inverter threshold level		6.6	7.0	7.4	V
V _{WCL}	White spot inverter clamp level		3.9	4.4	4.9	V

TYPICAL CHARACTERISTICS

THERMAL DERATING (MAXIMUM RATING)

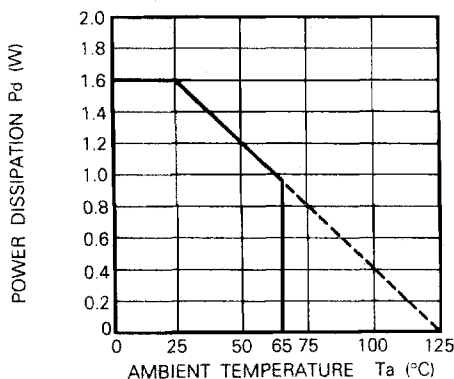

AGC CHARACTERISTICS

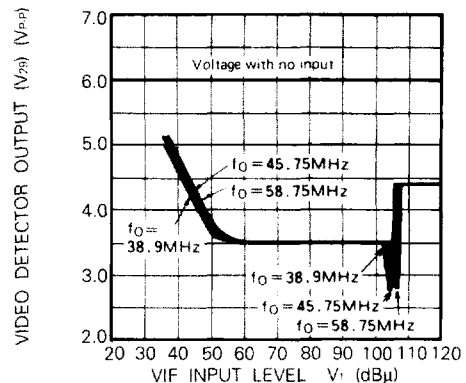

IF AGC VOLTAGE

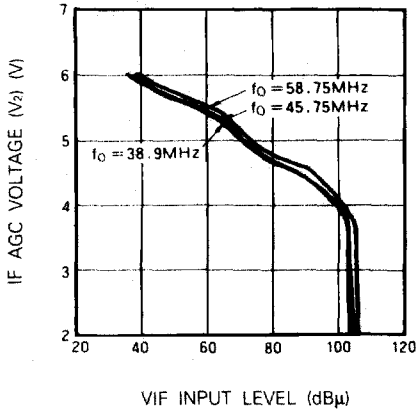

SIF LIMITING & AMR (SIF: 4.5MHz)

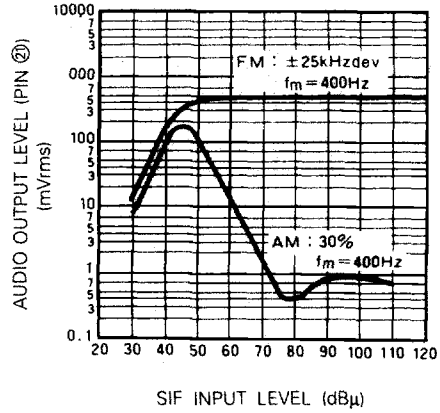

SIF LIMITING & AMR (SIF: 5.5MHz)

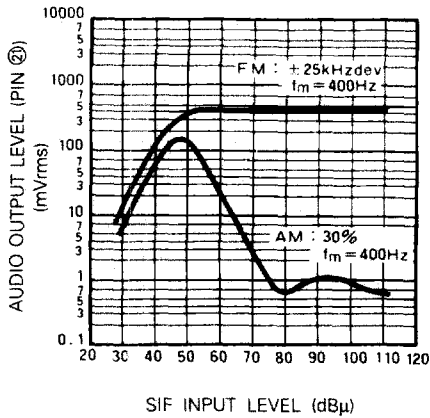

SIF FREQUENCY RESPONSE

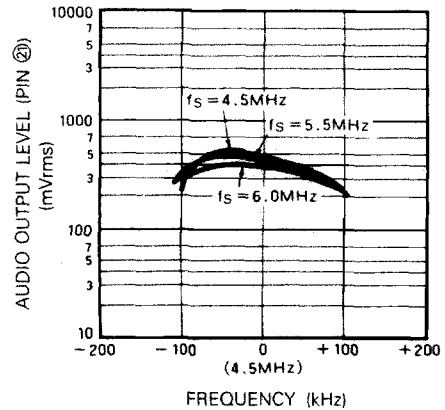

SIF LIMITING & AMR (6.0MHz)

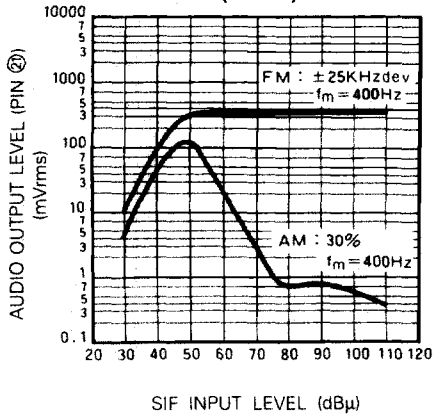

ELECTRONIC ATTENUATOR CONTROL CHARACTERISTICS

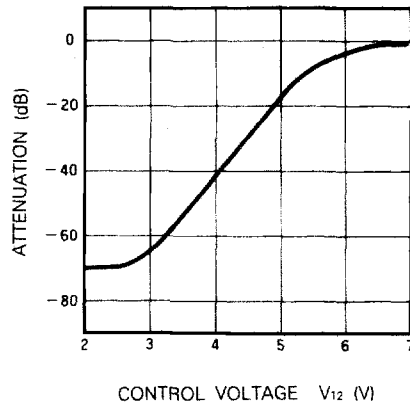

M51354AP

TV IF SYSTEM

AFT WIDE BAND CHARACTERISTICS

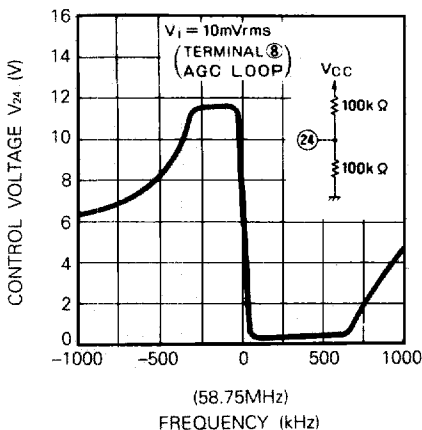

AFT NARROW BAND CHARACTERISTICS

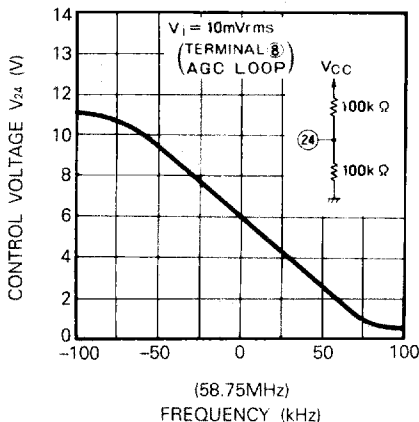

TERMINAL FUNCTIONS AND CONNECTION

Terminal ① RF AGC delay control

The threshold level at which the RF AGC output (terminal ③) begins to change can be adjusted by varying the terminal voltage using variable resistance. The C_1 connected to this terminal is for high-frequency bypass.

Terminal ② ③ IF AGC FILTER

Terminal ② and ③ are for levelling the IF AGC voltage. There is a 2-stage filter that provides a fast time constant and smooth output voltage. During the synchronous signal period, Q_1 is discharged from C_4 and C_2 , and during the asynchronous signal period, C_2 and C_4 are charged by the supply voltage through $10K\Omega$ and reach the peak of AGC. Choke coil L_1 prevents the ringing generated at the start of the synchronous signal during discharge, and C_3 prevents high frequency on the AGC voltage (terminal ②).

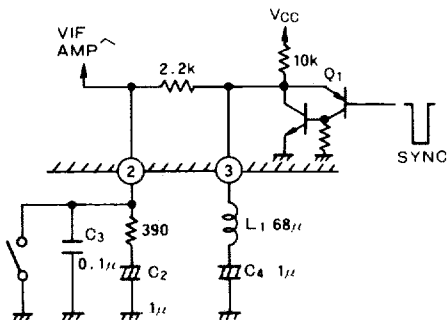

By grounding terminal ②, the gain in the VIF amplifier can be minimized and video output from the tuner stopped while playing back a video cassette recorder or using an other external video source.

Terminal ④ Power 1 (Vcc)

This is the power supply terminal for the VIF, AGC, video detector and AFT. Place decoupling condensers C_5 and C_6 as close as possible to terminal ⑥.

Terminal ⑤ AGC lock-out prevention

A condenser with a capacity of $0.1\mu \sim 0.47\mu F$ is normally used for this terminal. The AGC noise canceller works better with a large capacity, but will tend to develop an AGC lock-out. Conversely, if the capacity is small, there will be less incidence of lock-outs but the AGC noise canceller will be less effective.

The capacity must thus be determined by careful study of these factors in combination. An effective way of eliminating AGC lock-out is to couple a resistance of a few $100k\Omega$'s to the power supply.

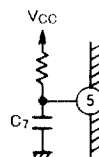

Terminal ⑥ GND₁

This is the GND terminal for the VIF, AGC, video detector and AFT. Its position in the layout must be considered very carefully, as it guards the site of the VIF amplifier terminal and prevents feedback from terminals with large signals, such as the output terminal. (Refer to the example PC board.)

Terminal ⑦ ⑩ Negative feedback bypass

This terminal is the DC feedback bypass from the output to the input side of the VIF amplifier, for stabilizing the bias. It bypasses the AC feedback from the output by way of condensers C_8 and C_{11} . Therefore C_8 and C_{11} must have superior high-frequency characteristics and should be placed as close to the IC terminal as possible, in order to stabilize amplifier performance.

Condenser C_{10} also serves to increase stability at high frequency levels.

M51354AP

TV IF SYSTEM

Terminals ⑧ ⑨ VIF inputs

Terminal ⑧ is of the same polarity as VIF output terminal ②; terminal ⑨ is an input terminal also, of the same polarity as terminal ②. Both terminals (⑧ and ⑨) should be connected to provide a balanced input, by coupling through condenser C_9 and by use of a transformer, as shown in the application example.

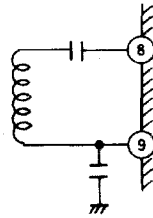

Although it is also possible to bypass one terminal, as shown above, and so to have a signal input, this will tend to adversely affect the gain as well as generate a difference in the amplitude between terminals ② and ③ when there is a large input. This method must therefore be tested before use. Transformer T_1 allows the IC to match the impedance and is effective in reducing the amount of noise outside the video IF band, and also serves to improve the S/N ratio in a weak electric field.

The turn ratios on the primary and secondary sides are determined by the matching impedance and gain. The input resistance on terminals ⑧ and ⑨ is approx. 800Ω , and turn ratios of 1:1 ~ 1:4 are appropriate.

The sensitivity of M51354AP at time of full gain is approx. $48\text{dB-}\mu\text{V}$; the maximum sensitivity is approx. $18\mu\text{V}$ when the gain in the tuner is 30dB.

A SAW filter behind the tuner will tend to cause a large loss; it is therefore necessary to make up for the loss with a preamplifier composed of Q_1 , $R_3\sim R_5$ and $C_{12}\sim C_{14}$, if the loss is as much as 20dB. (Gain 16~20dB.)

If the amount of loss due to the SAW filter is low, 10dB or less, the pre-amplifier is not required. (However, note that transformer T_1 is required to reduce the amount of noise.)

Terminal ⑪ GND2

This terminal is the GND for the SIF section. The PC board must also be laid out carefully in order to prevent any interference with VIF from SIF, just as when laying out terminal ⑥.

Terminal ⑫ Electronic attenuator control

The level of audio output to the ⑰ pin can be changed by changing the voltage level of the ⑫ pin. The minimum output is achieved at 2.0V and the maximum at 7.0V. The reference voltage of the attenuator is set at approx. 5.6V inside the IC, and any ripple in the electronic attenuator control voltage applied to the ⑫ pin comes out in the audio output. Therefore, in order to remove the ripples in ⑫ pin, provide a capacitor, C_{15} , that is as large as possible in a range that does not produce any abnormal noise when the power is turned on or off.

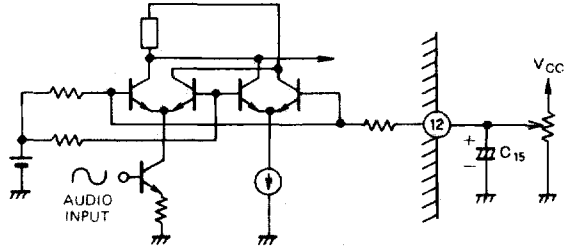

Terminal ⑬ Power 2 (Vcc)

This is the power supply for the SIF section. Connect C_{16} and C_{17} as close to the IC terminal as possible in order to prevent the harmonics generated by SIF from interfering with VIF. High frequency choke L_2 is effective in preventing interference deriving from the power supply.

Terminals ⑭ ⑮ FM detector phase shifter

M51354AP uses the quadrature method of detecting FM waves, and a phase shifter is connected between pins ⑭ and ⑮. It is connected as shown below when a ceramic discriminator is used. R_{16} and R_{17} are for matching and C_{18} is for phase shifting compensation.

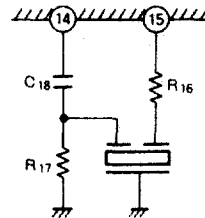

Frequency	Ceramic Filter (Manufactured by Murata Mfg. Co., Ltd.)	R_{16}	R_{17}	C_{18}
4.5MHz	CDA4.5MC	330 Ω	470 Ω	22 _p F
5.5MHz	CDA5.5MC	270 Ω	390 Ω	22 _p F
6.0MHz	CDA6.0MC	270 Ω	390 Ω	22 _p F

When using a coil, connect it as shown below, and refer to the separate list for the coil specifications.

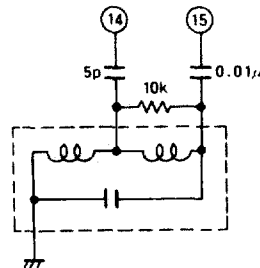

M51354AP

TV IF SYSTEM

Terminal ⑯ Audio negative feedback

Negative feedback is provided from the output stage and is to be externally connected to M51354AP for low distortion and stabilization. In the application example, the gain to the collector in the external transistor is shown as $1+R_5/R_6$. The audio gain to terminal ⑰ inside the IC is approximately 18dB (when $R_6 = 1.5k\Omega$).

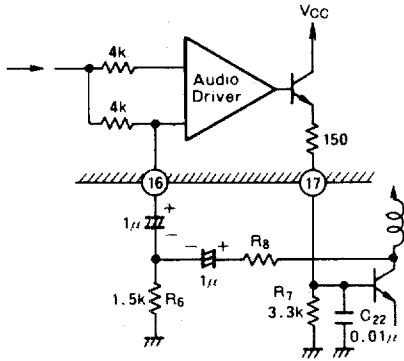

Terminal ⑰ Audio driver output

With the emitter follower output as shown in the diagram to the right, the output bias voltage is approx. 4.6V. R_7 is for the internal transistor bias. C_{22} is for high frequency bypass. And always add C_{22} to prevent oscillation.

Terminal ⑱ SIF input

This is the input terminal for the limiter amplifier. Its input limiting sensitivity is approx. 48dBμ. The bias resistance in the input is R_9 between terminals ⑱ and ⑲. When a large SIF signal is input to the limiting amplifier, the high frequency harmonics from SIF may interfere with VIF input and create noise stripes on the picture. If this should occur, set the input level at approx. 30mVrms.

Terminal ⑲ SIF input bias

C_{23} is for high frequency wave bypass. Set input bias resistance R_9 at 10kΩ or less in order to stabilize the amplifier. When using a ceramic filter, set bias resistance R_9 according to the table below for matching.

Frequency	Discriminator (Manufactured by Murata Mfg. Co., Ltd.)	R_9
4.5MHz	SFE4.5MB	1kΩ
5.5MHz	SFE5.5MB	600Ω
6.0MHz	SFE6.5MB	470Ω

When feeding in an external audio signal and emitting sound from the TV speakers, as when using a video cassette recorder for instance, the audio signal from the antenna can be muted by lowering the DC voltage of terminal ⑲ to 3.5V or less, or by raising it to 6V or higher.

Terminal ⑳ SIF detector output

This is the output terminal for the SIF detector (transistor detector). Normally SIF output level is approx. 90dBμV. It is connected to the ceramic filter through coupling condenser C_{24} .

When the audio S/N or buzz matters, insert a tuning circuit comprised of transformers between the terminal and the ceramic filter.

Terminal ㉑ De-emphasis, audio input/output

The audio output issues from terminal ㉑ before it reaches the electronic attenuator. Since the internal impedance is 24kΩ, approx. 3,000pF is appropriate for C_{25} for de-emphasis. Even when de-emphasis will not be used, always provide a 1000pF-capacity condenser in order to prevent any oscillation. The output from terminal ㉑ can be used as the recording terminal and the sound multiplex terminal. If the audio is muted by terminal ⑲ (refer to the explanation for terminal ⑲) and an audio signal from a VCR, for example, is input terminal ㉒, the audio can be emitted from the speaker through the electronic attenuator.

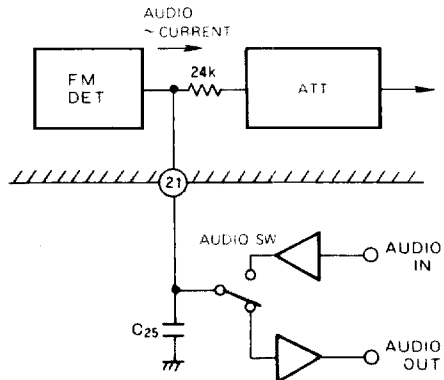

Terminal ㉒ SIF trap coil

By placing a shunted SIF trap in the VIF output as shown to the right, the impedance in the SIF is lowered and the SIF signals are reduced during transmission to the video detector. However, note that, if the SIF trap is so strong that the color carrier is attenuated, the beat may be increased reverse because of non-linearity. Select coils and condense with as high a Q level as possible. Refer to the table provided for the selection of coils.

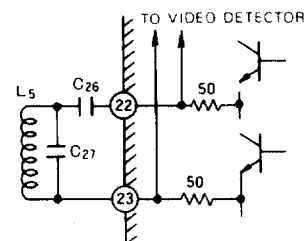

Example:

Frequency	C27	C26
54.25MHz	39pF	2pF
41.25MHz	95pF	7pF
33.4MHz	150pF	12pF

Terminal ⑭ AFT output

An S-curve, as shown below, is obtained. The voltage at pin ⑭ (V₂₄) is determined entirely by the divider R₁₀/R₁₁. C₂₈ is due to the high-frequency bypass.

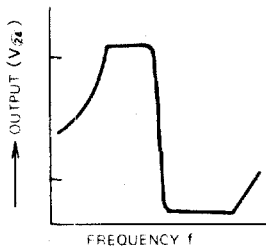

Terminal ⑮ ⑯ ⑰ ⑱ Video detector coil and AFT coil

L₆, C₂₉ and R₁₂ are tuned circuits for the video detector, and L₇ and C₂₉ are tuned circuits for AFT. The video detector and AFT are coupled by the stray capacity (approx. 1pF between terminals in the IC section plus the PC board capacity) of the neighboring terminals (⑮ ~ ⑱ and ⑰ ~ ⑲), at the appropriate level of 2pF. Set dumping resistance R₁₂ for the video detector to a few kΩ ~ a few tens of kΩ, according to the linearity of the demodulated output. Note that when the value of Q is too high, the gain in the carrier amplifier will fall too low when the tuning slips, and the video signal will be inverted.

The AFT defeat, e.g. when switching channels, is controlled by grounding this terminal through the AFT coil L₇ center tap, though R₁₂.C₃₁ is for high-frequency bypass.

Terminal ⑳ Video output

The internal connection is to an emitter follower output.

R₁₄ is the bias resistance (to be used at 1kΩ or higher) of the emitter follower.

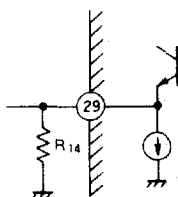

R₁₅ is used for impedance matching for the ceramic SIF trap, and L₈ secures the bias for the high-frequency choke and Q₂.

The video output at terminal ⑳ with no input is 6V, which is DC bias voltage. With signal input, the video output, whose synchronous signal polarity is negative, is 3.5V at the synchronous tip. The output level of the video signal is typically 2.1Vp-p.

Terminal ㉑ RF AGC output

The output polarity is gained in reverse AGC; approx. 10V is obtained in a weak electric field, 1V in a strong one. The delay point of RF AGC, as shown in the diagram below, shifts, according to the level of control voltage V₁ in terminal ①. Therefore, set the VIF amplifier input signals (of terminals ⑧ and ⑨) so that they never exceed the maximum allowable level, in accordance with the characteristics of the tuner.

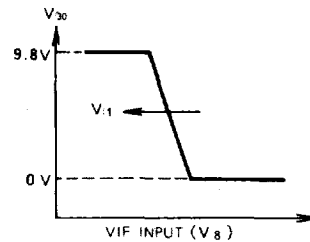

If the AGC loop oscillates due to the AGC characteristics of the tuner, a non-polar capacity of approx. 1μF placed between terminals ㉑ and ① is effective in eliminating such oscillation.

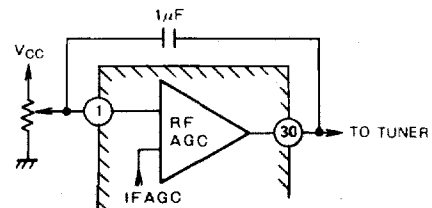

M51354AP

TV IF SYSTEM

Coil Data

VIF : 58.75MHz

PARTS	IC PIN	NUMBER	FREQUENCY	Q _u	C ₀ (pF)	TURNS	BOBBIN	WIRE	CONNECTION (Bottom View)
SOUND TRAP COIL	22-23	E502HN-5000205 (TOKO)	54.25MHz	225 ± 20%	37	(1-3)5 1/2t	Colored MC117	0.7φ Solder Plating	
VIDEO DET COIL	26-27	TKEEAS-27536FE (TOKO)	58.75MHz	88 ± 20%	27 Stray 7.2	(1-6)5t	10k Type	0.12φ OUEW	
AFT COIL	25-28	TKENS-27883RH (TOKO)	58.75MHz	72 ± 20%	59 ± 6%	(1-6)3t (1-3)1 1/2t	10k Type	0.12φ OUEW	

VIF : 45.75MHz

PARTS	IC PIN	NUMBER	FREQUENCY	Q _u	C ₀ (pF)	TURNS	BOBBIN	WIRE	CONNECTION (Bottom View)
SOUND TRAP COIL	22-23	E523LN-9990334 (TOKO)	41.25MHz	194 ± 20%	95 ± 6%	(1-2)4 3/4t	Colored MC117	0.7φ Solder Plating	
VIDEO DET COIL	26-27	TKEEAS-27537FE (TOKO)	45.75MHz	92 ± 20%	27 Stray 7.2	(1-6)6 1/2t	10k Type	0.12φ OUEW	
AFT COIL	25-28	BTKENS-27872RM (TOKO)	45.75MHz	84 ± 20%	59 ± 6%	(1-6)4 1/4t (1-3)2t (3-6)2 1/4t	10k Type	0.12φ OUEW	

VIF : 38.9MHz

PARTS	IC PIN	NUMBER	FREQUENCY	Q _u	C ₀ (pF)	TURNS	BOBBIN	WIRE	CONNECTION (Bottom View)
SOUND TRAP COIL	22-23	E523LN-9990324 (TOKO)	33.4MHz	154 ± 20%	150 ± 6%	(1-2)4 3/4t	Colored MC117	0.7φ Solder Plating	
VIDEO DET COIL	26-27	TKXEAS-27538FE (TOKO)	38.9MHz	92 ± 20%	27 Stray 7.2	(1-6)7 1/2t	10k Type	0.12φ OUEW	
AFT COIL	25-28	TKXNS-27884RM (TOKO)	38.9MHz	84 ± 20%	59 ± 6%	(1-6)5t (1-3)2 1/2t	10k Type	0.12φ OUEW	

Coil Data of FM Detector

PARTS	IC PIN	NUMBER	FREQUENCY	Q _u	C ₀ (pF)	TURNS	BOBBIN	WIRE	CONNECTION (Bottom View)
FM DET COIL	14-15	TKAC-27071BY (TOKO)	4.5MHz	68 ± 20%	82	(1-2)15 1/4t (2-3)16t	10k Type	0.12φ OUEW	
FM DET COIL	14-15	TKAC-26984Y (TOKO)	5.5MHz	60 ± 20%	82	(1-2)13t (2-3)13t	10k Type	0.12φ OUEW	

M51354AP

TV IF SYSTEM

M51354AP/M51383P 2 CHIP - COLOR TV SYSTEM

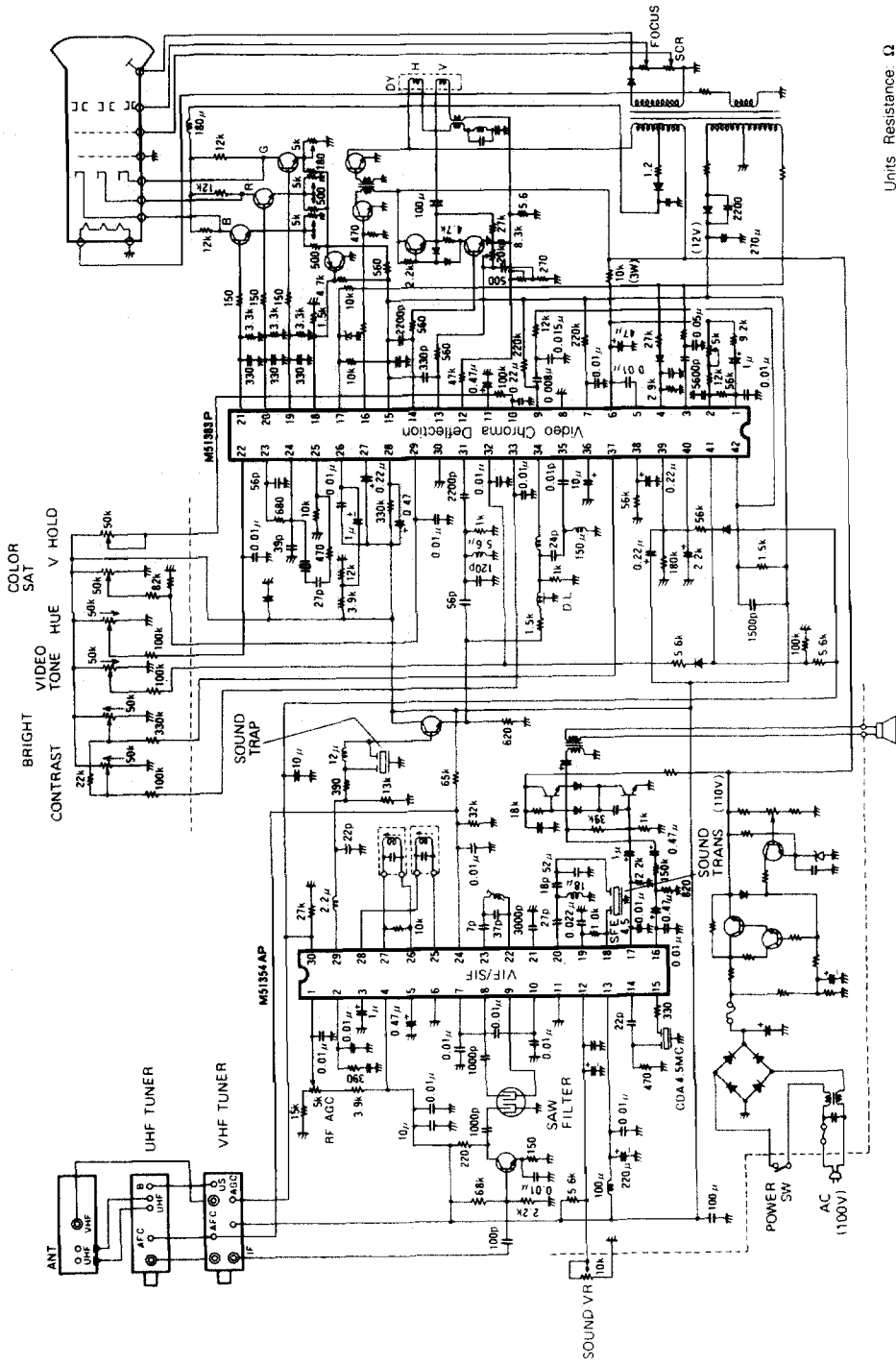

Units Resistance: Ω
Capacitance: F

M51354AP

TV IF SYSTEM

APPLICATION EXAMPLE

VIF : 58.75MHz
SIF : 4.5MHz

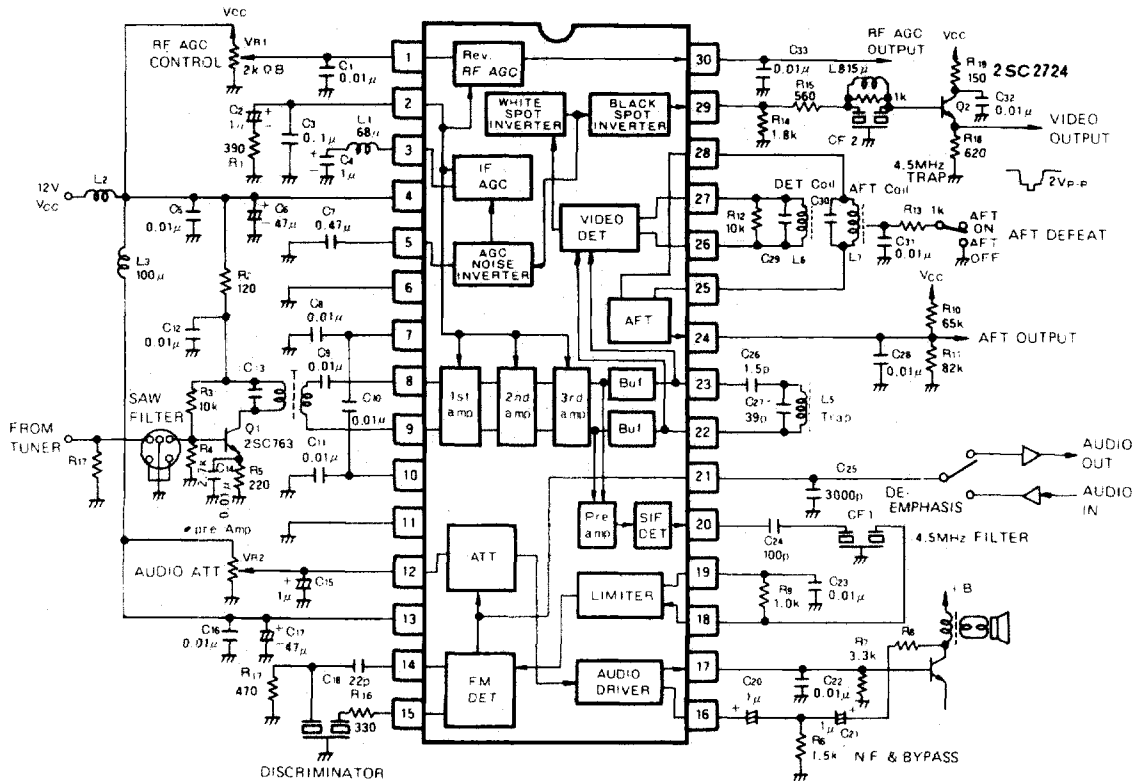

Units Resistance Ω
Capacitance F
Inductance H