

M51387P

3-CHANNEL VIDEO AMPLIFIER FOR HIGH-RESOLUTION COLOR DISPLAY

DESCRIPTION

The M51387P is a semiconductor integrated circuit that has a built-in 3-channel amplifier with 50MHz band, which is the 3rd version of Video AMP Series (M51392P/M51399P) with a broad band that is given a favorable reception in TV markets.

Every channel is provided with a broad-band amplifier, main/sub contrast control, main/sub luminance (brightness) control, peaking, blanking, and peak limiter functions. Accordingly, this IC is constructed so as to be most suitable for a high-resolution color display monitor.

FEATURES

- The employment of a new bi-polar wafer process makes it possible to reduce power dissipation, and 3 channels can be incorporated in this amplifier. (Vcc=12V, Icc = 77mA)
- Input : 1V_{P-P} (Typical)
Output : 6V_{P-P} (Maximum)
Frequency band : 50MHz
- Main and sub contrast and luminance controls are provided: the main control can change contrast and luminance at the same time for 3 channels, and the sub control can change them independently for each channel.
- The feedback circuit built in the IC can produce a stable DC level at the IC output pins.

PIN CONFIGURATION (TOP VIEW)

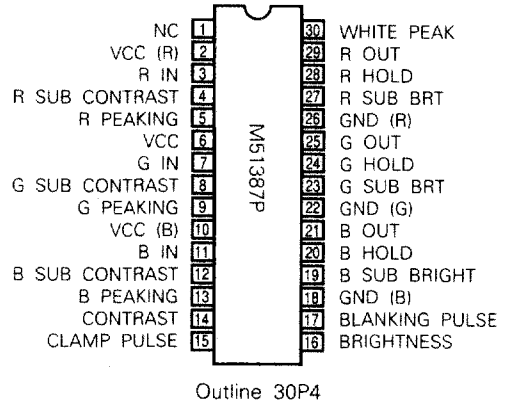

Outline 30P4

NC: No Connection

APPLICATION

CRT display

RECOMMENDED OPERATING CONDITION

Supply voltage range.....	11.0~12.5V
Rated supply voltage.....	12.0V

BLOCK DIAGRAM

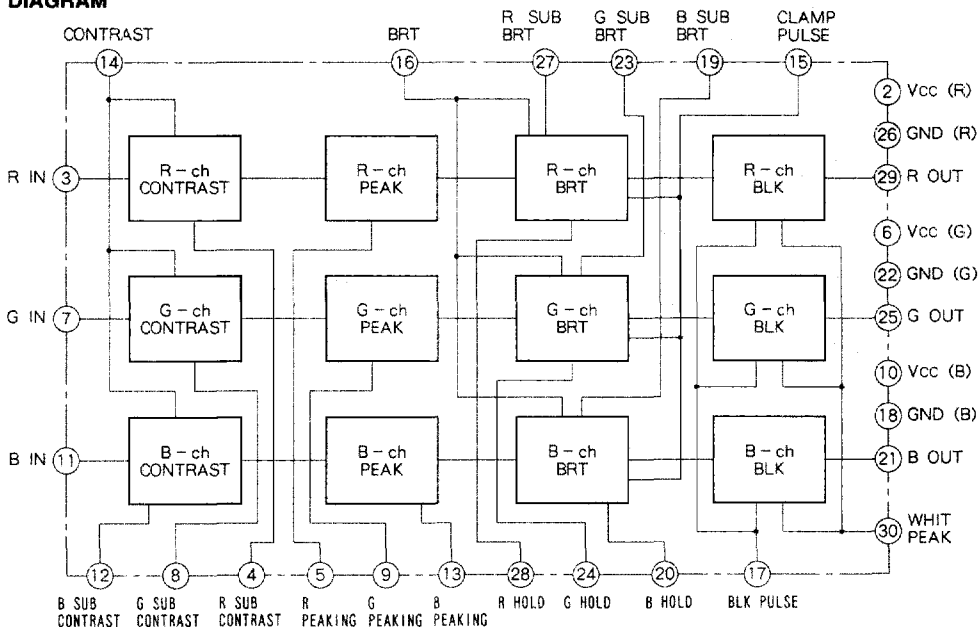

M51387P

3-CHANNEL VIDEO AMPLIFIER FOR HIGH-RESOLUTION COLOR DISPLAY

ABSOLUTE MAXIMUM RATING

Symbol	Parameter	Rating	Unit
V _{cc}	Supply voltage	14.0	V
P _d	Power dissipation	1670	mW
T _{opr}	Operating temperature	-20~65	°C
T _{stg}	Storage temperature	-40~125	°C

ELECTRICAL CHARACTERISTICS (T_a = 25°C, unless otherwise noted)

Symbol	Parameter	Test point	Test conditions											Limits			Unit	
			Input			External Supply Voltage (V)						Pulse		Min.	Typ.	Max.		
			SW3 R-ch	SW7 G-ch	SW11 B-ch	V4	V14	V16	SW V19	SW V20	V30	SW15 clamp	SW17 BLK					Note
I _{cc}	Circuit current	A	a	a	a	8.0	10.0	3.0	3.0	-	12.0	b SG6	b SG7	Note 1	60	77	94	mA
V _{omax}	Output dynamic range	TP21 TP25 TP29	b SG1	b SG1	b SG1	8.0	10.0	3.0	3.0	Variable	12.0	a	a	Note 2	6.1	7.1	8.1	V _{P-P}
V _{imax}	Maximum input voltage	TP21 TP25 TP29	b SG1	b SG1	b SG1	8.0	6.7	3.0	3.0	Variable	12.0	a	a	Note 3	1.5	2.2	2.9	V _{P-P}
G _v	Maximum gain	TP21 TP25 TP29	b SG1	b SG1	b SG1	8.0	10.0	3.0	3.0	V _T	12.0	a	a	Note 4	14.0	15.0	16.0	dB
Δ G _v	Relative maximum gain		Calculate the ratio.											Note 4	0.93	1.0	1.07	-
V _{CR1}	Contrast control characteristics (standard)	TP21 TP25 TP29	b SG1	b SG1	b SG1	8.0	6.7	3.0	3.0	V _T	12.0	a	a	Note 5	8.0	9.0	10.0	dB
Δ V _{CR1}	Relative contrast control characteristics (standard)		Calculate the ratio.											Note 5	0.9	1.0	1.1	-
V _{CR2}	Contrast control characteristics (minimum)	TP21 TP25 TP29	b SG1	b SG1	b SG1	8.0	3.0	3.0	3.0	V _T	12.0	a	a	Note 6	0	30	60	mV _{P-P}
Δ V _{CR2}	Relative contrast control characteristics (minimum)		Calculate the ratio.											Note 6	0.8	1.0	1.2	-
V _{SCR1}	Sub contrast control characteristics (standard)	TP21 TP25 TP29	b SG1	b SG1	b SG1	4.0	10.0	3.0	3.0	V _T	12.0	a	a	Note 7	5.5	7.5	9.5	dB
Δ V _{SCR1}	Relative sub contrast control characteristics (standard)		Calculate the ratio.											Note 7	0.9	1.0	1.1	-
V _{SCR2}	Sub contrast control characteristics (minimum)	TP21 TP25 TP29	b SG1	b SG1	b SG1	0.0	10.0	3.0	3.0	V _T	12.0	a	a	Note 8	0	30	60	mV _{P-P}
Δ V _{SCR2}	Relative sub contrast control characteristics (minimum)		Calculate the ratio.											Note 8	0.8	1.0	1.2	-
V _{CR3}	Contrast/sub contrast control characteristics (standard for both contrast and sub contrast)	TP21 TP25 TP29	b SG1	b SG1	b SG1	4.0	6.7	3.0	3.0	V _T	12.0	a	a	Note 9	0	1.5	3.0	dB
Δ V _{CR3}	Relative contrast/sub contrast control characteristics (standard for both contrast and sub contrast)		Calculate the ratio.											Note 9	0.9	1.0	1.1	-

M51387P

3-CHANNEL VIDEO AMPLIFIER FOR HIGH-RESOLUTION COLOR DISPLAY

ELECTRICAL CHARACTERISTICS (cont.)

Symbol	Parameter	Test point	Test conditions											Limits			Unit	
			Input			External Supply Voltage(V)						Pluse		Note	Min.	Typ.		Max.
			SW3 R-ch	SW7 G-ch	SW11 B-ch	V4	V14	V16	SW19 V19	SW20 V20	V30	SW15 clamp	SW17 BLK					
V _{B1}	Brightness control characteristics (maximum)	TP21 TP25 TP29	a	a	a	8.0	10.0	3.5	3.0	-	12.0	b SG6	a	Note 10	3.0	3.5	4.0	V _{DC}
Δ V _{B1}	Relative brightness control characteristics(maximum)		Calculate the ratio.											Note 10	- 150	0	150	mV
V _{B2}	Brightness control characteristics (minimum)	TP21 TP25 TP29	a	a	a	8.0	10.0	3.0	3.0	-	12.0	b SG6	a	Note 11	1.9	2.4	2.9	V _{DC}
Δ V _{B2}	Relative brightness control characteristics(minimum)		Calculate the ratio.											Note 11	- 150	0	150	mV
V _{SB}	Sub brightness control characteristics	TP21 TP25 TP29	a	a	a	8.0	10.0	3.0	3.5	-	12.0	b SG6	a	Note 12	1.3	1.8	2.3	V _{DC}
F _{C1}	Frequency characteristics I (f= 25 MHz, maximum)	TP21 TP25 TP29	b SG3	b SG3	b SG3	8.0	10.0	3.0	3.0	V _T	12.0	a	a	Note 13	0	2.5	5.0	dB
Δ F _{C1}	Relative frequency characteristics I (f= 25 MHz, maximum)		Calculate the ratio.											Note 13	- 1	0	1	dB
F _{C1'}	Frequency characteristics I (f= 50 MHz, maximum)	TP21 TP25 TP29	b SG3	b SG3	b SG3	8.0	10.0	3.0	3.0	V _T	12.0	a	a	Note 13	1.0	3.5	6.0	dB
Δ F _{C1'}	Relative frequency characteristics I (f= 50 MHz, maximum)		Calculate the ratio.											Note 13	- 1	0	1	dB
F _{C2}	Frequency characteristics II (f= 25 MHz, standard)	TP21 TP25 TP29	b SG3	b SG3	b SG3	8.0	6.7	3.0	3.0	V _T	12.0	a	a	Note 14	0	2.5	5.0	dB
F _{C2'}	Frequency characteristics II (f= 50 MHz, standard)	TP21 TP25 TP29	b SG4	b SG4	b SG4	8.0	6.7	3.0	3.0	V _T	12.0	a	a	Note 14	1.0	3.5	6.0	dB
F _{C3}	Frequency characteristics III (f= 25 MHz, minimum)	TP21 TP25 TP29	b SG3	b SG3	b SG3	8.0	3.0	3.0	3.0	V _T	12.0	a	a	Note 15	- 20.0	- 15.0	- 10.0	dB
F _{C3'}	Frequency characteristics III (f= 50 MHz, minimum)	TP21 TP25 TP29	b SG4	b SG4	b SG4	8.0	3.0	3.0	3.0	V _T	12.0	a	a	Note 15	- 15.0	- 10.0	- 5.0	dB
CT1	Crosstalk I (f = 10MHz)	TP21 TP25	b SG3	a	a	8.0	10.0	3.0	3.0	V _T	12.0	a	a	Note 16	-	- 48	- 43	dB
CT1'	Crosstalk I (f = 50MHz)	TP21 TP25	b SG4	a	a	8.0	10.0	3.0	3.0	V _T	12.0	a	a	Note 16	-	- 25	- 20	dB
CT2	Crosstalk II (f = 10MHz)	TP21 TP29	a	b SG3	a	8.0	10.0	3.0	3.0	V _T	12.0	a	a	Note 17	-	- 48	- 43	dB
CT2'	Crosstalk II (f = 50MHz)	TP21 TP29	a	b SG4	a	8.0	10.0	3.0	3.0	V _T	12.0	a	a	Note 17	-	- 25	- 20	dB
CT3	Crosstalk III (f = 10MHz)	TP25 TP29	a	a	b SG3	8.0	10.0	3.0	3.0	V _T	12.0	a	a	Note 18	-	- 48	- 43	dB
CT3'	Crosstalk III (f = 50MHz)	TP25 TP29	a	a	b SG4	8.0	10.0	3.0	3.0	V _T	12.0	a	a	Note 18	-	- 25	- 20	dB

3-CHANNEL VIDEO AMPLIFIER FOR HIGH-RESOLUTION COLOR DISPLAY

ELECTRICAL CHARACTERISTICS (cont.)

Symbol	Parameter	Test point	Test conditions											Limits			Unit	
			Input			External Supply Voltage (V)						Pulse		Note	Min.	Typ.		Max.
			SW3 R-ch	SW7 G-ch	SW11 B-ch	V4	V14	V16	SW V19	SW V20	V30	SW15 clamp	SW17 BLK					
T _r	Pulse characteristics I	TP21 TP25 TP29	b SG5	b SG5	b SG5	8.0	10.0	3.0	3.0	V _T	12.0	a -	a -	Note 19	-	5.0	10	nsec
T _r	Pulse characteristics II	TP21 TP25 TP29	b SG5	b SG5	b SG5	8.0	10.0	3.0	3.0	V _T	12.0	a -	a -	Note 19	-	7.0	12	nsec
V _{15th}	Clamp pulse threshold voltage	TP21 TP25 TP29	a -	a -	a -	8.0	10.0	3.0	3.0	-	12.0	b SG6	a -	Note 20	0.6	1.1	1.6	V _{DC}
V _{17th}	Blanking pulse threshold voltage	TP21 TP25 TP29	a -	a -	a -	8.0	10.0	3.0	3.0	-	12.0	b SG6	b SG7	Note 21	0.6	1.1	1.6	V _{DC}
W ₁₅	Clamp pulse minimum width	TP21 TP25 TP29	a -	a -	a -	8.0	10.0	3.0	3.0	-	12.0	b SG6	a -	Note 22	-	0.7	1.5	μ sec
T _{dr}	Blanking pulse delay time I	TP21 TP25 TP29	a -	a -	a -	8.0	10.0	3.0	3.0	-	12.0	b SG6	b SG7	Note 23	-	0.3	0.6	μ sec
T _{dr}	Blanking pulse delay time II	TP21 TP25 TP29	a -	a -	a -	8.0	10.0	3.0	3.0	-	12.0	b SG6	b SG7	Note 23	-	50	100	nsec
V _{BLK}	Blanking output level	TP21 TP25 TP29	a -	a -	a -	8.0	10.0	3.0	3.0	-	12.0	b SG6	b SG7	Note 24	-	0.01	0.2	V _{DC}
V _{20'}	Hold voltage	TP20 TP24 TP28	a -	a -	a -	8.0	10.0	3.0	3.0	-	12.0	b SG6	a -	Note 25	3.7	4.2	4.7	V _{DC}
WP1	White peak clip level I	TP21 TP25 TP29	b SG1	b SG1	b SG1	8.0	10.0	3.0	3.0	V _T	8.0	a -	a -	Note 26	2.9	3.4	3.9	V _{DC}
WP2	White peak clip level II	TP21 TP25 TP29	b SG1	b SG1	b SG1	8.0	10.0	3.0	3.0	V _T	6.0	a -	a -	Note 26	1.0	1.5	2.0	V _{DC}
V	Clamp level temperature coefficient	TP21 TP25 TP29	a -	a -	a -	8.0	10.0	3.5	-	-	12.0	b SG6	a -	Note 27	-1.0	0	1.0	mV/°C

3-CHANNEL VIDEO AMPLIFIER FOR HIGH-RESOLUTION COLOR DISPLAY

ELECTRICAL CHARACTERISTICS TEST METHOD

The switch (SW) numbers for the signal input pin and pulse input pin have already been given in the "Electrical Characteristics" paragraph above; therefore, only the switch numbers for the external power supply will be given in the following notes.

V4, V8, V12 or V19, V23, V27 or V20, V24, V28 are normally set at the same value, which are all represented by V4, V19 and V20 in "Electrical Characteristics."

V19, V23 and V27 voltage is set by changing the 10 k variable resistor when each pin is open.

For example, 3V is set. refer to the following.

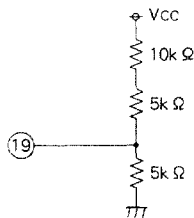

Hereafter, set V19, V23 and V27 voltage under the same conditions.

Note1: Circuit current I_{cc}

- SW19, SW23 and SW27 are all fixed on side "a." V19, V23 and V27 are set at 3.0V, and SW20, SW24 and SW28 are all fixed on side "b."
- The other conditions are as shown in "Electrical Characteristics." When SW2 is fixed on side "a," I_{cc} is measured, using ampere meter (ammeter) A.

Note2: Output dynamic range V_{omax}

- SW19, SW23 and SW27 are all fixed on side "b," and SW20, SW24 and SW28 are all fixed on side "a."
- V20 is set up in the following order:
 - SG1 is input to pin ③ (pins ⑦, ⑩). Voltage V20 is gradually increased, and when the upper side of the TP21 (TP25 and TP29) output waveform becomes distorted, V20 is read, which is taken as V_{TR1} (V_{TG1}, V_{TB1}).

In contrast to the above, when voltage V20 is gradually reduced, and the bottom side of TP21 (TP25, TP29) output waveform becomes distorted, V20 is read, which is taken as V_{TR2} (V_{TG2}, V_{TB2}).

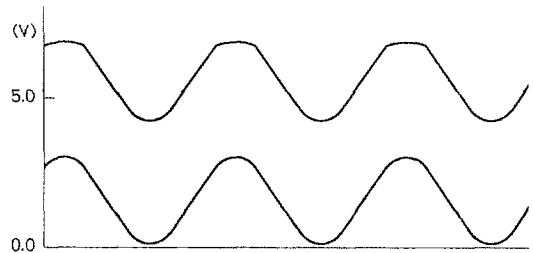

- Accordingly, V_T (V_{TR}, V_{TC}, V_{TB}) is found by the following:

$$V_{TR}(V_{TG}, V_{TB}) = \frac{V_{TR1}(V_{TG1}, V_{TB1}) + V_{TR2}(V_{TG2}, V_{TB2})}{2}$$

This equation should be used properly, depending on the output pin.

When TP29 is measured, V_{TR} should be used, and when TP25 and TP21 are measured, V_{TG} and V_{TB} should be used respectively.

- After V_{TR} (V_{TG}, V_{TB}) is set, gradually increase the amplitude of SG1, and measure the amplitude of the output waveform when the output waveform of TP29 (TP25, TP21) starts distortion.

Note3: Maximum input voltage V_{imax}

From the condition in NOTE 2 above, change V14 to 6.7V as given in "Electrical Characteristics," gradually increase the amplitude of the input signal from 500 mV_{P-P}, and read the input signal amplitude when the output signal starts to be distorted.

Note4: Maximum gain G_v

- Fix SW19, SW23, SW27 and SW20, SW24, SW28 on sides "b" and "a," and also set the conditions as shown in "Electrical Conditions."
- Input SG1 to pin ③ (pin ⑦, pin ⑩) and read the amplitude of TP29 (TP25/TP21) output at this time: it should be taken as V_{OR1} (V_{OG1}, V_{OB1}).
- The maximum gain G_v is determined by:

$$G_v = 20 \log \frac{V_{OR1} (V_{OG1}, V_{OB1}) [V_{P-P}]}{0.5 [V_{P-P}]}$$

- The relative maximum gain ΔG_v is calculated as follows:

$$\Delta G_v = V_{OR1}/V_{OG1}, V_{OG1}/V_{OB1}, V_{OB1}/V_{OR1}$$

3-CHANNEL VIDEO AMPLIFIER FOR HIGH-RESOLUTION COLOR DISPLAY

Note5: Contrast control characteristics (standard)**V_{CR1}**

1. The conditions are the same as in NOTE 4-1 above except that V14 (CONTRAST) is set at 6.7V.
2. Read the amplitude of TP29 (TP25/TP21) output at this time: it should be taken as V_{OR2}(V_{OG2}/V_{OB2}).
3. The contrast control characteristics V_{CR1} and relative contrast control characteristics ΔV_{CR1} are calculated as follows:

$$V_{CR1} = 20 \log \frac{V_{OR1} (V_{OG1}, V_{OB1}) [V_{D-P}]}{0.5 [V_{D-P}]}$$

$$\Delta V_{CR1} = V_{OR2}/V_{OG2}, V_{OG2}/V_{OB2}, V_{OB2}/V_{OR2}$$

Note6: Contrast control characteristics (minimum)**V_{CR2}**

1. The conditions are the same as in NOTE 4-1 above except that V14 (CONTRAST) is set at 3.0V.
2. Read the amplitude of TP29 (TP25/TP21) output at this time: the three readings are referred to generally as V_{CR2}, and respectively as V_{OR3} (V_{OG3}/V_{OB3}).
3. The relative contrast control characteristics ΔV_{CR2} is: ΔV_{CR2}=V_{OR3}/V_{OG3}, V_{OG3}/V_{OB3}, V_{OB3}/V_{OR3}

Note7: Sub contrast control characteristics (standard) V_{SCR1}

1. The conditions are the same as in NOTE 4-1 except that V4 (SUB CONTRAST) is set at 4.0V.
2. Read the amplitude of TP29 (TP25/TP21) at this time: it should be taken as V_{OR4}(V_{OG4}/V_{OB4}).
3. The sub contrast control characteristics V_{SCR1} and relative sub contrast control characteristics ΔV_{SCR1} are found by:

$$V_{SCR1} = 20 \log \frac{V_{OR4} (V_{OG4}, V_{OB4}) [V_{D-P}]}{0.5 [V_{D-P}]}$$

$$\Delta V_{SCR1} = V_{OR4}/V_{OG4}, V_{OG4}/V_{OB4}, V_{OB4}/V_{OR4}$$

Note8: Sub contrast control characteristics (minimum) V_{SCR2}

1. The conditions are the same as in NOTE 4-1 above except that V4 (SUB CONTRAST) is set at 0.0V.
2. Read the amplitude of TP29 (TP25/TP21) output at this time: the three readings are referred to generally as V_{SCR2}, and respectively as V_{OR5} (V_{OG5}/V_{OB5}).
3. The relative sub contrast control characteristics ΔV_{SCR2} is:
ΔV_{SCR2}=V_{OR5}/V_{OG5}, V_{OG5}/V_{OB5}, V_{OB5}/V_{OR5}

Note9: Contrast/sub contrast control characteristics (standard) V_{CR3}

1. The conditions are the same as in NOTE 4-1 above except that V14s (CONTRAST) and V4 (SUB CONTRAST) are set at 6.7V and 4.0V respectively.
2. Read the amplitude of TP29 (TP25/TP21) output at this time: it should be taken as V_{OR6}(V_{OG6}/V_{OB6}).
3. The gain and relative gain when the contrast and sub contrast are standard are determined by:

$$V_{CR3} = 20 \log \frac{V_{OR6} (V_{OG6}, V_{OB6}) [V_{D-P}]}{0.5 [V_{D-P}]}$$

$$\Delta V_{CR3} = V_{OR6}/V_{OG6}, V_{OG6}/V_{OB6}, V_{OB6}/V_{OR6}$$

Note10: Brightness control characteristics (maximum)**V_{B1}**

1. Fix SW19, SW23, SW27 and SW20, SW24, SW28 on sides "a" and "b" respectively, and set the conditions as given in "Electrical Characteristics."
2. Measure the output of TP29 (TP25/TP21) at this time with a voltmeter: it should be taken as V_{OR5} (V_{OG5}/V_{OB5}). This value is V_{B1}.
3. Also calculate the difference between each channel from V_{OR5}, V_{OG5} and V_{OB5}.

The relative brightness control characteristics ΔV_{B1} is found by:

$$\Delta V_{B1} = V_{OR5} - V_{OG5} \text{ (mV)}$$

$$= V_{OG5} - V_{OB5}$$

$$= V_{OB5} - V_{OR5}$$

Note11: Brightness control characteristics (minimum)**V_{B2}**

1. Fix SW19, SW23, SW27 and SW20, SW24, SW28 on sides "a" and "b" respectively, and set the conditions as given in "Electrical Characteristics."
2. Measure the output of TP29 (TP25/TP21) at this time using a voltmeter: it should be taken as V_{OR5} (V_{OG5}/V_{OB5}). This value is V_{B2}.
3. Also calculate the difference between each channel from V_{OR5}, V_{OG5} and V_{OB5}.

The relative brightness control characteristics ΔV_{B2} is:

$$\Delta V_{B2} = V_{OR5} - V_{OG5} \text{ (mV)}$$

$$= V_{OG5} - V_{OB5}$$

$$= V_{OB5} - V_{OR5}$$

Note12: Sub brightness control characteristics V_{SB}

The conditions are the same as given in NOTE 10 above except that SUB Brt (V19, V23, V27) is set at 3.5V or 2.5V. However, NOTE 10-3 is not included in the conditions.

3-CHANNEL VIDEO AMPLIFIER FOR HIGH-RESOLUTION COLOR DISPLAY

Note13: Frequency characteristics I Fc1, Fc1'

1. Fix SW19, SW23, SW27 and SW20, SW24, SW28 on sides "b" and "a" respectively, and set the conditions as shown in "Electrical Characteristics."
2. Input SG2 to pin ③ (pins ⑦, ⑪) and measure the input pin at 100 kHz with a spectrum analyzer: it should be taken as f₁.
3. Measure each output at 100kHz, 25MHz and 50MHz in frequency: the measurements should be taken as f₂, f₃ and f₄ respectively.

Next, find the frequency characteristics at each point.

- f_(R)=f₂-f₁(dB) Gain at 100kHz
- f'_(R)=f₃-f₁(dB) Gain at 25MHz
- f''_(R)=f₄-f₁(dB) Gain at 50MHz

* The above values are available for 3 channels.

4. The frequency characteristics Fc1, Fc1' are determined by:

$$F_{C1} = f'_{(R)} - f_{(R)} \text{ or } f'_{(G)} - f_{(G)} \text{ or } f'_{(B)} - f_{(B)} \text{ (dB)}$$

$$F_{C1}' = f''_{(R)} - f_{(R)} \text{ or } f''_{(G)} - f_{(G)} \text{ or } f''_{(B)} - f_{(B)} \text{ (dB)}$$

5. The relative frequency characteristics ΔFc1, ΔFc1' are found by calculating the difference between Fc1 and Fc1' for each channel.

Note14: Frequency characteristics II Fc2, Fc2'

The conditions are the same as in NOTE 13 above except that CONTRAST (V14) is reduced to 6.7V. However, NOTE 13-5 is excluded from the conditions.

Note15: Frequency characteristics III Fc3, Fc3'

The ratio of output to input when CONTRAST (V14) is reduced to 3.0V is measured; that is, the conditions correspond to f'_(R) and f''_(R) in NOTE 13-3 above.

Note16: Crosstalk I CT1

1. Fix SW19, SW23, SW27, and SW20, SW24, SW28 on sides "b" and "a" respectively, and set the conditions as given in "Electrical Characteristics."
2. Input SG3 (or SG4) to pin ③ (R-ch) only and measure the amplitude of output waveforms on TP29, TP25 and TP21 at that time: these measurements should be taken as V_{OR}, V_{OG} and V_{OB}.
3. The crosstalk CT1 is determined by:

$$CT1 = 20 \log \frac{V_{OG} \text{ or } V_{OB} [V_{P-P}]}{V_{OR} [V_{P-P}]}$$

Note17: Crosstalk II CT2

1. Change the input pin from pin ③ (R-ch) to pin ⑦ (G-ch), and read the output in the same manner as in NOTE 16 above.

2. The crosstalk CT2 is determined by:

$$CT2 = 20 \log \frac{V_{OR} \text{ or } V_{OB} [V_{P-P}]}{V_{OG} [V_{P-P}]} \text{ (dB)}$$

Note18: Crosstalk III CT3

1. Change the input pin from pin ③ (R-ch) to pin ⑪ (B-ch), and read the output in the same manner as in NOTE 16 above.
2. The crosstalk CT3 is determined by:

$$CT3 = 20 \log \frac{V_{OR} \text{ or } V_{OB} [V_{P-P}]}{V_{OG} [V_{P-P}]} \text{ (dB)}$$

Note19: Pulse characteristics I, II Tr, Tf

1. Fix SW19, SW23, SW27 and SW20, SW24, SW28 on sides "b" and "a" respectively, and set the conditions as given in "Electrical Characteristics."
2. Measure the rise time Tr1 and fall time Tr2 between 10 and 90% of the input pulse with an active probe.
3. Next, measure the rise time Tr2 and fall time Tr2 between 10 and 90% of the output pulse with an active probe.
4. The pulse characteristics Tr, Tf are found by:

$$Tr(\text{nsec}) = \sqrt{(Tr2)^2 - (Tr1)^2}$$

$$Tf(\text{nsec}) = \sqrt{(Tr2)^2 - (Tr1)^2}$$

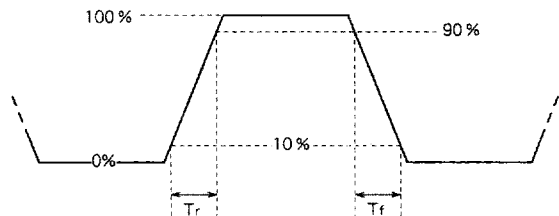

Note20: Clamp pulse threshold voltage V15th

1. Fix SW19, SW25, SW27 and SW20, SW23, SW28 on sides "a" and "b" respectively, and set the conditions as given in "Electrical Characteristics."
2. While monitoring the output (approx. 2.0V_{DC}) at this time, lower the SG6 level gradually and measure the SG3 level when the output reaches 0V.

Note21: Blanking pulse threshold voltage V17th

In addition to the conditions in NOTE 19 above, the output waveform is as shown below if SG7 is input. Lower the SG7 level gradually now and measure the SG7 level when the BLK portion disappears.

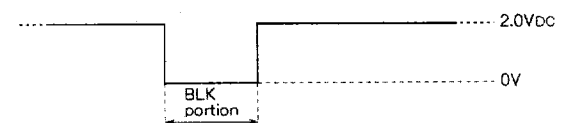

3-CHANNEL VIDEO AMPLIFIER FOR HIGH-RESOLUTION COLOR DISPLAY

Note22: Clamp pulse minimum width W_{15}

While monitoring the output under the conditions given in NOTE 19 above, decrease the SG6 pulse width gradually.

Also measure the SG6 pulse width when the output becomes 0V.

Note23: Blanking pulse delay time I, II, T_{df} , T_{dr}

For the relationship between the output waveform and SG7 under the conditions given in NOTE 20, T_{df} and T_{dr} , refer to the following.

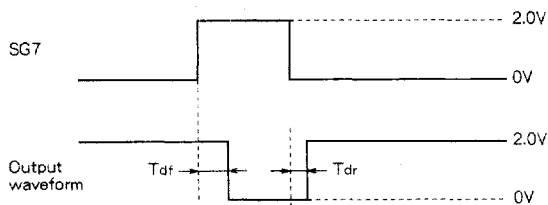
**Note24: Blanking output level V_{BLK}**

Measure DC value at the BLK part under the conditions given in NOTE 23 above.

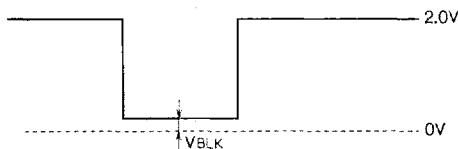
**Note25: Hold voltage V_{20}**

1. Fix SW19, SW23, SW27 and SW20, SW24, SW28 on sides "a" and "b" respectively, and set the conditions given in "Electrical Characteristics."
2. Read TP20, TP24 and TP28 with a voltmeter.

Note26: White peak clip level I, II, WP1, 2



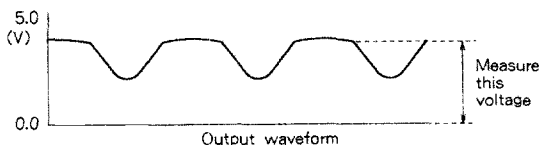

1. Fix SW19, SW23, SW27 and SW20, SW24, SW28 on sides "b" and "a" respectively, and set the conditions given in "Electrical Characteristics."
2. Read the DC value at the upper part of the output waveform at this time.

**Note27: Clamp level temperature coefficient V**

1. For the test circuit, use "2." (Connect pins ⑬, ⑭, ⑮ with V_{CC} through 82k.)
2. Fix SW19, SW23, SW27 and SW20, SW24, SW28 on sides "a" and "b" respectively, and set the conditions given in "Electrical Characteristics."
3. Measure the clamping level at each temperature according to the procedure specified in NOTE 11 above.

3-CHANNEL VIDEO AMPLIFIER FOR HIGH-RESOLUTION COLOR DISPLAY

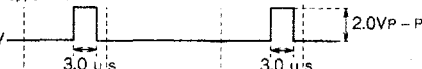
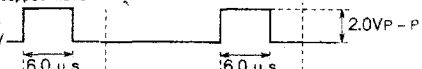
INPUT SIGNAL

SG No.	Signals
SG1	Sine wave with amplitude $0.5V_{P-P}$ ($f=100\text{ kHz}$, amplitude partially variable*) 
SG2	Sine wave with amplitude $0.1V_{P-P}$ ($f=100\text{ kHz}$, to 50 MHz)
SG3	Sine wave with amplitude $0.5V_{P-P}$ ($f=10\text{ MHz}$)
SG4	Sine wave with amplitude $0.5V_{P-P}$ ($f=50\text{ MHz}$)
SG5	Square wave with amplitude $0.5V_{P-P}$ ($f=1\text{ MHz}$, duty = 50%) 
SG6	Pulse with amplitude $2.0V_{P-P}$, and pulse width $3.0\ \mu\text{s}$ synchronous with the pedestal part of standard video stepped wave 
SG7	Pulse with amplitude $2.0V_{P-P}$ and pulse width $6.0\ \mu\text{s}$ synchronous with the blanking part of standard video stepped wave 
Standard video stepped wave	

* Refer to the NOTE.

M51387P

3-CHANNEL VIDEO AMPLIFIER FOR HIGH-RESOLUTION COLOR DISPLAY

TEST CIRCUIT 1

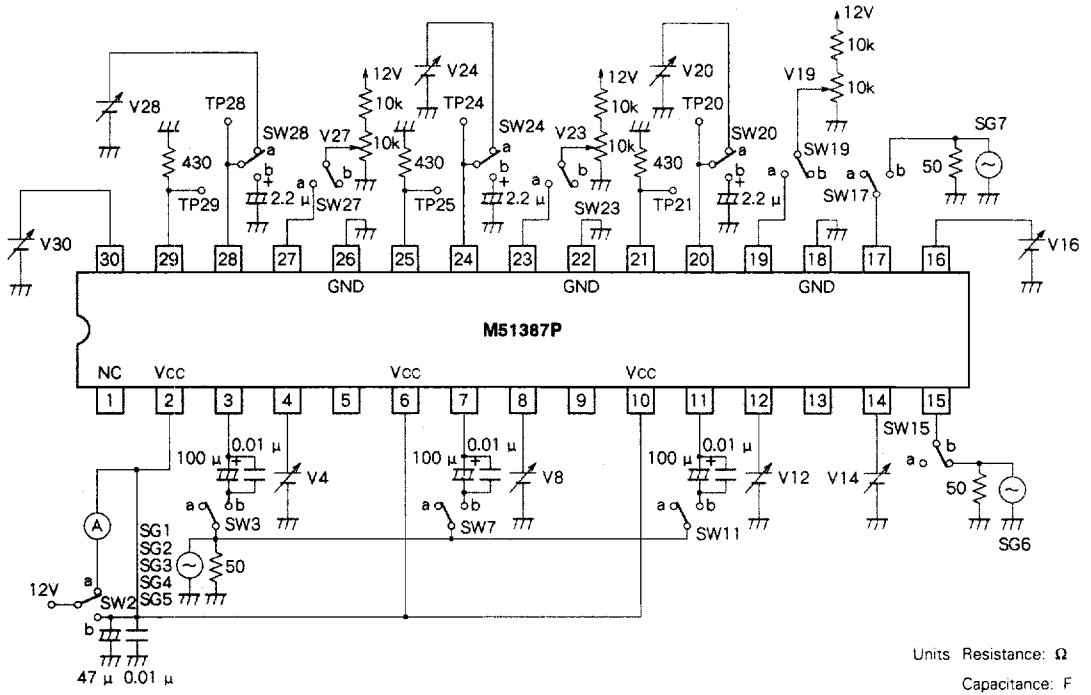

TEST CIRCUIT 2

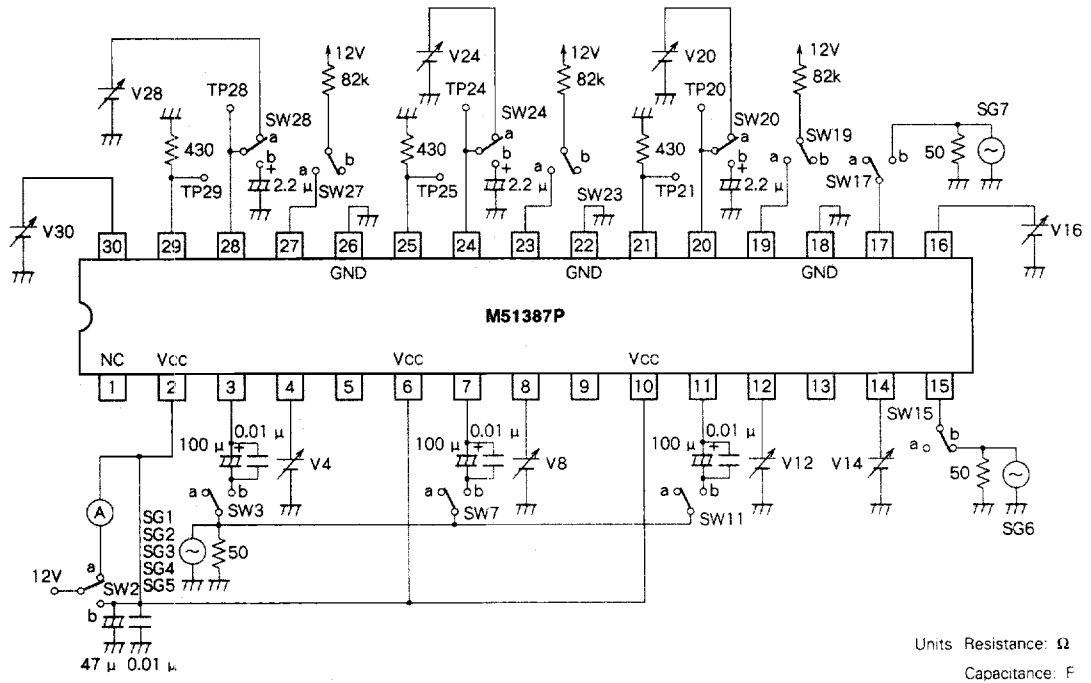

M51387P

3-CHANNEL VIDEO AMPLIFIER FOR HIGH-RESOLUTION COLOR DISPLAY

TYPICAL CHARACTERISTICS

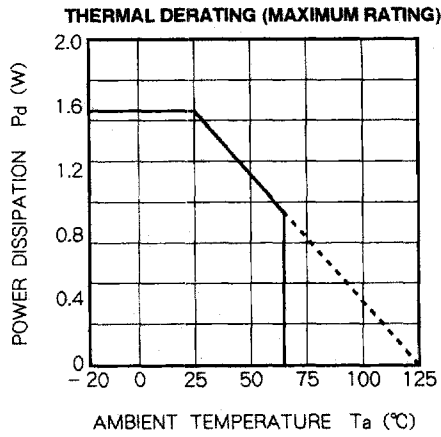

M51387P

3-CHANNEL VIDEO AMPLIFIER FOR HIGH-RESOLUTION COLOR DISPLAY

APPLICATION EXAMPLE

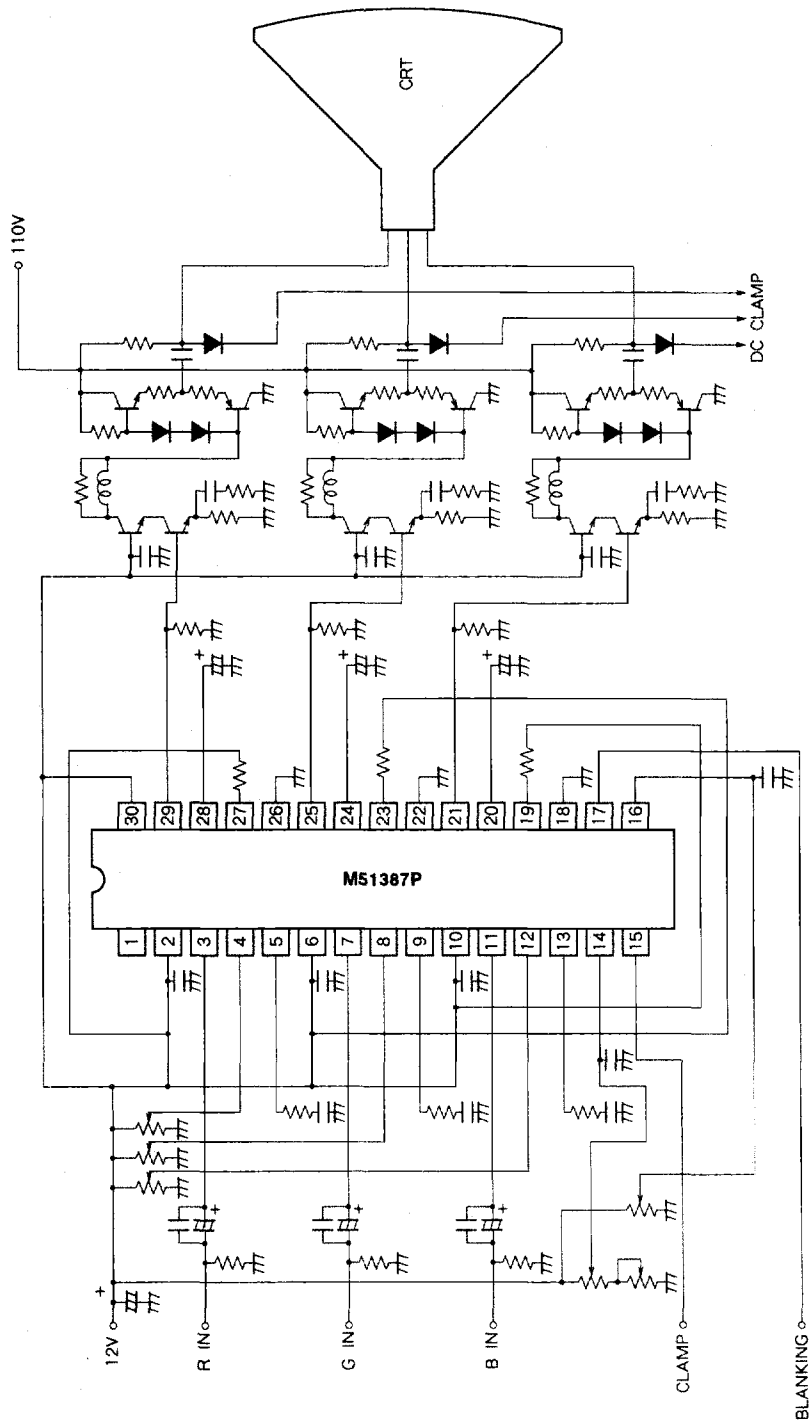

3-CHANNEL VIDEO AMPLIFIER FOR HIGH-RESOLUTION COLOR DISPLAY

DESCRIPTION OF PIN

Pin No.	Name	Voltage and wave information	Peripheral circuit of pins
①	NC	—	—
②	Vcc (Rch)	Vcc pin for Rch 12V	—
③	R IN	R signal input pin 3.8V	
④	R SUB CONTRAST	R-ch sub contrast control pin 4.0V	
⑤	R PEAKING	R-ch peaking pin Variable	
⑥	Vcc (Gch)	Vcc pin for Gch 12V	—
⑦	G IN	G signal input pin 3.8V	

3-CHANNEL VIDEO AMPLIFIER FOR HIGH-RESOLUTION COLOR DISPLAY

DESCRIPTION OF PIN (cont.)

Pin No.	Name	Voltage and wave information	Peripheral circuit of pins
⑧	G SUB CONTRAST	G-ch sub contrast control pin 4.0V	
⑨	G PEAKING	G-ch peaking pin Variable	
⑩	Vcc (Bch)	Vcc pin for Bch 12V	—
⑪	B IN	B signal input pin 3.8V	
⑫	B SUB CONTRAST	B-ch sub contrast control pin 4.0V	
⑬	B PEAKING	B-ch peaking pin Variable	

3-CHANNEL VIDEO AMPLIFIER FOR HIGH-RESOLUTION COLOR DISPLAY

DESCRIPTION OF PIN (cont.)

Pin No.	Name	Voltage and wave information	Peripheral circuit of pins
⑭	CONTRAST	Main contrast control pin 6.7V	
⑮	CLAMP PULSE	Clamping pulse input pin	
⑯	BRT	Main brightness control pin	
⑰	BLK PULSE	Blanking pulse input pin	
⑱	GND (Bch)	GND pin for Bch	—
⑲	B SUB BRT	B-ch sub brightness control pin Variable	

3-CHANNEL VIDEO AMPLIFIER FOR HIGH-RESOLUTION COLOR DISPLAY

DESCRIPTION OF PIN (cont.)

Pin No.	Name	Voltage and wave information	Peripheral circuit of pins
20	B HOLD	B-ch hold pin Variable	
21	B OUT	B-ch output pin Variable	
22	GND (Gch)	GND pin for Gch GND	—
23	G SUB BRT	G-ch sub brightness control pin Variable	
24	G HOLD	G-ch hold pin Variable	

3-CHANNEL VIDEO AMPLIFIER FOR HIGH-RESOLUTION COLOR DISPLAY

DESCRIPTION OF PIN (cont.)

Pin No.	Name	Voltage and wave information	Peripheral circuit of pins
25	G OUT	G-ch output pin Variable	
26	GND (Rch)	GND pin for Rch GND	
27	R SUB BRT	R-ch sub brightness control pin Variable	
28	R HOLD	R-ch hold pin Variable	
29	R OUT	R-ch output pin Variable	

M51387P

3-CHANNEL VIDEO AMPLIFIER FOR HIGH-RESOLUTION COLOR DISPLAY

DESCRIPTION OF PIN (cont.)

Pin No.	Name	Voltage and wave information	Peripheral circuit of pins
③①	WHITE PEAK	White peak clip pin	<p>The diagram shows a circuit for pin 30. It features a Vcc supply line at the top. A resistor, labeled with the pin number ③①, is connected between Vcc and the pin. Below the Vcc line, there are three vertical branches, each containing a 10.6k resistor connected to a common ground line at the bottom.</p>

3-CHANNEL VIDEO AMPLIFIER FOR HIGH-RESOLUTION COLOR DISPLAY

PRECAUTIONS FOR APPLICATION

1. Since this IC has very high frequency characteristics (peak at approximately $f=50\text{MHz}$) and oscillation readily occurs, do not attach any unnecessary capacitance to the peaking terminals (pins ⑤, ⑨, ⑬).
It is also effective to insert a series resistor to the output or peaking terminal. Further, note crosstalk as well.
2. The standard input for IC input (pins ③, ⑦, ⑪) is 1V_{P-P}.
3. When SUB CONTRAST is not used, connect each terminal (pins ④, ⑧, ⑫) to V_{cc} through $R=19\text{k}\Omega$, and use it in SUB CONTRAST FULL GAIN conditions.
4. Adjust the voltage with SUB BRIGHT so that the BRIGHT CONTROL (pin ⑯) voltage is used at 3V or more. (Due to the dynamic range of the pedestal-clamped circuit)
5. Note that the DC reproduction rate varies due to external impedance from the SUB BRIGHT pin. As an example for a method of not changing the DC reproduction rate, refer to the figure below.

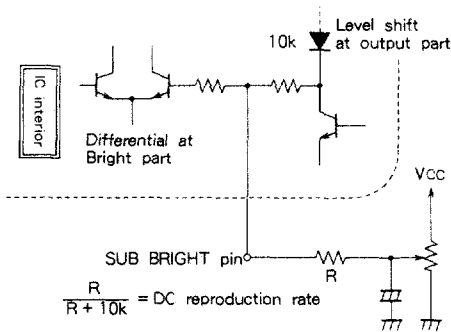

When SUB BRIGHT is not used, if each terminal (pins ⑯, ⑲, ⑳) is connected to V_{cc} through approx. 82kΩ, dispersion is reduced, and a proper operating voltage is produced. (DC reproduction rate: approx. 89%)

In this case, the three terminals cannot be connected in common.

6. If no adjustment is made with SUB CONTRAST and SUB BRIGHT, carry out unit design which accounts for IC dispersion.
7. Note that the clamping level varies due to the positional relation between the clamping pulse and blanking pulse.
To determine the specified value, the clamping pulse and blanking pulse should be independent with no intersection. (Refer to the input signal.)

8. Power dissipation is $I_{CC} + V_{CC} = 77(\text{mA}) + 12(\text{V}) = 924(\text{mW})$. The power dissipated by load resistance, if the output DC voltage is set at 2.4V, is:

$$\frac{2.4(\text{V})}{0.43(\text{k}\Omega)} = 2.4\text{V} \times 3 = 40(\text{mW})$$

Accordingly, 884(mW) is the power dissipated inside the IC. In order to reduce power dissipation, make load resistance greater than 430Ω.

9. Caution in Temperature Characteristics
Note that the temperature characteristics change due to the setting voltage at the output tip level shift part and SUB BRIGHT part.
The SUB BRIGHT connection method is as follows, for example:

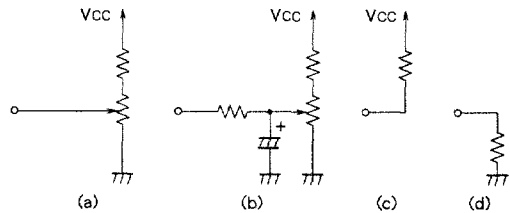

The data described in the delivery specifications is obtained as per (c) above. However, the method (d) above is rather hard to use due to the relation of DC dynamic range in the SUB BRIGHT circuit section; therefore, check the operation in applications.

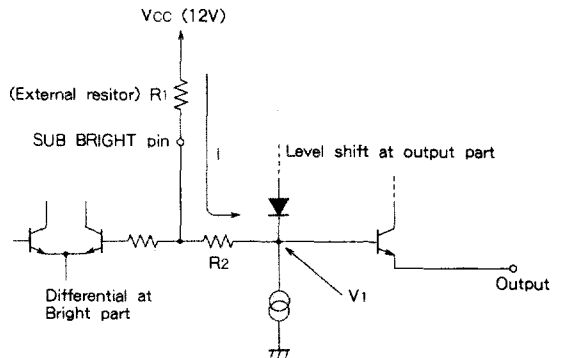

If Fig. (c) is taken, for example, the above circuit is obtained, and V₁ is determined by:

$$V_1 = V_{CC} - R_1 I - R_2 I$$

Thus, it is found that the temperature characteristics depend on "−R₂".

In Fig. (d), $V_1' = R_1 I' + R_2 I'$ as follows:

3-CHANNEL VIDEO AMPLIFIER FOR HIGH-RESOLUTION COLOR DISPLAY

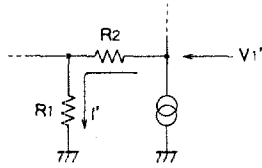

It follows that the temperature characteristics depend on "R2."

As another example, when V_1 and SUB BRIGHT voltage is set to an equal value (for example, 3.0V), the current I does not flow, and R2 temperature characteristics can be ignored.

In this case, the temperature characteristics depend on only V_{be} of T_r at the output end.