

# M52472P

## 4-INPUT 3-CHANNEL ANALOG SWITCH

### DESCRIPTION

The M52472P is a semiconductor integrated circuit containing analog switches designed for use in a video system. It contains two audio switches and one video switch. Each switch has four inputs and can be simultaneously controlled. In addition, the video switch contains an amplifier with gain of about 7.0 dB.

### FEATURES

- Video and stereo sound switches in one package
- Wide frequency range(video switch)..... DC~10MHz
- High separation(video)..... Crosstalk 60dB(typ.)(@5MHz)

### APPLICATION

Video equipment.

### RECOMMENDED OPERATING CONDITION

Supply voltage range.....5~14V

### PIN CONFIGURATION (TOP VIEW)

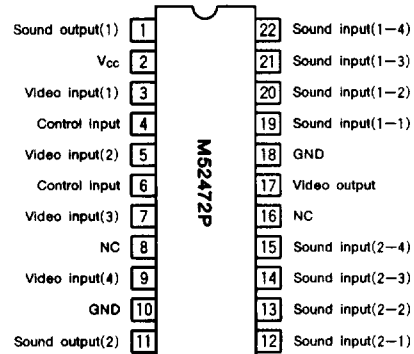

Outline 22P4

NC : NO CONNECTION

### BLOCK DIAGRAM

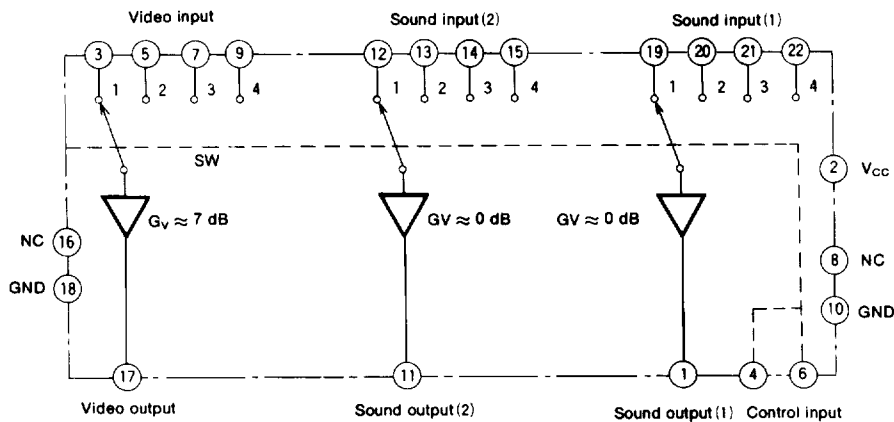

**4-INPUT 3-CHANNEL ANALOG SWITCH**

**ABSOLUTE MAXIMUM RATINGS**

Symbol	Parameter	Rating	Unit
V <sub>CC</sub>	Supply voltage	14	V
V <sub>IC</sub>	Control voltage	0~V <sub>CC</sub>	V
P <sub>d</sub>	Power dissipation	1.6	W
T <sub>opr</sub>	Operating temperature	-20~75	°C
T <sub>stg</sub>	Storage temperature	-40~125	°C

**ELECTRICAL CHARACTERISTICS** (T<sub>a</sub>=25°C, V<sub>CC</sub>=12V, unless otherwise noted)

Symbol	Parameter	Test conditions	Limits			Unit
			Min.	Typ.	Max.	
I <sub>CC</sub>	Circuit current		—	21	30	mA
V <sub>IC</sub>	Input bias voltage	Sound	5.8	6.5	7.2	V
		Video	4.0	4.4	4.8	
V <sub>ODC</sub>	Output bias voltage	Sound	5.2	5.8	6.4	V
		Video	5.0	5.5	6.0	
V <sub>OP</sub>	Output pedestal		—	5.0	100	mV
V <sub>TH</sub>	Threshold voltage		2.3	2.5	2.7	V
G <sub>v</sub>	Voltage gain	Sound f=1kHz V <sub>IN</sub> =1V <sub>rms</sub>	-0.5	-0.1	—	dB
		Video f=1MHz V <sub>IN</sub> =0.5V <sub>rms</sub>	6.0	7.0	8.0	
THD	Total harmonic distortion	f=1kHz V <sub>OUT</sub> =1V <sub>rms</sub>	—	0.01	0.2	%
V <sub>N</sub>	Output noise voltage	Sound R <sub>g</sub> =620Ω BW=15kHz	—	3.0	50	μV <sub>rms</sub>
		Video R <sub>g</sub> =75Ω BW=10MHz	—	0.5	1.0	
CT	Crosstalk	Sound f=1kHz V <sub>IN</sub> =1V <sub>rms</sub>	80	95	—	dB
		Video f=5MHz V <sub>IN</sub> =0.5V <sub>rms</sub>	50	60	—	
I <sub>IN</sub>	Control input current		-20	-2.0	1.0	μA
Z <sub>IN</sub>	Input impedance	Sound f=1kHz 20kHz	47	58	—	kΩ
		Video f=100kHz	16	26	—	

**SWITCH MODE VERSUS CONTROL INPUT**

SW	④ PIN	⑥ PIN
1	GND	GND
2	GND	V <sub>CC</sub>
3	V <sub>CC</sub>	GND
4	V <sub>CC</sub>	V <sub>CC</sub>

**4-INPUT 3-CHANNEL ANALOG SWITCH**

**TEST CIRCUIT** (Ta=25°C, Vcc=12V, unless otherwise noted)

**CIRCUIT CURRENT      INPUT BIAS VOLTAGE      OUTPUT BIAS VOLTAGE**

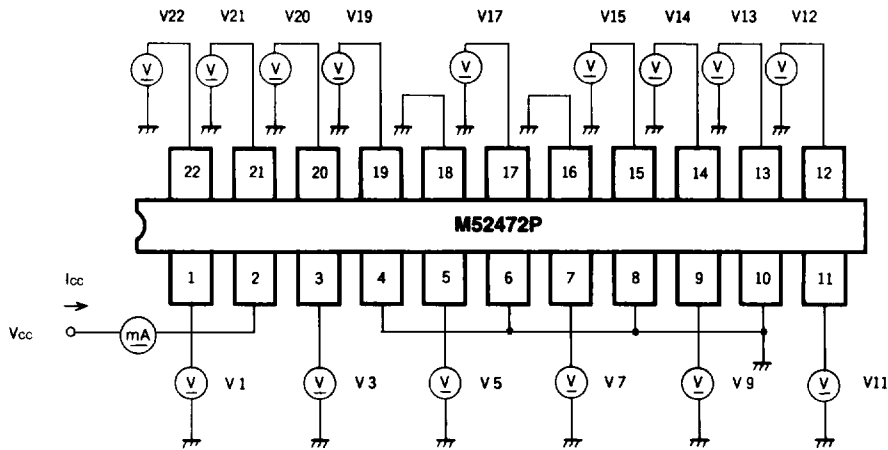

**OUTPUT DC OFFSET VOLTAGE**

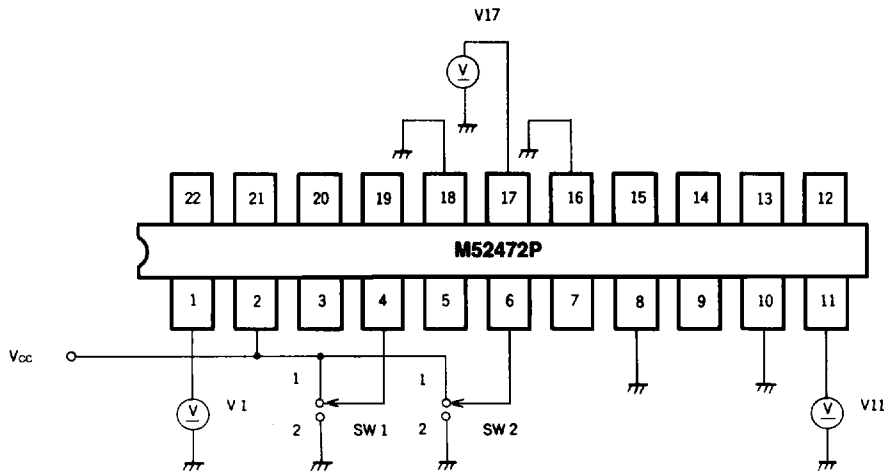

For video: Measure DC voltage at V17 when SW2 is turned to 1 and 2 respectively with SW1 turned to 1 and also when SW2 is turned to 1 and 2 respectively with SW1 turned to 2.

For sound: Measure DC voltage at V1 and V11 when SW2 is turned to 1 and 2 respectively with SW1 turned to 1 and also when SW2 is turned to 1 and 2 respectively with SW1 turned to 2.

$$V_{OP} = V_{max} - V_{min}$$

4-INPUT 3-CHANNEL ANALOG SWITCH

CONTROL PIN THRESHOLD VOLTAGE

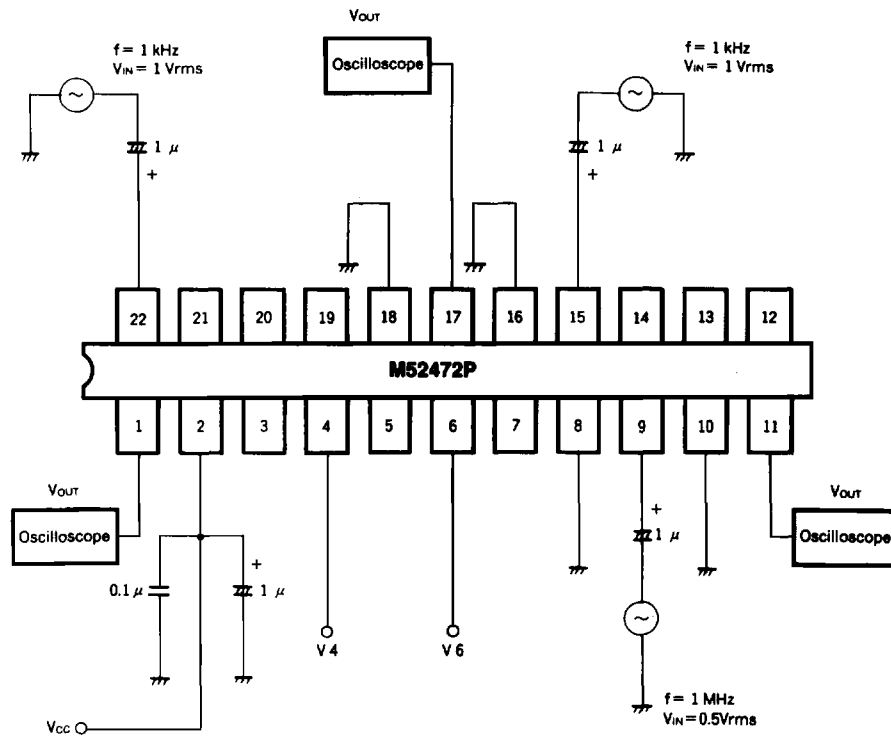

Value of V6 (V4) where DC voltage of V4 (V6) is Vcc, and when the AC element of each output pin switches from OFF to ON while V6 (V4) increases from 1 to 4 [V]

4-INPUT 3-CHANNEL ANALOG SWITCH

VOLTAGE GAIN, CROSSTALK, TOTAL HARMONIC DISTORTION

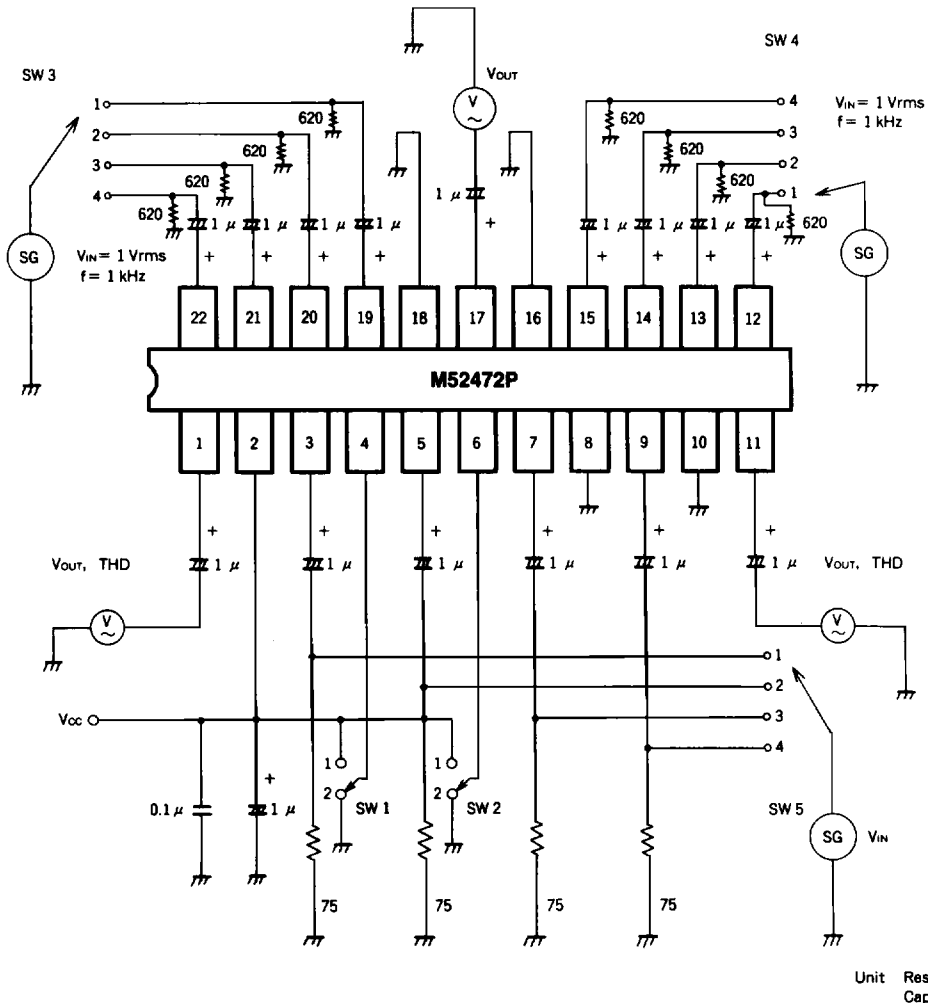

Unit Resistance : Ω  
Capacitance : F

FOR VIDEO

SW1	SW2	SW5	17PIN
2	2	1	Vos
		2, 3, 4	Voc
2	1	2	Vos
		1, 3, 4	Voc
1	2	3	Vos
		1, 2, 4	Voc
1	1	4	Vos
		1, 2, 3	Voc

FOR SOUND (1)

SW1	SW2	SW3	1PIN
2	2	1	Vos, THD
		2, 3, 4	Voc
2	1	2	Vos, THD
		1, 3, 4	Voc
1	2	3	Vos, THD
		1, 2, 4	Voc
1	1	4	Vos, THD
		1, 2, 3	Voc

FOR SOUND (2)

SW1	SW2	SW4	11PIN
2	2	1	Vos, THD
		2, 3, 4	Voc
2	1	2	Vos, THD
		1, 3, 4	Voc
1	2	3	Vos, THD
		1, 2, 4	Voc
1	1	4	Vos, THD
		1, 2, 3	Voc

Crosstalk CT = 20LOG (Vos/Voc) dB  
Voltage gain Gv = 20LOG (Vos/VIN) dB



**4-INPUT 3-CHANNEL ANALOG SWITCH**

**OUTPUT NOISE VOLTAGE**

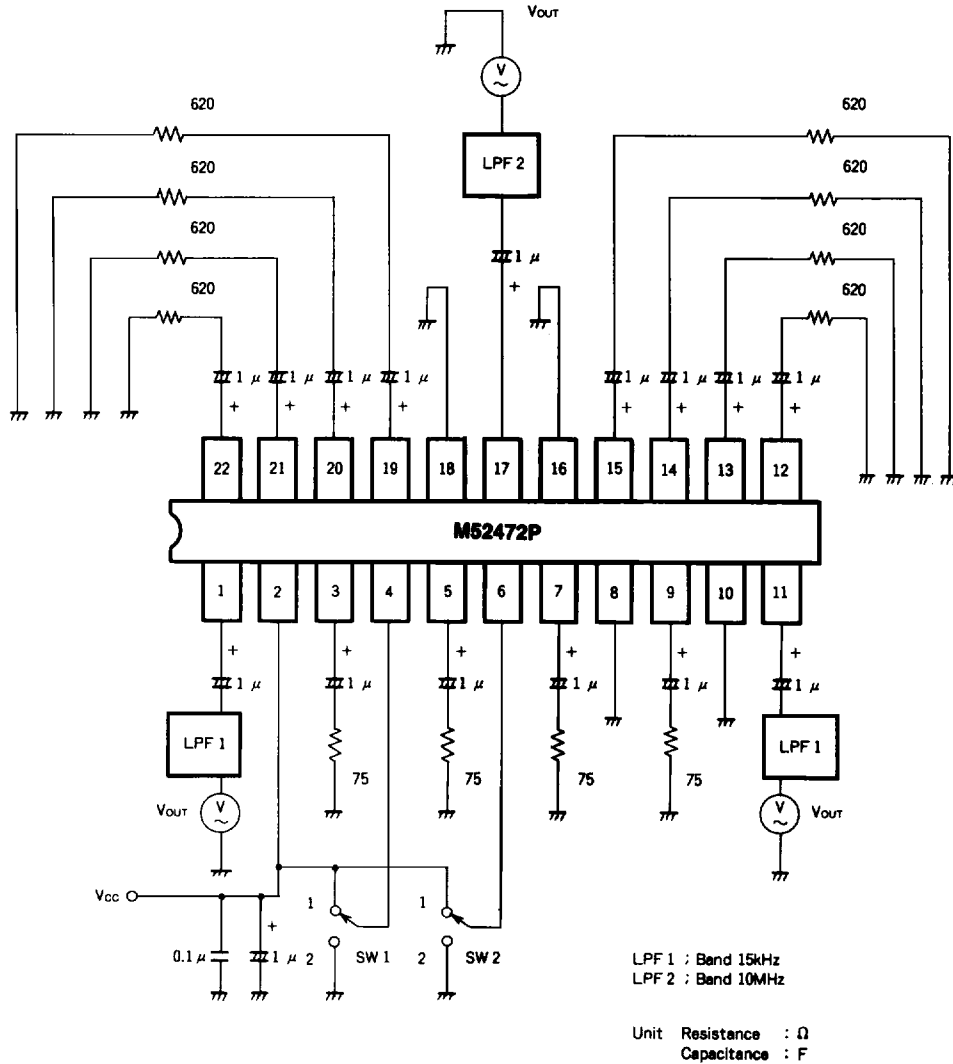

**4-INPUT 3-CHANNEL ANALOG SWITCH**

**CONTROL PIN INPUT CURRENT**

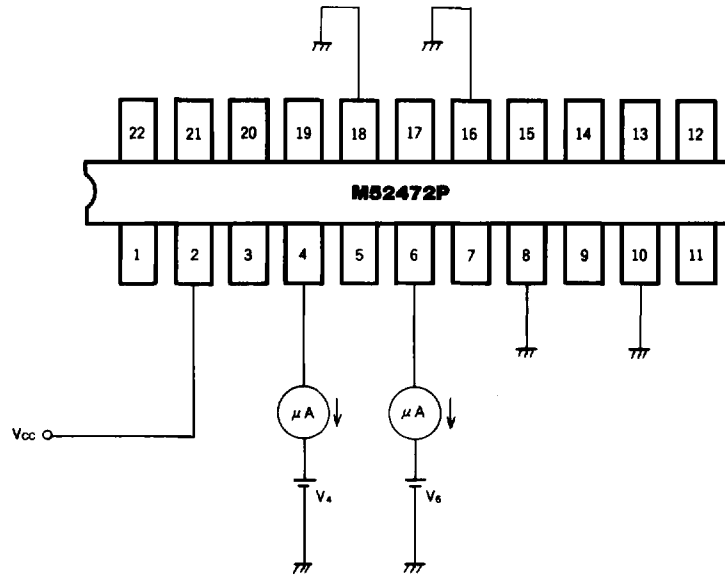

Currents  $I_{\mu A4}$ ,  $I_{\mu A6}$  respectively through pins 4 and 6 when DC voltages  $V_4$ ,  $V_6$  (0 to 14 V) are applied.

**4-INPUT 3-CHANNEL ANALOG SWITCH**

**TYPICAL CHARACTERISTICS**

**THERMAL DERATING (MAXIMUM RATING)**

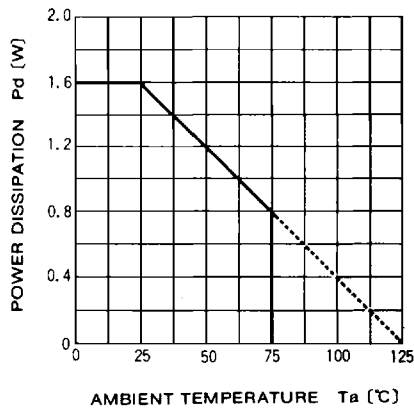

**CROSSTALK VS. FREQUENCY (SOUND)**

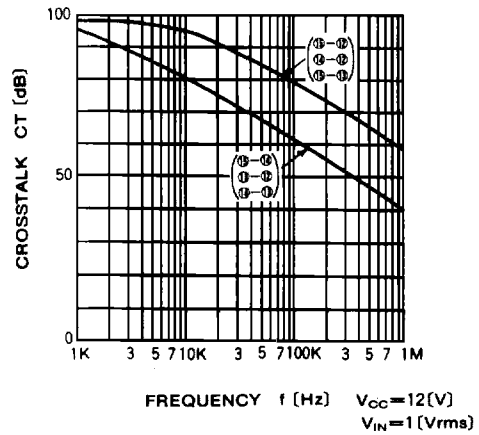

**CIRCUIT CURRENT VS. SUPPLY VOLTAGE**

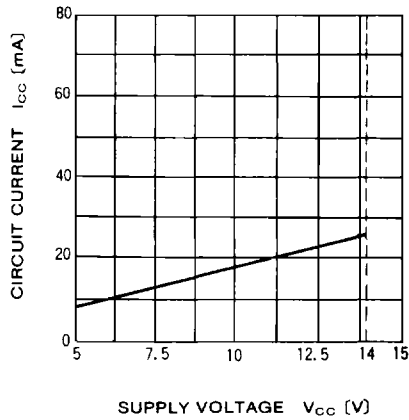

**TOTAL HARMONIC DISTORTION VS. OUTPUT VOLTAGE (SOUND)**

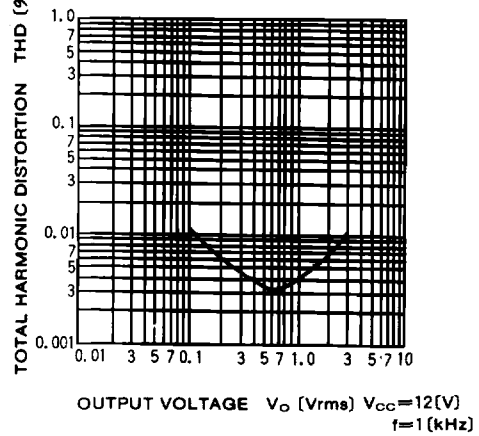

**VOLTAGE GAIN VS. FREQUENCY (SOUND)**

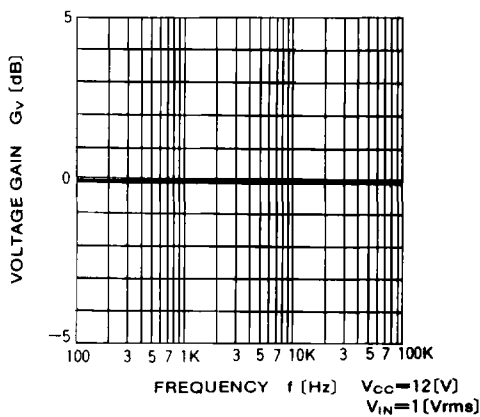

**OUTPUT NOISE VOLTAGE VS. SIGNAL SOURCE RESISTANCE (SOUND)**

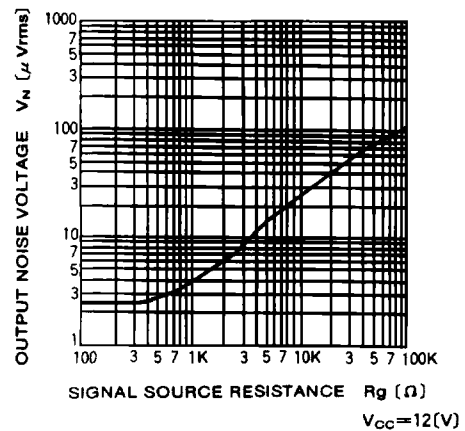



4-INPUT 3-CHANNEL ANALOG SWITCH

TOTAL HARMONIC DISTORTION VS. FREQUENCY (SOUND)

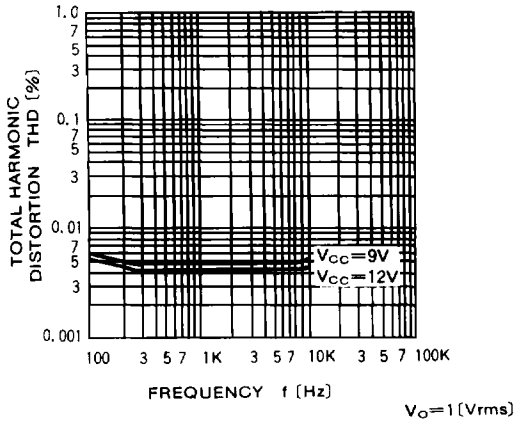

OUTPUT DC VOLTAGE VS. INPUT DC VOLTAGE (SOUND)

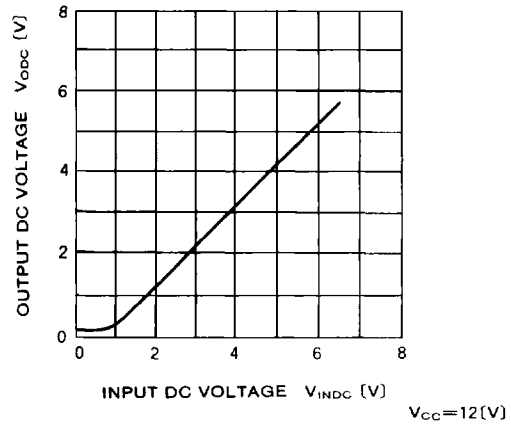

VOLTAGE GAIN VS. FREQUENCY (VIDEO)

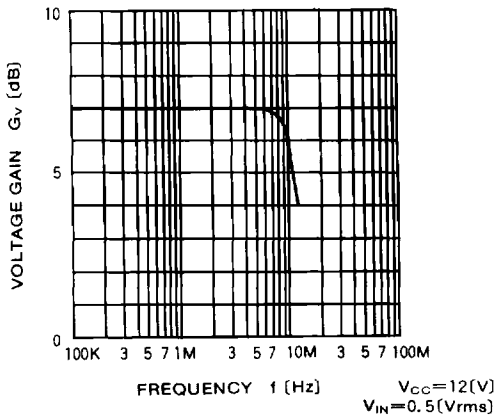

TOTAL HARMONIC DISTORTION VS. OUTPUT VOLTAGE (VIDEO)

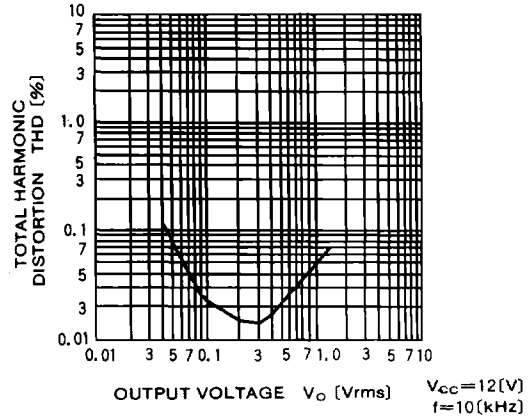

CROSSTALK VS. FREQUENCY (VIDEO)

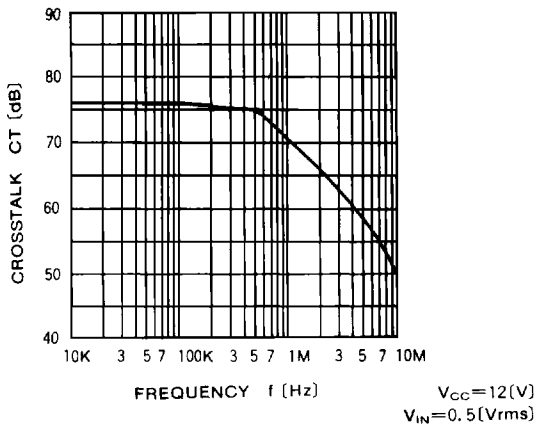

OUTPUT DC VOLTAGE VS. INPUT DC VOLTAGE (VIDEO)

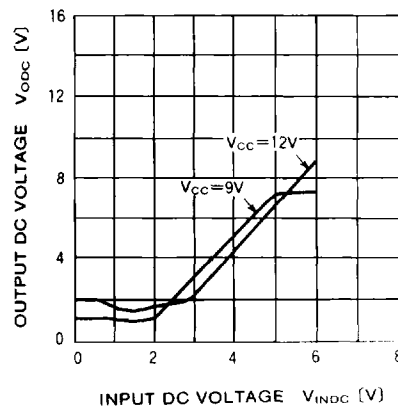

**4-INPUT 3-CHANNEL ANALOG SWITCH**

**APPLICATION EXAMPLE**

