

Outline

M62256FP is a semiconductor integrated circuit designed to control the battery charger. This IC controls not only all the time sequence needed for battery charging, but also gives full support for detection of battery temperature, protection over current and voltage, and safety timer, etc. It is also a simple matter to charge Ni-Cd, Ni-MH batteries by adding a small peripheral components to this IC. This IC has a feedback controlling of the charge current and the output voltage.

Features

- Designed for low voltage(3V)operation.
- Built-in CR oscillator is used for internal logic.
- Built-in initialization timer and safety timer enable - V error detection and over-charging.
- Built-in D/A converter and shift-resister circuits to maintain the peak voltage of battery.
- Built-in Main output SW and discharge drive circuits.
- Built-in LED drive circuits for displaying the status of the power supply and charging/discharging.
- Built-in System Reset circuit for detecting the power supply voltage.
- Built-in temperature detection circuit for the Ni-MH battery
- Built-in voltage and current control circuit which enables feedback to the primary side of the SMPS.
- Built-in protective functions including detection of over-voltage in charge mode and over-current in adapter mode, and others.

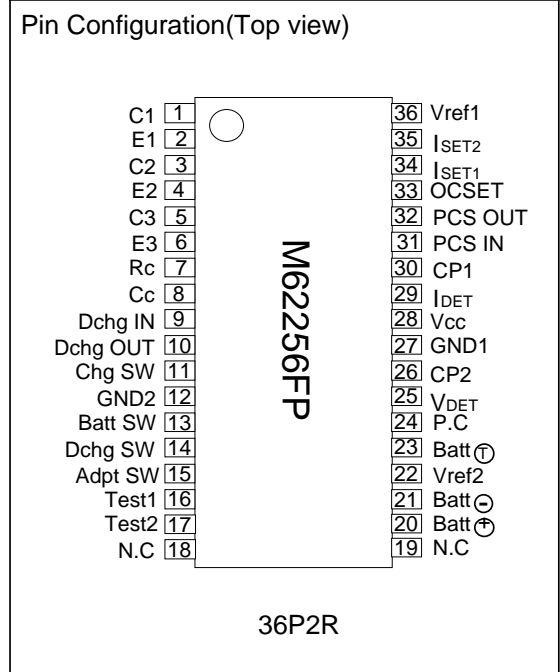

Uses

General electronic battery charger for VCR and camera in one unit, handheld telephones, etc.

Block diagram

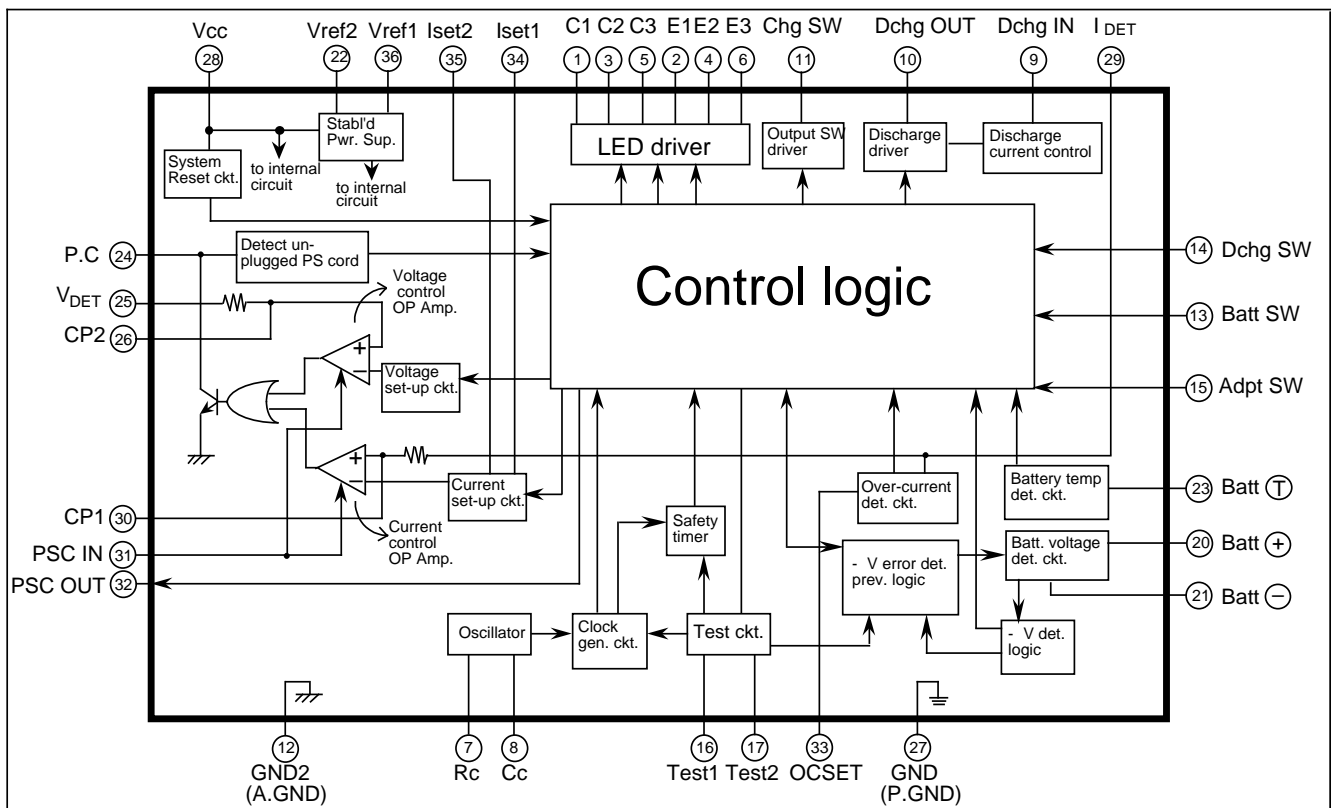

Functions of Terminal Explained

Terminal No.	Symbols	Functions
1, 3, 5	C1,C2,C3	LED drive terminals (Open collector outputs)
2, 4, 6	E1,E2,E3	These terminals are used to set the LED drive currents.
7, 8	Rc, Cc	These terminals are used to set the oscillating frequency of the internal clocks.
9	Dchg IN	This is an input terminal used to detect the current which is used for the discharge current feedback.
10	Dchg OUT	This is the drive terminal for the transistor mounted externally for discharge purposes.
11	Chg SW	This is the SW drive terminal used for charging battery.
27, 12	GND1, 2	These are grounding terminals. (GND1 is for logic and GND2 is for analog.)
13	Batt SW	This is used to detect mounting of battery.(It is pulled up internally)
14	Dchg SW	This is used to detect the discharge SW.(It is pulled up internally)
15	Adpt SW	This is used to detect adapter SW.(It is pulled up internally)
16, 17	Test1, 2	These are Test Mode set-up terminal.(It is pulled up internally)
20	Batt +	This terminal is connected to the + terminal of the battery.
21	Batt -	This terminal is connected to the - terminal of the battery.
23	Batt T	This terminal is connected to the temperature detecting terminal of the battery.
22	Vref2	This is the voltage reference terminal for temperature detection.
24	P.C	This terminal is connected to the photo-coupler used for feedback.
25	V _{DET}	This terminal is used to monitor the output voltage.
26, 30	CP1, CP2	This terminal is used to make connection with capacitor(s) and resistor(s) which are used for phase compensation.
29	I _{DET}	This terminal is used to detect the charging current or output current.
31	PCS IN	This is an input terminal used for photo-coupler short.
32	PCS OUT	This terminal goes "H" when over-current is detected.
33	OC SET	This terminal is used to set the over-current detection value when the adapter mode is used.
34, 35	Iset1, 2	These are used to set the charging current.(Iset1 is for quick charge and Iset2 is for the trickle charge.)
36	Vref1	This terminal is sets the standard voltage for over-current set-up value and the charge current set-up.

Absolute Maximum Ratings (Ta=25°C unless specified otherwise)

Items	Symbols	Condition	Ratings	Unit
Power supply voltage	Vcc		16	V
Chgon terminal drive current	IChgon		50	mA
Dchgout terminal drive current	IDchg		-5	mA
LED drive current	IC1-C3		20	mA
P.C drive current	IP.C		5	mA
Vref1 output current	Iref1		-1	mA
Vref2 output current	Iref2		-1	mA
Power dissipation	Pd		650	mW
Thermal derating ratio	K θ	Ta=25°C	6.5	mW/°C
Operating temperature	Topr	Ta>25°C	-20~+75	°C
Storage temperature	Tstg		-40~+125	°C

(Notes)

Polarity of current:

The direction of current flowing into the IC is considered positive(+).

The direction of current flowing out of the IC is considered negative(-).

The voltage impressed on the open collector output terminal should be the absolute maximum voltage of the power supply.

The voltage difference between the negative terminal of the battery and the GND terminal should be 0V~0.6V.

Electrical Characteristics (V_{CC}=7V, T_a=25°C unless specified otherwise)

All device

Items	Symbols	Conditions	Standard			Unit
			Min	Typ	Max	
Power supply voltage	V _{CC}		3.0		15.0	V
Circuit current	I _{CC}	V _{CC} =7V when quick charge	18.0	27.0	40.0	mA
Power supply detecting voltage	V _{THV_{CC}}		2.66	2.80	2.94	V

Reference

Items	Symbols	Conditions	Standard			Unit
			Min	Typ	Max	
V _{ref1} output voltage	V _{ref1}	I _{ref1} =150uA	1.18	1.25	1.32	V
V _{ref2} output voltage	V _{ref2}	I _{ref2} =350uA	1.70	1.80	1.90	V

Items	Symbols	Conditions	Standard			Unit
			Min	Typ	Max	
OCSET terminal flow out current	I _{OCSET}	OCSET=220mV	-1			uA
ISET1 terminal flow out current 1	I _{SET1-1}	Excluding charging time	30	50	85	uA
ISET1 terminal flow out current 2	I _{SET1-2}	When charging	-1			uA
ISET2 terminal flow out current 1	I _{SET2-1}	Excluding trickle charging time	30	50	85	uA
ISET2 terminal flow out current 2	I _{SET2-2}	When trickle charging	-1			uA

Driver

Items	Symbols	Conditions	Standard			Unit
			Min	Typ	Max	
Chgon terminal output L voltage	V _{satChg}	I _{Chgon} =50mA	—	0.3	0.6	V
Dchgout terminal H voltage	V _{OH} Dchg	I _{Dchgout} =5mA, V _{CC} =7V	—	5.2	6.0	V
LED output L voltage	V _{sat LED}	I _{LED} =5mA	—	0.3	0.6	V
DchgIN terminal detecting voltage	V _{DchgIN}		0.5	0.8	1.2	V

Control Section

Items	Symbols	Conditions	Standard			Unit
			Min	Typ	Max	
Range of input voltage	V _{IN}		0		V _{CC}	V
Input bias current	I _{Bias}		-1			uA
P.C output L voltage	V _{PCL}	I _{PC} =2mA	—	0.2	0.5	V
PCS OUT terminal flow out current	I _{PCSOUT}		-18	-10	-5	uA
PCS IN terminal threshold voltage	V _{THPCSIN}	When over-current is detected	0.5	0.8	1.2	V

Each SW Detection Terminal

Items	Symbols	Conditions	Standard			Unit
			Min	Typ	Max	
Batt SW terminal flow out current	I _{BattSW}	V _{CC} =7V, V _{BattSW} =0V	-240	-140	-80	uA
Batt SW terminal threshold voltage	V _{THBatt}	V _{CC} =7V	3.0	5.6	6.0	V
Dchg SW terminal flow out current	I _{DchgSW}	V _{CC} =7V, V _{DchgSW} =0V	-240	-140	-80	uA
Dchg SW terminal threshold voltage	V _{THDchg}	V _{CC} =7V	3.0	5.6	6.0	V
Adpt SW terminal flow out current	I _{AdptSW}	V _{CC} =7V, V _{AdptSW} =0V	-240	-140	-80	uA
Adpt SW terminal threshold voltage	V _{THAdpt}	V _{CC} =7V	3.0	5.6	6.0	V

Internal Voltage Set-up

Items	Symbols	Conditions	Standard			Unit
			Min	Typ	Max	
Set-up output voltage at Adpt mode	V _{Adpt}		820	864	910	mV
Set-up output voltage at charge mode	V _{CHG}		1.19	1.26	1.33	V
Set-up output voltage when over-current is detected	V _{DOWN}		478	504	530	mV
ISET1set-up voltage	V _{ISET1}	When quick charging	123	130	137	mV
ISET2set-up voltage	V _{ISET2}	When trickle charging	11.4	12.0	12.6	mV
OCSET set-up voltage	V _{OCSET}	When adapter mode	208	220	232	mV
Over-voltage set-up voltage	V _{OV}		9.0	9.5	10	V
- V detection voltage1	V- V-1	within Initialization timer	0.6	1.0	1.4	V
- V detection voltage2	V- V-2	after initialization timer has passed	60	100	140	mV
Voltage at the end of discharge	V _{CHGON}		4.7	5.0	5.3	V
Temperature detection set-up voltage1	V _{TTH1}	Temperature at the start of charging	0.92	0.97	1.02	V
Temperature detection set-up voltage2	V _{TTH2}	Temperature at the start of recharging	1.06	1.12	1.18	V
Over-heating detection set-up voltage	V _{O/H}	Charge stop temperature	0.81	0.86	0.91	V

Items	Symbols	Conditions	Standard			Unit
			Min	Typ	Max	
Oscillation frequency	f _{osc}	R _c =30KΩ , C _c =2200pF	9.22	10.24	11.26	KHz
Initialization timer1	T _{m1}	Battery voltage<5V	18.0	20.0	22.0	min
Initialization timer2	T _{m2}	5V Battery voltage<6.5V	4.5	5.0	5.5	min
Initialization timer3	T _{m3}	Battery voltage 6.5V	2.7	3.0	3.3	min
Undetected time for -ÉçV	T _{NDET}		2.7	3.0	3.3	min
Safety timer1	T _{ms1}	when quick charging	2.7	3.0	3.3	hr
Safety timer2	T _{ms2}	when trickle charging	21.6	24	26.4	hr
Over-current detection time	T _{OC}		9.0	10.0	11.0	sec

Note: The time given to each timer is when the oscillation frequency of 10.24KHz is used.

Recommended Operating Range

Power supply voltage (V _{cc})	3~15V
Charge current (See Note1)		
Preliminary charge	50~200mA
Quick charge	0.8~2A
Trickle charge	80~200mA
Discharge current (See Note1)	300~500mA
LED drive current (See Note2)	115mA

Note1. The charging current must be set according to the battery specifications.

The currents used for quick charge and trickle charge are determined by the voltage of the terminals Iset1 and Iset2 and current sense resistor R4 (Application in page 9).

Note2. The LED drive current is calculated by the following equation.

$$I_{LED} \cong \frac{200mV}{R_L} (A)$$

FUNCTION DESCRIPTION

1. Charging Operation

(1) Detection of Battery

When the Batt SW terminal shows "L", it indicates that the battery is installed

(2) Conditions for Quick Charge

As soon as the battery is installed, its voltage and temperature are detected. If the battery voltage is below 5V, the preliminary charging mode starts. When the battery voltage exceeds 5V, the quick charge commences.

On the other hand, if the battery voltage exceeds 5V, the following will take place. If the battery temperature is less than 55°C, the quick charge will take place. If it is higher than 55°C, the preliminary charge mode will continue until the temperature falls below 55°C. The charge current used for the quick charge is set by Iset1.

(3) Initialization timer

The initialization timer is set according to Table1. The - V is not detected for 3 minutes. Detection of - V within the initialization timer is set to 1V to prevent erroneous detection of - V during the initial charging.

Table1 Setting up the initialization timer

The initial battery voltage	Time of initialization timer
Less than 5V	20min.
More than 5V but less than 6.5V	5min.
6.5V or more	3min.

(4) Charge control

When the initialization timer completes its function, detection of - V is set to 100mV and the peak voltage of the battery held inside is compared against the battery voltage detected. After - V is detected, the trickle charge starts at the current set by Iset2.

(5) Safety Timer

The Safety Timer controls the charging time. The quick charging time stops 3 hours and the trickle charging time ends after 24 hours.

(6) Protective functions

- (a) Over-voltage detection Charging stops when the battery voltage goes to 9.5V or higher.
- (b) Over-heat detection Charging stops when the battery temperature becomes 63°C or higher. When the temperature goes to 45°C or lower, it recharges once.
- (c) Power supply voltage detection When the power supply voltage goes below 2.8V, the initial reset takes place.
- (d) Unplugged power supply cord ... When the unplugged power supply cord is detected, the output SW is turned off.

(7) Applicable batteries

Ni-Cd battery, Ni-MH(nickel-metalhydrogen) battery (T/ t, V taper can not be detected.)

2. Adapter Mode Operation

(1) Adapter Mode

The adapter mode (Adapter standby mode) goes into effect when both the battery and the adapter are not connected. The fixed voltage mode (7.2V) is set.

(2) Detection of Adapter

Adpt SW is used for detection of Adapter. When this terminal goes "H", Adapter is judged to be present. If Adapter is connected during charging, charging is discontinued and the Adapter Mode goes into effect. (The Adapter Mode has priority.)

(3) Setting Up the Output Voltage

The output voltage at the time of the Adapter Mode is set the internally set 7.2V.

(4) Protection Function

The over-current protection function is the only one protective function active during the Adapter Mode. The current value is set by the voltage at the OCSET terminal. When the over-current is detected, the output is controlled as shown in the following flow chart, The RESET will take place when Adpt SW terminal goes "L".

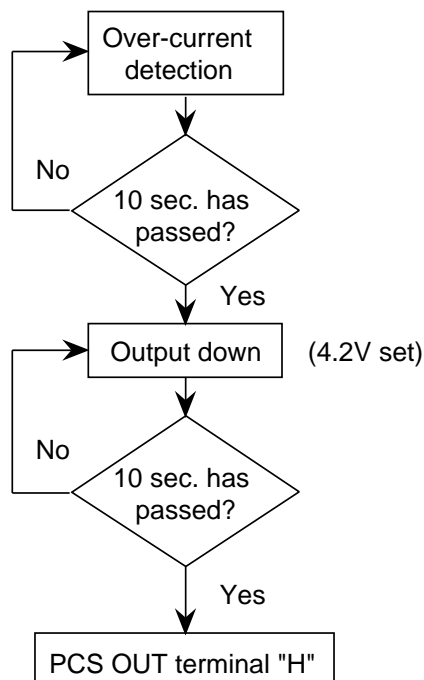

3. Discharge Operation

(1) Discharge Control

The Dchg SW terminal is used for the forced discharge of the battery. Discharge starts when this terminal stays "L" 0.7seconds or more. The Dchg IN terminal and the Dchg OUT terminal are used to control discharge. These terminal contain the feedback function which enables constant current discharge.

(2) Detection of Adapter

When the voltage of the battery which has been discharging reaches 5V or less, the discharge Mode has canceled. (Charging Mode takes over.)

(3) Forced Ending of Discharge

Once the discharge mode is in progress, it is possible to cancel the discharge mode by making the Dchg SW terminal to "L" once more. (Stays 0.7 seconds or more.)

(4) RESET Operation

The RESET circuit goes into operation when the power supply voltage goes 2.8V(typ) or lower. The internal logic circuit are all RESET to the initial states.

(5) Modes Setting

The Adapter Mode has the highest priority. Modes are switched in the following.

(a) When the power is turned ON

Power ON puts the Adapter Mode in Standby

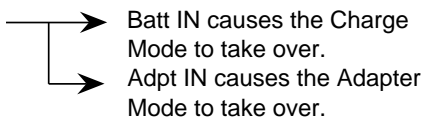

(b) When the battery is connected ...

- * Quick charge Adpt IN causes the Adapter Mode to take over. Adpt IN causes the initial RESET to start and the Adapter Mode goes into operation. Adpt OUT starts the Charging Mode by way of the initial check.
- * Trickle charge Adpt IN sets the Charge OFF and the Adapter Mode takes over. The Charge OFF Mode continues after Adpter OUT.
- * Charge OFF Adpt IN causes temporary stop. Then, the Adapter Mode takes over.
- * Charge standby (Preliminary charge) Continues after Adpt OUT

(c) When the battery is disconnected during the Adapter is in operation

Adpt IN → Batt OUT → Adpt OUT → Adapter Mode standby
 Adpt IN → Batt OUT → Batt IN → Adpt OUT

→ : It is assumed that a different battery connected and the Charge Mode starts by way of the initial check.

M62256FP

Single chip battery charger control IC

Application example M62256FP

