

PCM REMOTE CONTROL TRANSMITTERS

- M709 : 40 COMMANDS x 16 ADDRESSES
- M710 : 64 COMMANDS x 16 ADDRESSES
- ADDRESS ORGANIZATION PROVIDES WIDE RANGE OF SIMULTANEOUS APPLICATIONS WITHOUT INTERFERENCE BETWEEN SYSTEMS
- IMPROVED PCM TRANSMISSION CODE PROVIDES EASY RECOGNITION OF FALSE SIGNALS
- "FLASH" OR "CARRIER" PIN SELECTABLE TRANSMISSION MODES
- END OF TRANSMISSION CODE
- SINGLE CONTACT MATRIX KEYBOARD
- INTEGRATED ANTIBOUNCE AND INTERLOCK
- WIDE SUPPLY RANGE (M709 - M710 4.5 to 10.5V) / (M709A - M710A 3 to 10.5V)
- WIDE REFERENCE FREQUENCY RANGE (445 to 510kHz ceramic resonator)
- VERY LOW POWER CONSUMPTION DURING TRANSMISSION. OUTPUT DUTY CYCLE 0.15% (flash mode), 0.7% (carrier mode)
- FULLY COMPATIBLE WITH M491 AND M494 (In flash mode)

DESCRIPTION

These ICs have been developed for remote control in consumer applications (TV, radio, video recorders) or in the industrial field and use a highly reliable transmission code which has a capacity of 1024 channels. Each transmitted word is structured into 4 bits which constitute the address and 6 bits which constitute the command (64 commands available). One command (1st = 000000) is used to transmit the "end of transmission code" when the key is released. Additional bits are transmitted for synchronization of transmitter and receiver clocks and for security checks. The address organization provides a wide range of simultaneous applications without interference between systems. The receiver accepts the decoded command only if the transmitted address matches the address selected at the receiver. 16 addresses are available for this purpose.

The reference oscillator is controlled by a cheap ceramic or LC resonator. Two types of transmission mode are available : "Flash" or "Carrier" mode.

The M709 is a simplified version of the M710 which can only transmit 40 commands with 16 possible addresses. The M710 on the other hand has the full system capacity : it can transmit 64 commands with 16 addresses.

The M709 and M710 are produced with CMOS Si-gate technology and are available in 24 and 28-pin dual in-line plastic packages respectively.

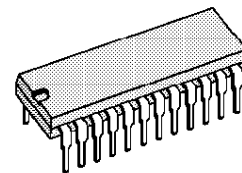

DIP24
(Plastic Package)

ORDER CODE : M709B1 / M709AB1

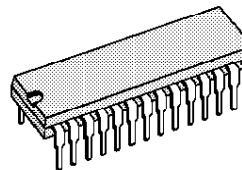

DIP28
(Plastic Package)

ORDER CODE : M710B1 / M710AB1

M709 - M709A - M710 - M710A

PIN CONNECTIONS

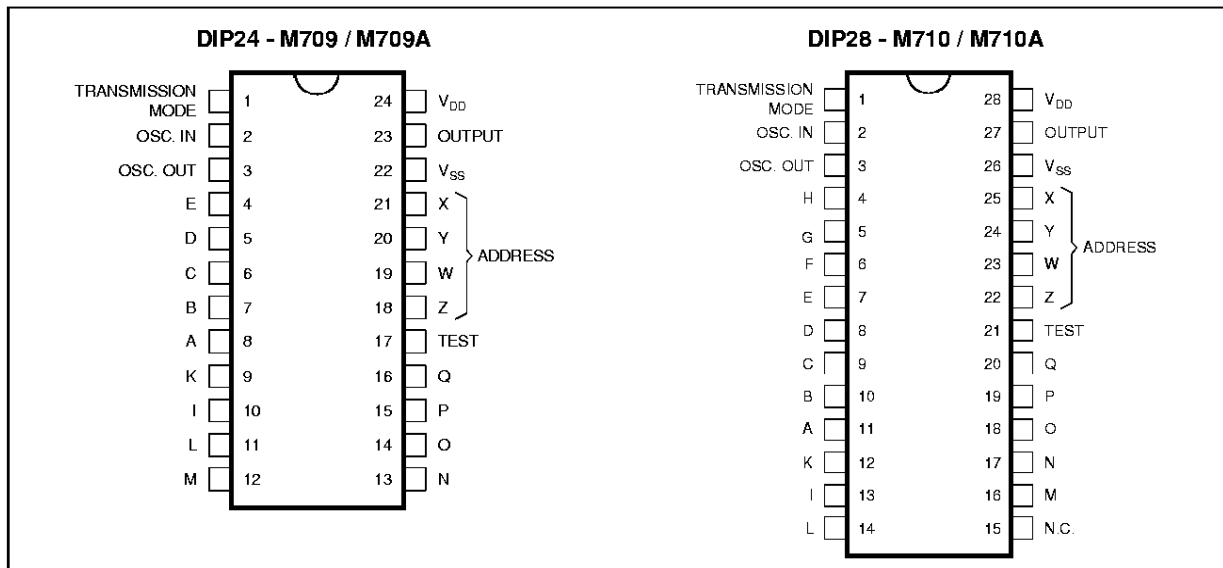

Note : The test pin must be connected to V_{SS}.

FUNCTIONAL DESCRIPTION

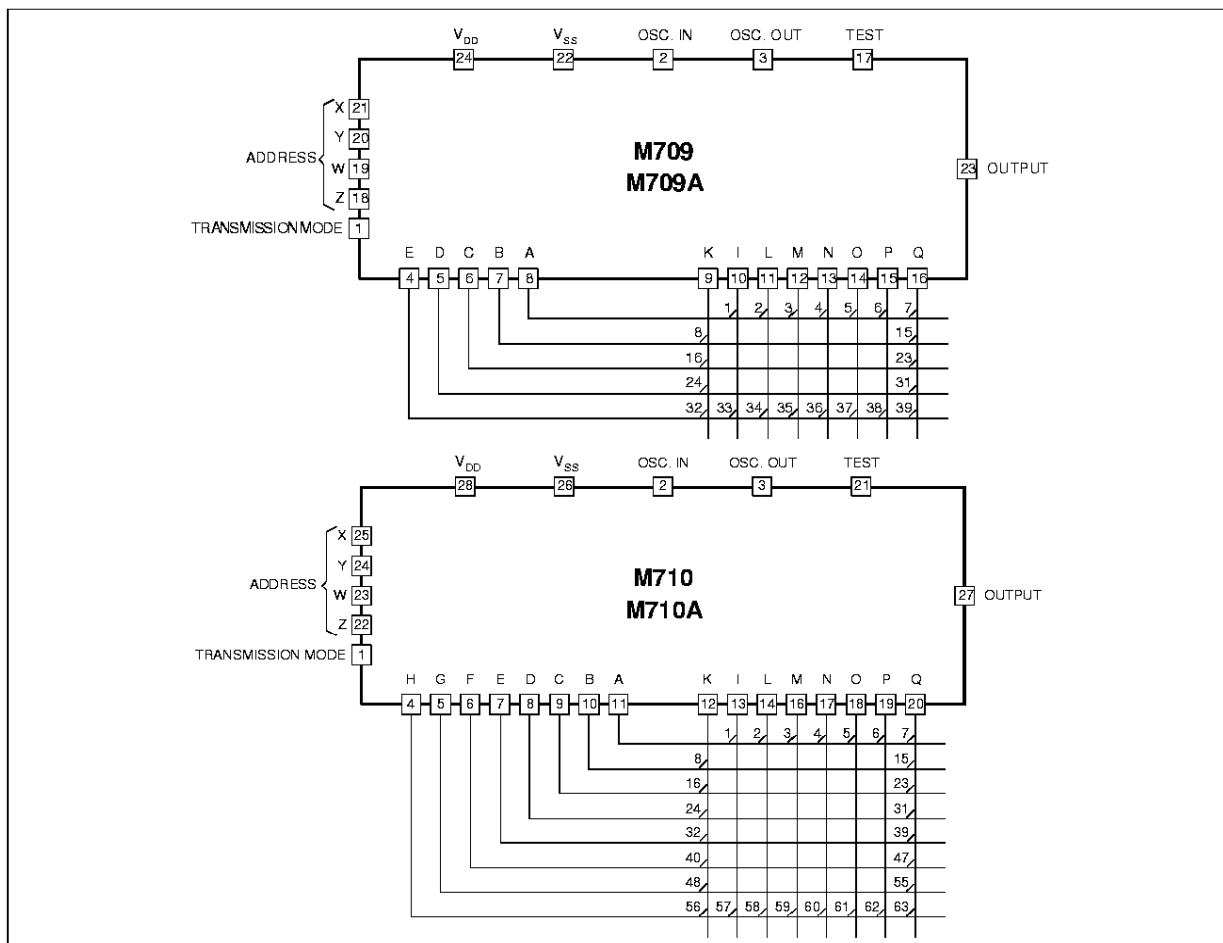

BLOCK DIAGRAM

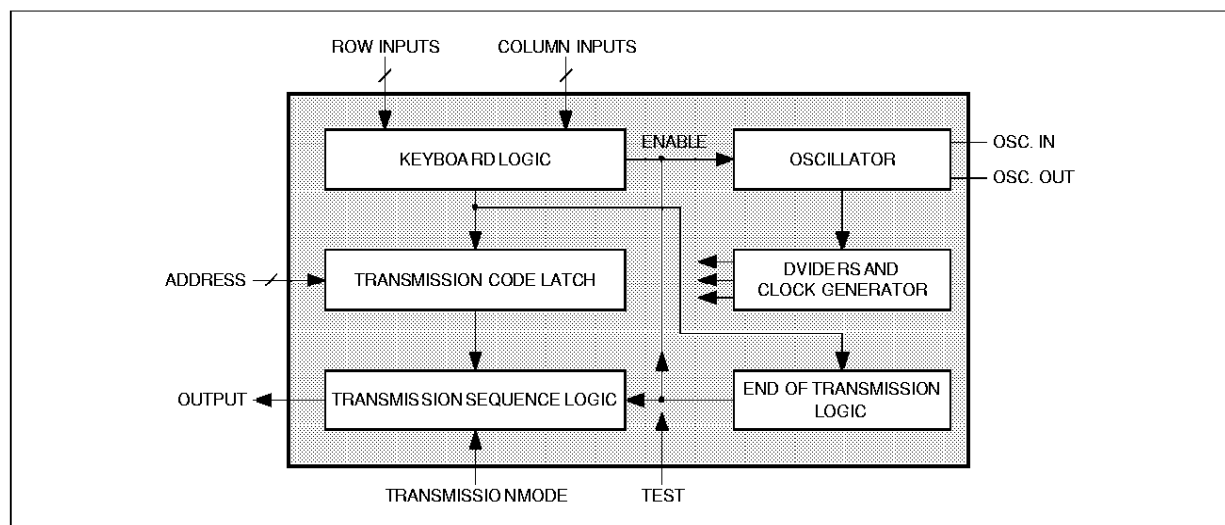

709-03.EPS

ABSOLUTE MAXIMUM RATINGS

Symbol	Parameter	Value	Unit
V _{DD}	Supply Voltage	-0.3 to 12	V
V _I	Input Voltage	-0.3 to V _{DD} +0.3	V
I _o	IR Output Current (t < 50μs)	10	mA
P _{tot}	Total Package Power Dissipation	200	mW
T _{oper}	Operating Temperature	0 to 70	°C
T _{stg}	Storage Temperature	-55 to 125	°C

709-01.TBL

Stresses above those listed under "Absolute Maximum Ratings" may cause permanent damage to the device. This is a stress rating only and functional operation of the device at these or any other conditions above those indicated in the operational sections of this specification is not implied. Exposure to absolute maximum rating conditions for extended periods may affect device reliability.

RECOMMENDED OPERATING CONDITIONS

Symbol	Parameter	Value	Unit
V _{DD}	Supply Voltage Range : M709/M710 M709A/M710A	4.5 to 10.5 3 to 10.5	V
V _I	Input Voltage Range	0 to V _{DD}	V
I _o	IR Output Current (t < 50μs)	max. 2.5	mA
f _{ref}	Reference Frequency Range	445 to 510	kHz
T _{oper}	Operating Temperature Range	0 to 70	°C
r _s	Serial Resistance of a Closed Key Contact	max. 2.5	kΩ
r _p	Parallel Resistance of Open Key Contact	min. 2.2	MΩ
R _s	Serial Resistance of the Ceramic Resonator	max. 20	Ω

709-02.TBL

M709 - M709A - M710 - M710A

STATIC ELECTRICAL CHARACTERISTICS (over recommended operating conditions)

Typical values are at 9V and T_{AMB} = 25°C

Symbol	Parameter	Pins	Test Conditions	Min.	Typ.	Max.	Unit
I _{DD}	Supply Current	M709 Pin 24 M710 Pin 28	V _{DD} = 9V, IR Output open : Stand-by Operating (one key closed)		5 4	15 7	μA mA
I _{OH}	High State IR Output Current	M709 Pin 23 M710 Pin 27	V _{DD} = 9V, V _{OH} = 8V V _{DD} = 4.5V, V _{OH} = 3.5V	-1.5 -0.3	-2.5 -0.5		mA mA
I _{OL}	Low State IR Output Current	M709 Pin 23 M710 Pin 27	V _{DD} = 9V, V _{OL} = 1V V _{DD} = 4.5V, V _{OL} = 1V	1.5 0.3	2.5 0.5		mA mA
V _{TH}	Input Threshold High	Selection Inputs A to H	V _{DD} = 9V V _{DD} = 4.5V			6 3	V V
V _{TL}	Input Threshold Low	Selection Inputs K to Q	V _{DD} = 9V V _{DD} = 4.5V	3 1.5			V V
I _{IL}	Input Low Current	Pull-up Inputs A to H	V _{DD} = 9V, V _{IL} = 4.5V	-60		-300	μA
I _{IH}	Input High Current	Pull-down Inputs K to Q	V _{DD} = 9V, V _{IH} = 4.5V	60		300	μA
I _{IH}	Input High Current	Address Selection Inputs	V _{DD} = 9V, V _{IL} = 8.25V (oscillator running)			150	μA
I _L	Input Leakage Current	Trans. Mode Test Pin	V _{DD} = 9V, V _{IN} = 0 to 9V			1	μA
I _{OS}	Output Current	Osc. Out	V _{DD} = 9V, Osc. In. = V _{SS}	-2		-8	μA

709-03.TBL

TRUTH TABLE

Command No	Input Code																Command Bits					
	A	B	C	D	E	F	G	H	K	I	L	M	N	O	P	Q	C1	C2	C3	C4	C5	C6
0	END OF TRANSMISSION																0	0	0	0	0	0
1	X								X								1	0	0	0	0	0
2	X									X							0	1	0	0	0	0
3	X										X						1	1	0	0	0	0
4	X											X					0	0	1	0	0	0
5	X												X				1	0	1	0	0	0
6	X													X			0	1	1	0	0	0
7	X														X		1	1	1	0	0	0
8		X							X								0	0	0	1	0	0
9		X								X							1	0	0	1	0	0
10		X									X						0	1	0	1	0	0
11		X										X					1	1	0	1	0	0
12		X											X				0	0	1	1	0	0
13		X												X			1	0	1	1	0	0
14		X													X		0	1	1	1	0	0
15		X														X	1	1	1	1	0	0
16			X						X								0	0	0	1	0	0
17			X							X							1	0	0	1	0	0
18			X								X						0	1	0	1	0	0
19			X									X					1	1	0	1	0	0
20			X										X				0	0	1	1	0	0
21			X											X			1	0	1	1	0	0
22			X												X		0	1	1	1	0	0
23			X													X	1	1	1	1	0	0
24				X					X								0	0	0	1	0	0
25				X						X							1	0	0	1	0	0
26				X							X						0	1	0	1	0	0
27				X								X					1	1	0	1	0	0
28				X									X				0	0	1	1	0	0
29				X										X			1	0	1	1	0	0
30				X											X		0	1	1	1	0	0
31				X												X	1	1	1	1	0	0

709-04.TBL

TRUTH TABLE (continued)

Command No	Input Code												Command Bits									
	A	B	C	D	E	F	G	H	K	I	L	M	N	O	P	Q	C1	C2	C3	C4	C5	C6
32					X				X								0	0	0	1	0	0
33					X					X							1	0	0	1	0	0
34					X						X						0	1	0	1	0	0
35					X							X					1	1	0	1	0	0
36					X								X				0	0	1	1	0	0
37					X									X			1	0	1	1	0	0
38					X										X		0	1	1	1	0	0
39					X											X	1	1	1	1	0	0
40						X			X								0	0	0	1	0	1
41						X				X							1	0	0	1	0	1
42						X					X						0	1	0	1	0	1
43						X						X					1	1	0	1	0	1
44						X							X				0	0	1	1	0	1
45						X								X			1	0	1	1	0	1
46						X									X		0	1	1	1	0	1
47						X										X	1	1	1	1	0	1
48							X		X								0	0	0	0	1	1
49							X			X							1	0	0	0	1	1
50							X				X						0	1	0	0	1	1
51							X					X					1	1	0	0	1	1
52							X						X				0	0	1	0	1	1
53							X							X			1	0	1	0	1	1
54							X								X		0	1	1	0	1	1
55							X									X	1	1	1	0	1	1
56								X	X								0	0	0	1	1	1
57								X		X							1	0	0	1	1	1
58								X			X						0	1	0	1	1	1
59								X				X					1	1	0	1	1	1
60								X					X				0	0	1	1	1	1
61								X						X			1	0	1	1	1	1
62								X							X		0	1	1	1	1	1
63								X								X	1	1	1	1	1	1

709-06 TBL

DESCRIPTION

The signals are transmitted with infrared light using pulse code modulation. Each word consists of 12 bits. The binary information of a bit is determined by the time interval between two pulses.

If "T" is the time base, the bits are coded as follows :

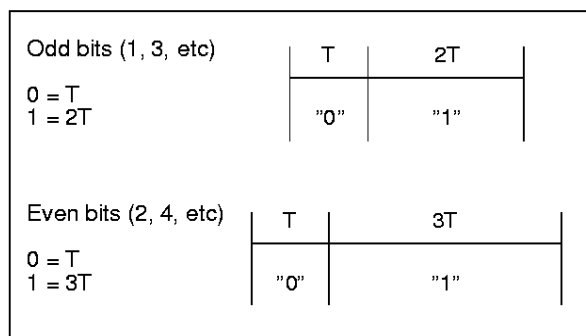

709-06 EPS / 709-07 EPS

The different code introduced for the even and odd "1s" improves the capability to recognize false codes at the receiver end. For example the double error which can cause the exchange "10" with "01" is easily detected.

A parity bit is also added in order to further increase the reliability of the transmission. This bit is "1" if the number of transmitted "1s" is even while it is "0" if the number of transmitted "1s" is odd.

In addition, every word contains a preliminary pulse, a start pulse and a stop pulse. The spacing between the preliminary and the start pulse is 4T. This is followed after 1T by 11 data pulses (one parity bit), and terminated after 4T interval by a stop pulse.

Consequently, a word in which the binary digit 0 occurs ten times has a total duration of 21T.

A word containing ten "1s" has a duration of 36T.

Example :

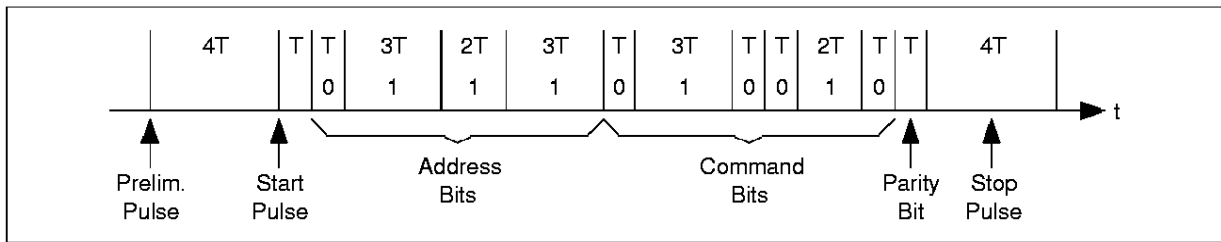

709-08.EPS

SYNCHRONIZATION BETWEEN TRANSMITTER AND RECEIVER

The transmitter and the receiver can operate with different reference frequencies.

Typical values suitable for correct operation of the system should be between 445 and 510kHz, using a cheap ceramic resonator.

Synchronization between the transmitter and the receiver, necessary to obtain the wide range of frequency tolerance described above is achieved by measuring in the receiver the interval between the start pulse and the first data pulse, storing this value and using it as time base T.

The contact must be continuously closed for a minimum of 25ms.

Double and multiple contact operations are not accepted.

The command information is repeatedly transmitted at intervals of 102ms ($f_{ref} = 500kHz$) as long as the push button remains operated.

When the contact is interrupted the circuit transmits, after a pause of about 18 ms, the "end of transmission code" and returns to stand-by mode.

If the contact is interrupted while a command is being transmitted the circuit carries on with the transmission to the end. After a pause of about 18 ms it transmits the end of transmission code.

KEYBOARD (pins A to Q) / CODE REPETITION

One column input (K to Q) has to be connected to one row (A to H) input to activate the transmitter.

No command is accepted until the "end of transmission code" is over.

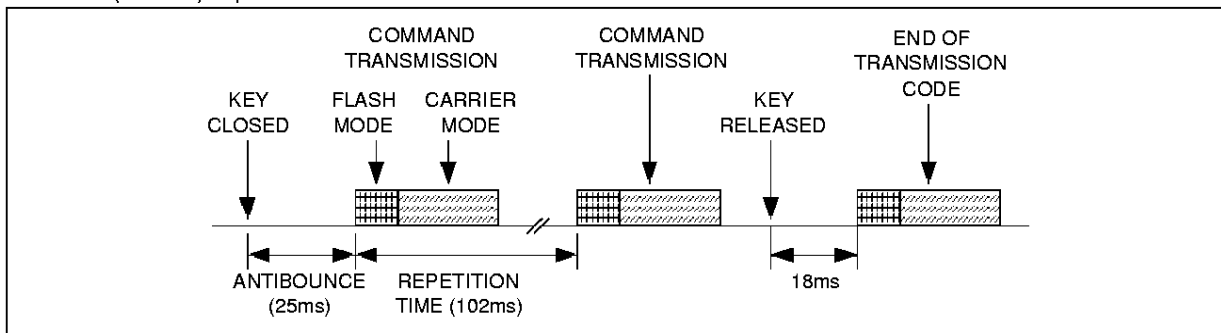

709-09.EPS

TRANSMISSION MODE (pin 1)

The M709/M710 can operate in Flash (pin 1 = V_{DD}) or Carrier (pin 1 = V_{SS}) transmission modes. Using a reference frequency of 500kHz the output signal has these formats :

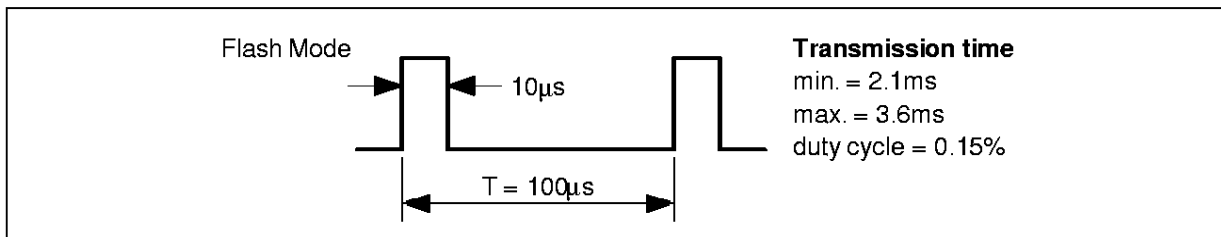

709-10.EPS

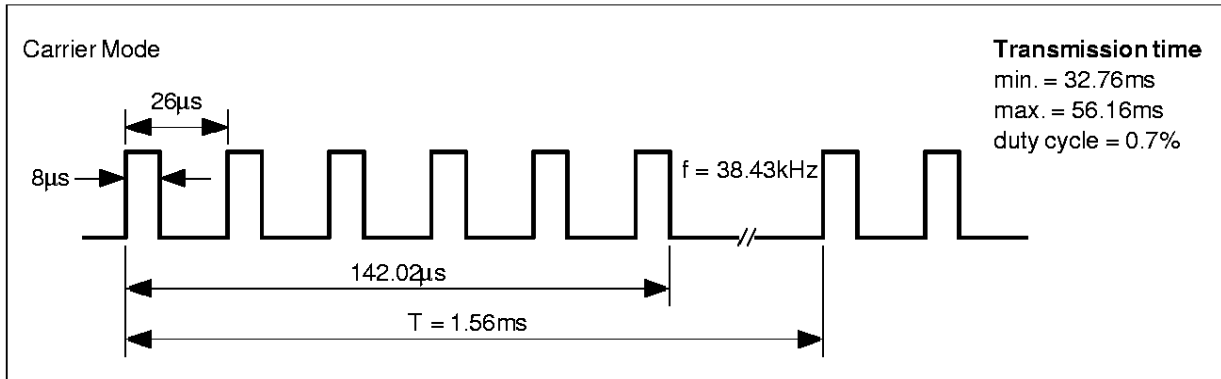

709-11.EPS

ADDRESS (pins X, Y, W, Z)

The Address information is coded and transmitted as follows :

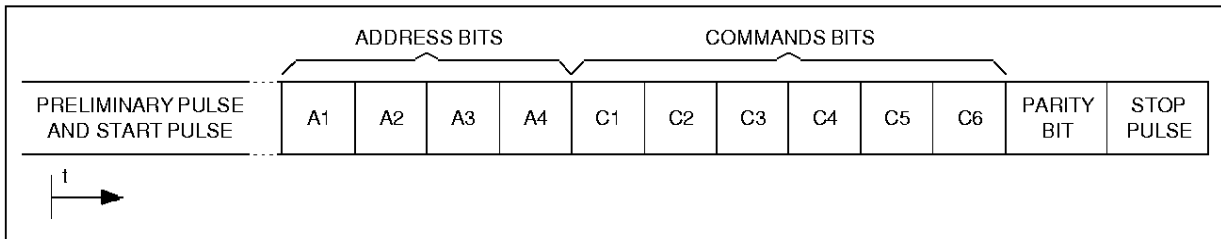

709-12.EPS

Address Number	Transmitted Code				Address Input Code			
	A1	A2	A3	A4	X	Y	W	Z
1	0	0	0	0	L	L	L	L
2	1	0	0	0	H	L	L	L
3	0	1	0	0	L	H	L	L
4	1	1	0	0	H	H	L	L
5	0	0	1	0	L	L	H	L
6	1	0	1	0	H	L	H	L
7	0	1	1	0	L	H	H	L
8	1	1	1	0	H	H	H	L
9	0	0	0	1	L	L	L	H
10	1	0	0	1	H	L	L	H
11	0	1	0	1	L	H	L	H
12	1	1	0	1	H	H	L	H
13	0	0	1	1	L	L	H	H
14	1	0	1	1	H	L	H	H
15	0	1	1	1	L	H	H	H
16	1	1	1	1	H	H	H	H

709-06.TBL

The address inputs have internal pull-downs which are disabled during stand-by.

Single Address Selection

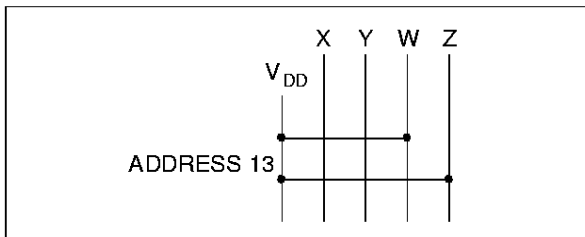

709-13.EPS

Multiple Address Selection

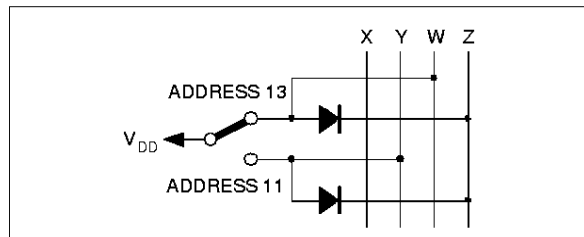

709-14.EPS

Note : unused inputs can be left open or connected to V_{SS}.

TYPICAL APPLICATION

FLASH MODE

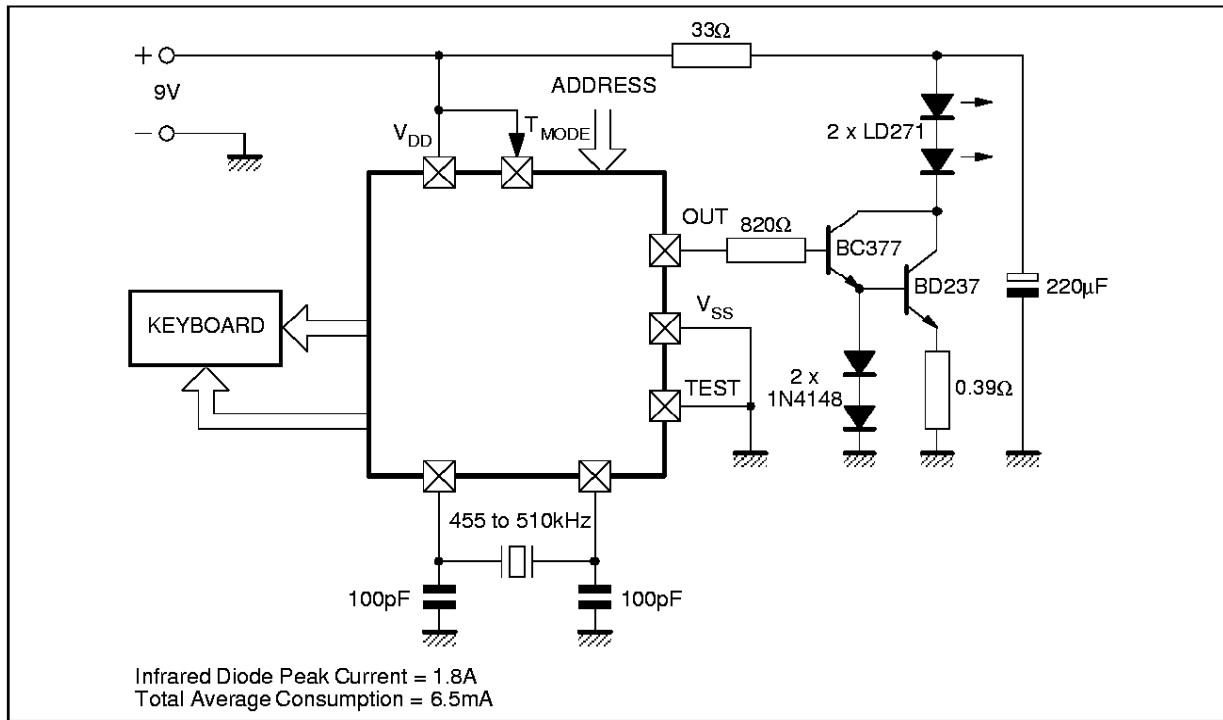

709-16.EPS

CARRIER MODE

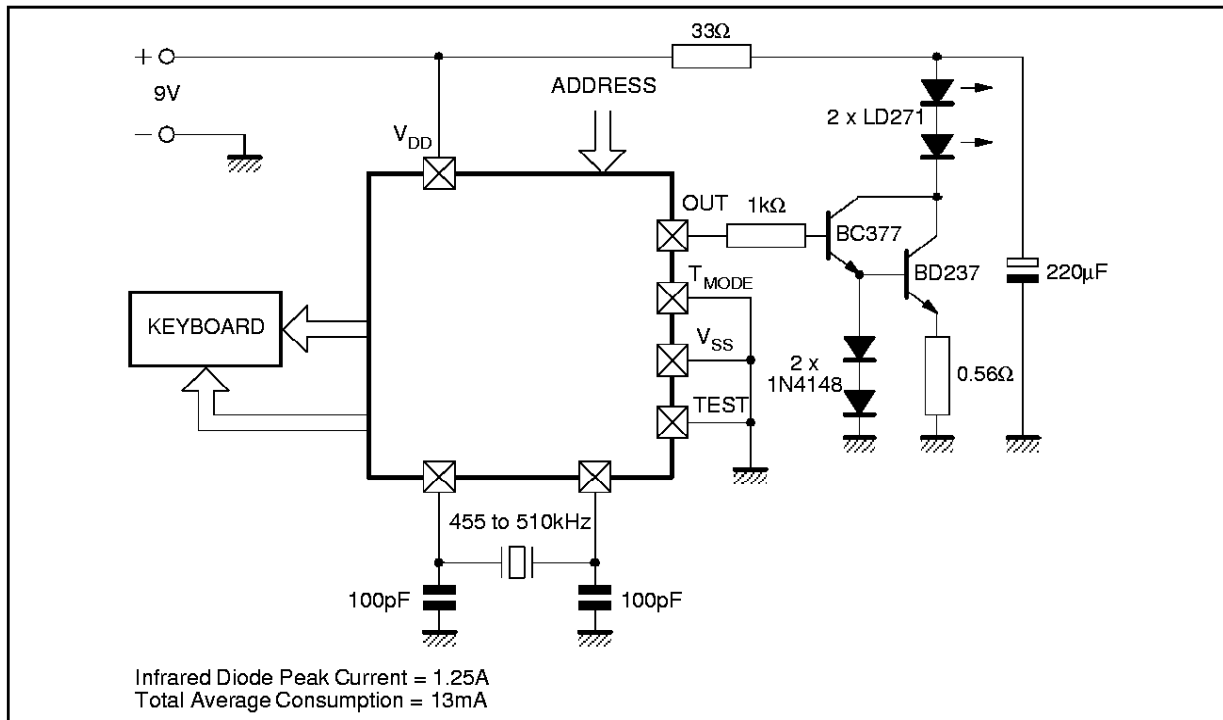

709-16.EPS

PACKAGE MECHANICAL DATA

24 PINS - PLASTIC DIP

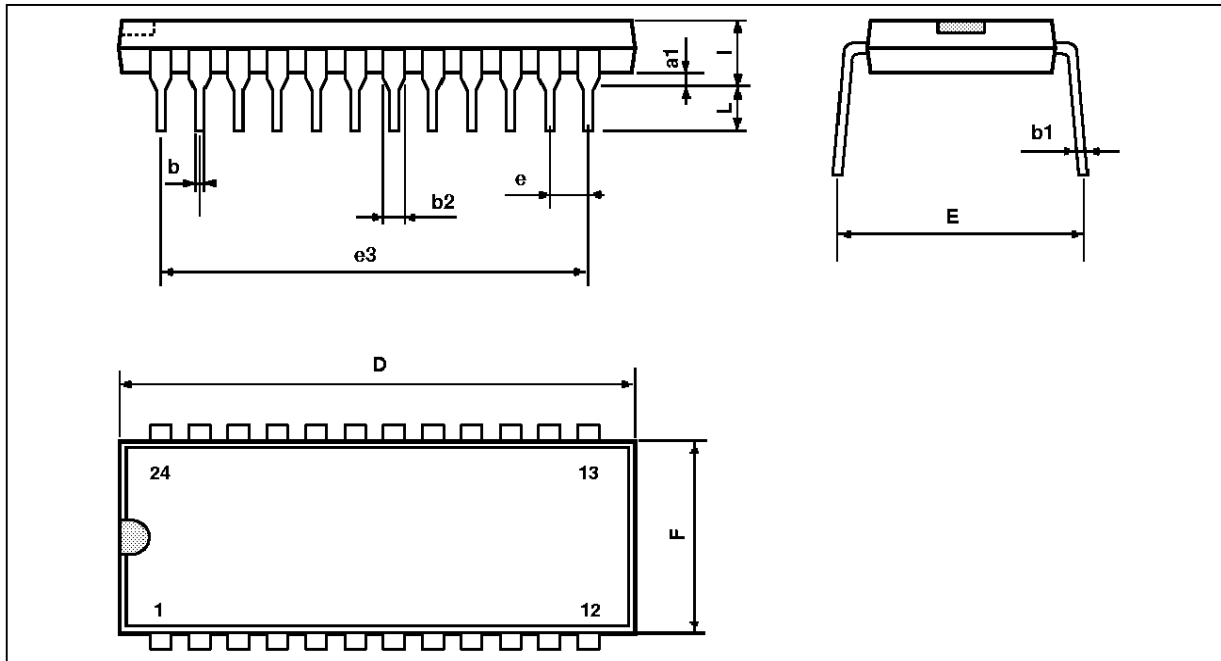

PM-DIP24EFS

Dimensions	Millimeters			Inches		
	Min.	Typ.	Max.	Min.	Typ.	Max.
a1		0.63			0.025	
b		0.45			0.018	
b1	0.23		0.31	0.009		0.012
b2		1.27			0.050	
D			32.2			1.268
E	15.2		16.68	0.598		0.657
e		2.54			0.100	
e3		27.94			1.100	
F			14.1			0.555
i		4.445			0.175	
L		3.3			0.130	

DIP24.TBL

M709 - M709A - M710 - M710A

PACKAGE MECHANICAL DATA

28 PINS - PLASTIC DIP

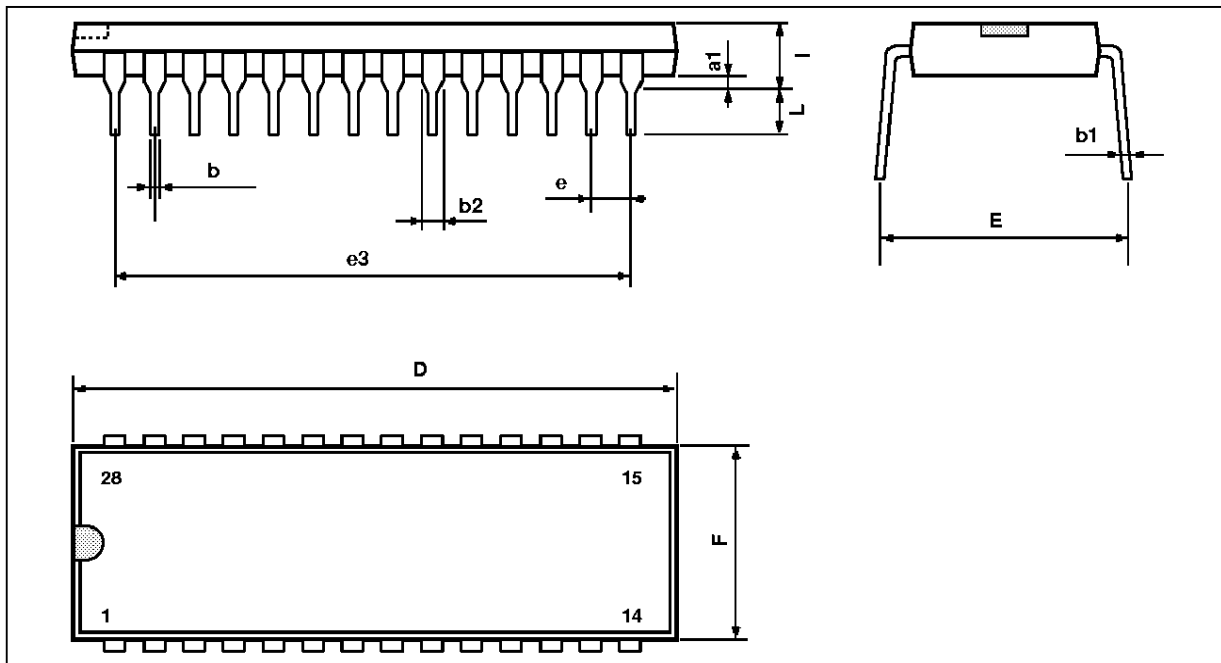

Dimensions	Millimeters			Inches		
	Min.	Typ.	Max.	Min.	Typ.	Max.
a1		0.63			0.025	
b		0.45			0.018	
b1	0.23		0.31	0.009		0.012
b2		1.27			0.050	
D			37.4			1.470
E	15.2		16.68	0.598		0.657
e		2.54			0.100	
e3		33.02			1.300	
F			14.1			0.555
i		4.445			0.175	
L		3.3			0.130	

Information furnished is believed to be accurate and reliable. However, SGS-THOMSON Microelectronics assumes no responsibility for the consequences of use of such information nor for any infringement of patents or other rights of third parties which may result from its use. No licence is granted by implication or otherwise under any patent or patent rights of SGS-THOMSON Microelectronics. Specifications mentioned in this publication are subject to change without notice. This publication supersedes and replaces all information previously supplied. SGS-THOMSON Microelectronics products are not authorized for use as critical components in life support devices or systems without express written approval of SGS-THOMSON Microelectronics.

© 1995 SGS-THOMSON Microelectronics - All Rights Reserved

Purchase of I²C Components of SGS-THOMSON Microelectronics, conveys a license under the Philips I²C Patent. Rights to use these components in a I²C system, is granted provided that the system conforms to the I²C Standard Specifications as defined by Philips.

SGS-THOMSON Microelectronics GROUP OF COMPANIES

Australia - Brazil - China - France - Germany - Hong Kong - Italy - Japan - Korea - Malaysia - Malta - Morocco
The Netherlands - Singapore - Spain - Sweden - Switzerland - Taiwan - Thailand - United Kingdom - U.S.A.