



# STV8172A

## Vertical deflection booster for 3 App TV/monitor applications with 70 V flyback generator

### Features

- Power amplifier
- Flyback generator
- Stand-by control
- Output current up to 3.0 App
- Thermal protection

### Description

Designed for monitors and high performance TVs, the STV8172A vertical deflection booster delivers flyback voltages up to 70V.

The STV8172A operates with supplies up to 35V and provides up to 3 A<sub>PP</sub> output current to drive the yoke.

The STV8172A is offered in a Heptawatt plastic package.

In double-supply applications, a stand-by state will be reached by stopping the (+) supply alone.

Figure 1. Heptawatt package

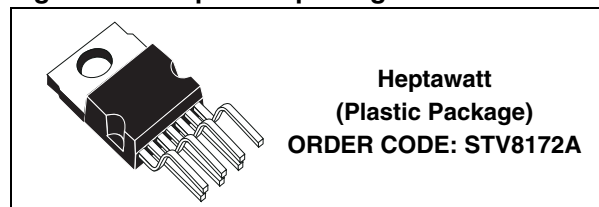
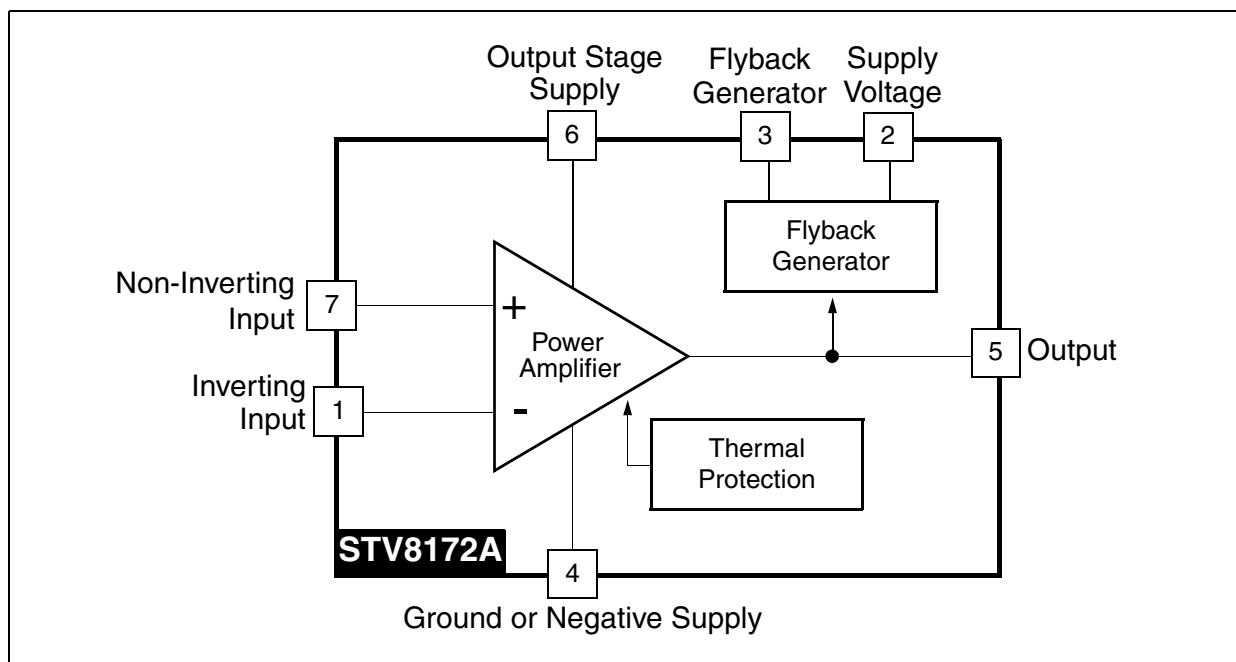
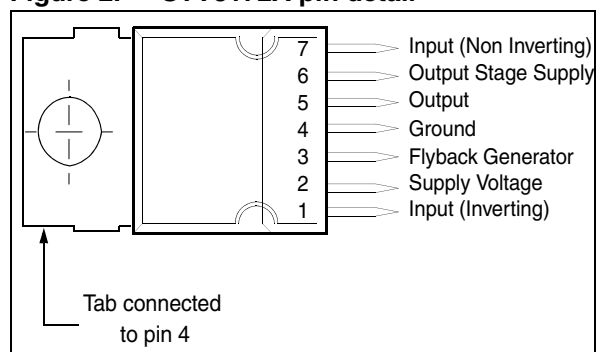

Figure 2. STV8172A pin detail



# Contents

- 1 Absolute maximum ratings ..... 3**
- 2 Thermal data ..... 4**
- 3 Electrical characteristics ..... 5**
- 4 Application hints ..... 7**
  - 4.1 DC-coupled application ..... 7
    - 4.1.1 Application hints ..... 8
    - 4.1.2 Ripple rejection ..... 9
  - 4.2 AC-coupled applications ..... 10
    - 4.2.1 Application hints ..... 10
  - 4.3 Application with differential-output drivers ..... 11
    - 4.3.1 Centering ..... 12
    - 4.3.2 Peak current ..... 12
    - 4.3.3 Ripple rejection ..... 12
    - 4.3.4 Secondary breakdown diagrams ..... 13
- 5 Mounting instructions ..... 14**
- 6 Pin configuration ..... 15**
- 7 Package mechanical data ..... 16**
  - 7.1 Lead-free packaging ..... 17
- 8 Revision history ..... 18**

# 1 Absolute maximum ratings

**Table 1. Absolute maximum ratings**

Symbol	Parameter	Value	Unit
<b>Voltage</b>			
$V_S$	Supply voltage (pin 2) - Note 1 and Note 2	40	V
$V_5, V_6$	Flyback peak voltage - Note 2	70	V
$V_3$	Voltage at Pin 3 - Note 2, Note 3 and Note 6	-0.4 to ( $V_S + 3$ )	V
$V_1, V_7$	Amplifier input voltage - Note 2, Note 6 and Note 7	- 0.4 to ( $V_S + 2$ ) or +40	V
<b>Current</b>			
$I_0$ (1)	Output peak current at $f = 50$ to $200$ Hz, $t \leq 10\mu s$ - Note 4	$\pm 5$	A
$I_0$ (2)	Output peak current non-repetitive - Note 5	$\pm 2$	A
$I_3$ Sink	Sink current, $t < 1$ ms - Note 3	2	A
$I_3$ Source	Source current, $t < 1$ ms	2	A
$I_3$	Flyback pulse current at $f=50$ to $200$ Hz, $t \leq 10\mu s$ - Note 4	$\pm 5$	A
<b>ESD Susceptibility</b>			
ESD1	Human body model (100 pF discharged through 1.5 k $\Omega$ )	2	kV
ESD2	EIAJ standard (200 pF discharged through 0 $\Omega$ )	300	V
<b>Temperature</b>			
$T_s$	Storage temperature	-40 to 150	$^{\circ}\text{C}$
$T_j$	Junction temperature	+150	$^{\circ}\text{C}$

- Note:
- 1 Usually the flyback voltage is slightly more than  $2 \times V_S$ . This must be taken into consideration when setting  $V_S$ .
  - 2 Versus pin 4
  - 3  $V_3$  is higher than  $V_S$  during the first half of the flyback pulse.
  - 4 Such repetitive output peak currents are usually observed just before and after the flyback pulse.
  - 5 This non-repetitive output peak current can be observed, for example, during the Switch-On/Switch-Off phases. This peak current is acceptable providing the SOA is respected (Figure 10 and Figure 11).
  - 6 All pins have a reverse diode towards pin 4, these diodes should never be forward-biased.
  - 7 Input voltages must not exceed the lower value of either  $V_S + 2$  or 40 volts.

## 2 Thermal data

**Table 2. Thermal data**

Symbol	Parameter	Value	Unit
$R_{thJC}$	Junction-to-case thermal resistance	3	°C/W
$T_T$	Temperature for thermal shutdown	150	°C
$T_J$	Recommended max. junction temperature	120	°C

### 3 Electrical characteristics

$V_S = 34\text{ V}$ ,  $T_{AMB} = 25^\circ\text{C}$ , unless otherwise specified.

**Table 3. Electrical characteristics**

Symbol	Parameter	Test Conditions	Min.	Typ.	Max.	Unit	Figure
<b>Supply</b>							
$V_S$	Operating supply voltage range ( $V_2$ - $V_4$ )	See note below <sup>(1)</sup>	10		35	V	
$I_2$	Pin 2 quiescent current	$I_3 = 0$ , $I_5 = 0$		5	20	mA	Figure 3
$I_6$	Pin 6 quiescent current	$I_3 = 0$ , $I_5 = 0$ , $V_6 = 35\text{V}$	8	19	50	mA	Figure 3
<b>Input</b>							
$I_1$	Input bias current	$V_1 = 1\text{ V}$ , $V_7 = 2.2\text{ V}$		- 0.6	-1.5	$\mu\text{A}$	Figure 3
$I_7$	Input bias current	$V_1 = 2.2\text{ V}$ , $V_7 = 1\text{ V}$		- 0.6	-1.5	$\mu\text{A}$	
$V_{IR}$	Operating input voltage range		0		$V_S - 2$	V	
$V_{I0}$	Offset voltage			2		mV	
$\Delta V_{I0}/dt$	Offset drift versus temperature			10		$\mu\text{V}/^\circ\text{C}$	
<b>Output</b>							
$I_0$	Operating peak output current	$0^\circ < T_{case} < 125^\circ\text{C}$			$\pm 1.25$	A	
$V_{5L}$	Output saturation voltage to pin 4	$I_5 = 1.25\text{ A}$		0.9	1.6	V	Figure 5
$V_{5H}$	Output saturation voltage to pin 6	$I_5 = -1.25\text{ A}$		1.5	2.2	V	Figure 4
<b>Standby</b>							
$V_{5STBY}$	Output voltage in standby	$V_1 = V_7 = V_S = 0$ <sup>(2)</sup>					Figure 6
<b>Miscellaneous</b>							
G	Voltage gain		80			dB	
$V_{D5-6}$	Diode forward voltage between pins 5-6	$I_5 = 1.25\text{ A}$		1.5	2.1	V	
$V_{D3-2}$	Diode forward voltage between pins 3-2	$I_3 = 1.25\text{ A}$		1.5	2.1	V	
$V_{3SL}$	Saturation voltage on pin 3	$I_3 = 20\text{ mA}$		0.4	1	V	Figure 5
$V_{3SH}$	Saturation voltage to pin 2 (2nd part of flyback)	$I_3 = -1.25\text{ A}$		1.8	2.6	V	

1. In normal applications, the peak flyback voltage is slightly greater than  $2 \times (V_S - V_4)$ . Therefore,  $(V_S - V_4) = 35\text{ V}$  is not allowed without special circuitry.

2. Refer to [Figure 6](#), standby condition.

Figure 3. Measurement of  $I_1$ ,  $I_2$  and  $I_6$

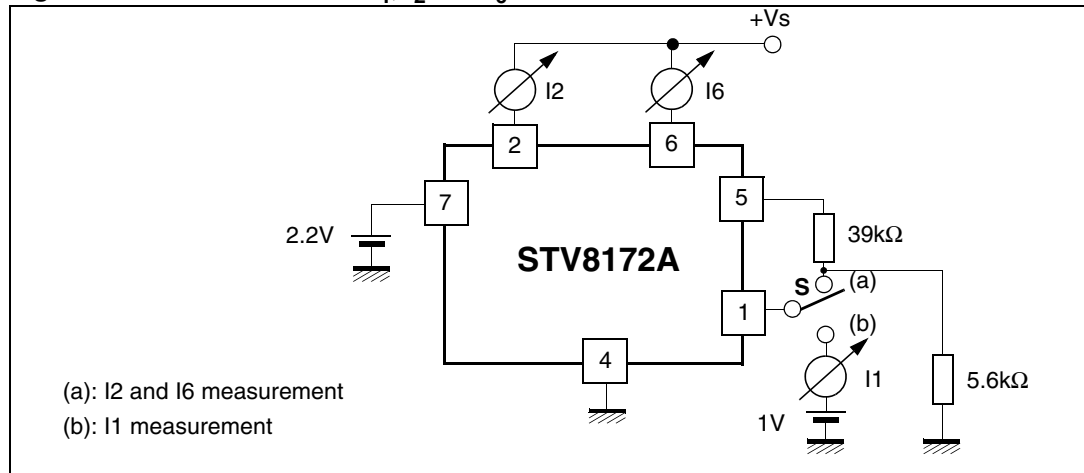

Figure 4. Measurement of  $V_{5H}$

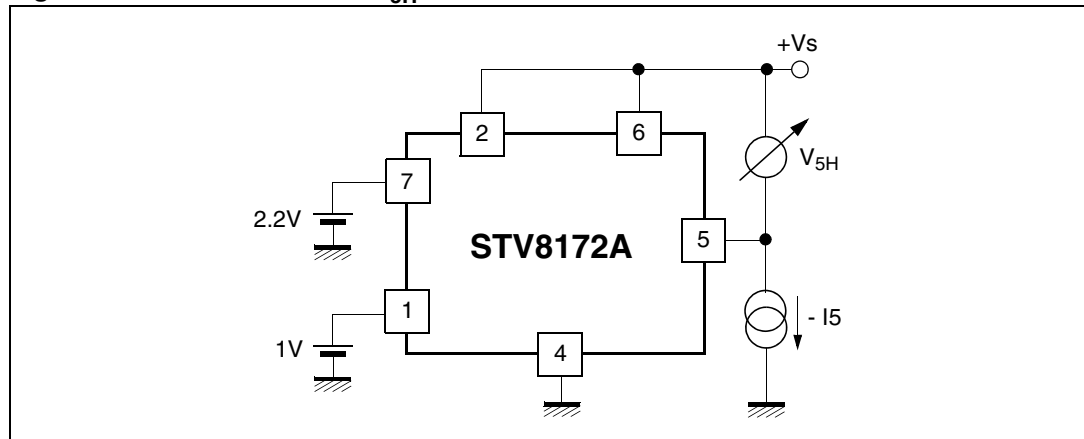
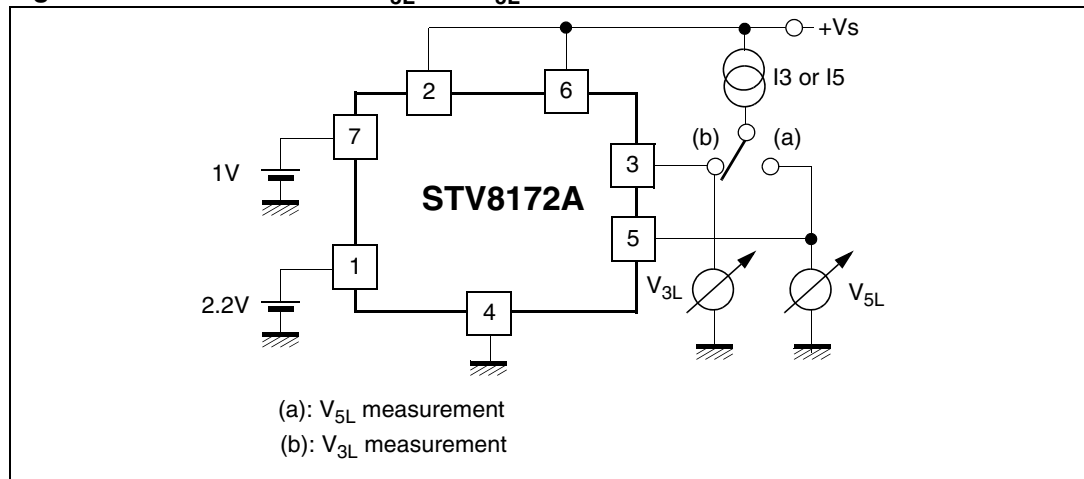

Figure 5. Measurement of  $V_{3L}$  and  $V_{5L}$



## 4 Application hints

The yoke can be coupled either in AC or DC.

### 4.1 DC-coupled application

When DC coupled (see [Figure 6](#)), the display vertical position can be adjusted with input bias. On the other hand, 2 supply sources ( $V_S$  and  $-V_{EE}$ ) are required.

A standby state will be reached by switching OFF the positive supply alone. In this state, where both inputs are the same voltage as pin 2 or higher, the output will sink negligible current from the deviation coil.

Figure 6. DC-coupled application

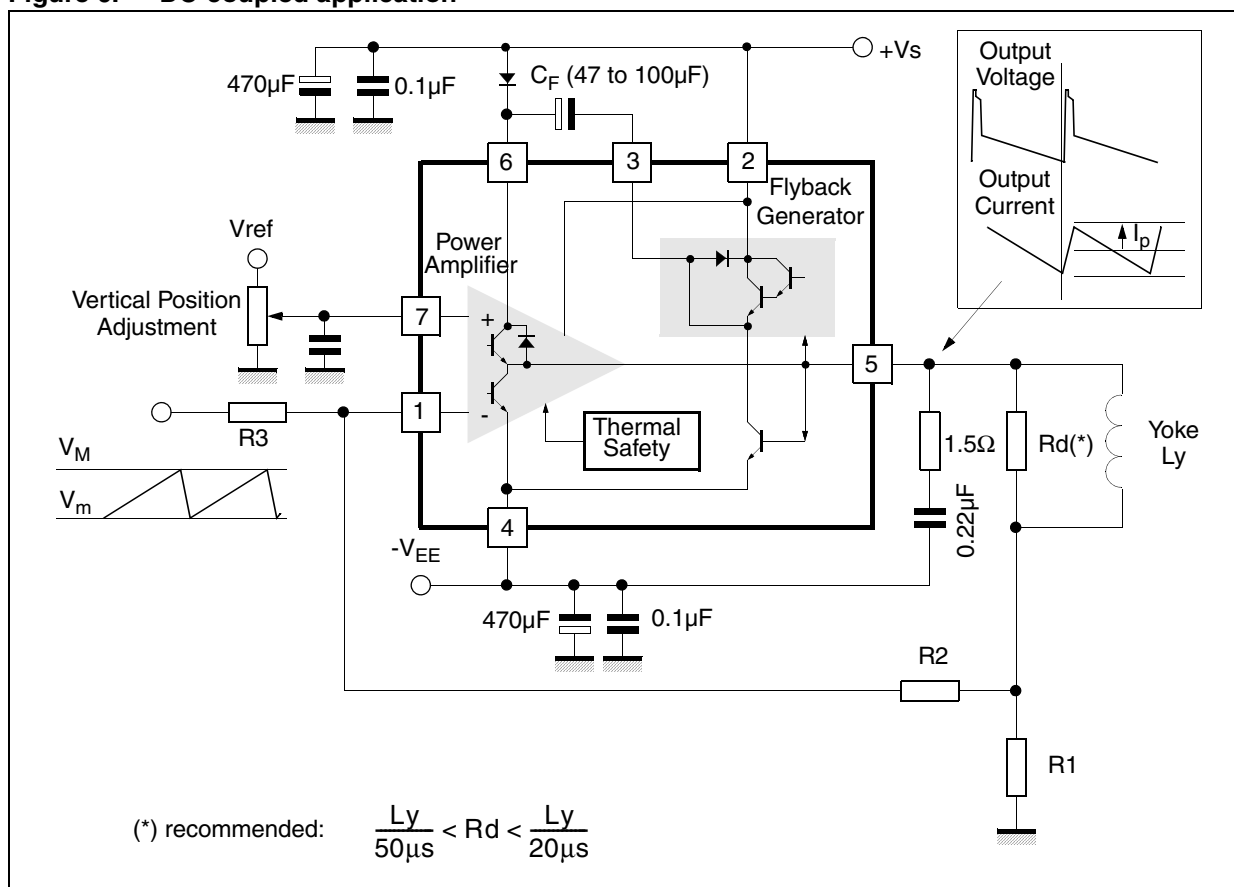

### 4.1.1 Application hints

For calculations, treat the IC as an op-amp, where the feedback loop maintains  $V_1 = V_7$ .

#### Centering

Display will be centered (null mean current in yoke) when voltage on pin 7 is ( $R_1$  is negligible):

$$V_7 = \frac{V_M + V_m}{2} \times \left( \frac{R_2}{R_2 + R_3} \right)$$

#### Peak current

$$I_P = \frac{(V_M - V_m)}{2} \times \frac{R_2}{R_1 \times R_3}$$

Example: for  $V_m = 2$  V,  $V_M = 5$  V and  $I_P = 1$  A

Choose  $R_1$  in the 1  $\Omega$  range, for instance  $R_1 = 1$   $\Omega$

From equation of peak current:

$$\frac{R_2}{R_3} = \frac{2 \times I_P \times R_1}{V_M - V_m} = \frac{2}{3}$$

Then choose  $R_2$  or  $R_3$ . For instance, if  $R_2 = 10$  k $\Omega$  then  $R_3 = 15$  k $\Omega$

Finally, the bias voltage on pin 7 should be:

$$V_7 = \frac{V_M + V_m}{2} \times \frac{1}{1 + \frac{R_3}{R_2}} = \frac{7}{2} \times \frac{1}{2.5} = 1.4$$
 V



### 4.1.2 Ripple rejection

When both ramp signal and bias are provided by the same driver IC, you can gain natural rejection of any ripple caused by a voltage drop in the ground (see [Figure 7](#)), if you manage to apply the same fraction of ripple voltage to both booster inputs. For that purpose, arrange an intermediate point in the bias resistor bridge, such that  $(R_8 / R_7) = (R_3 / R_2)$ , and connect the bias filtering capacitor between the intermediate point and the local driver ground. Of course,  $R_7$  should be connected to the booster reference point, which is the ground side of  $R_1$ .

Figure 7. Ripple rejection

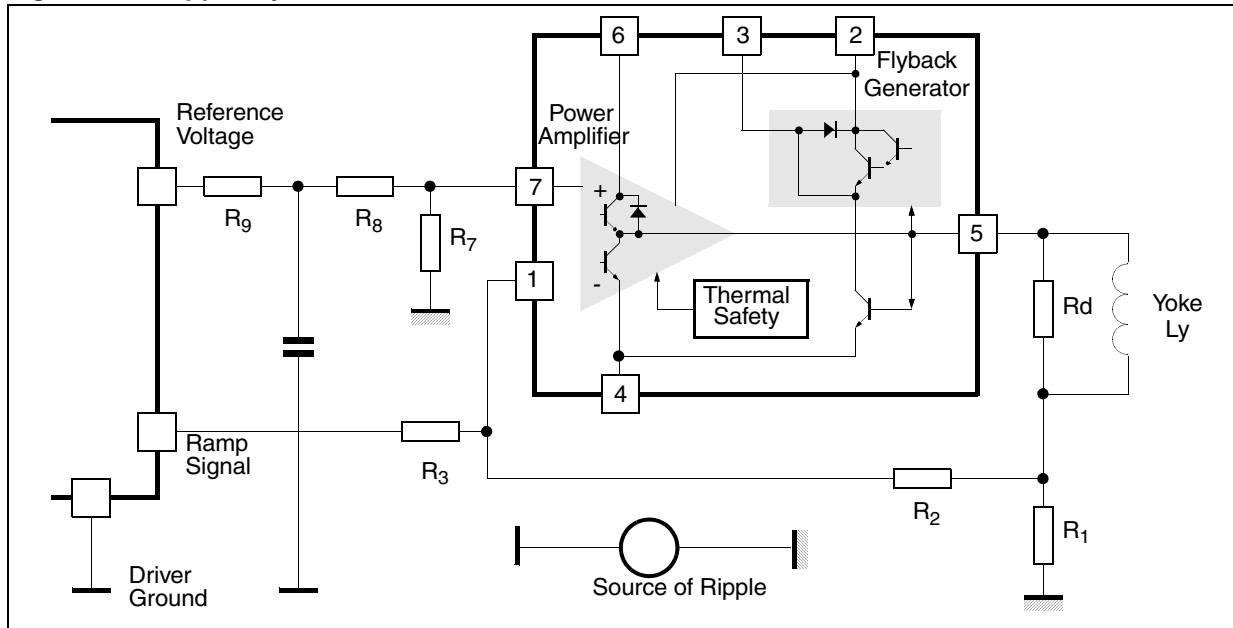

## 4.2 AC-coupled applications

In AC-coupled applications (see *Figure 8*), only one supply ( $V_S$ ) is needed. The vertical position of the scanning cannot be adjusted with input bias (for that purpose, usually some current is injected or sunk with a resistor in the low side of the yoke).

**Figure 8. AC-coupled application**

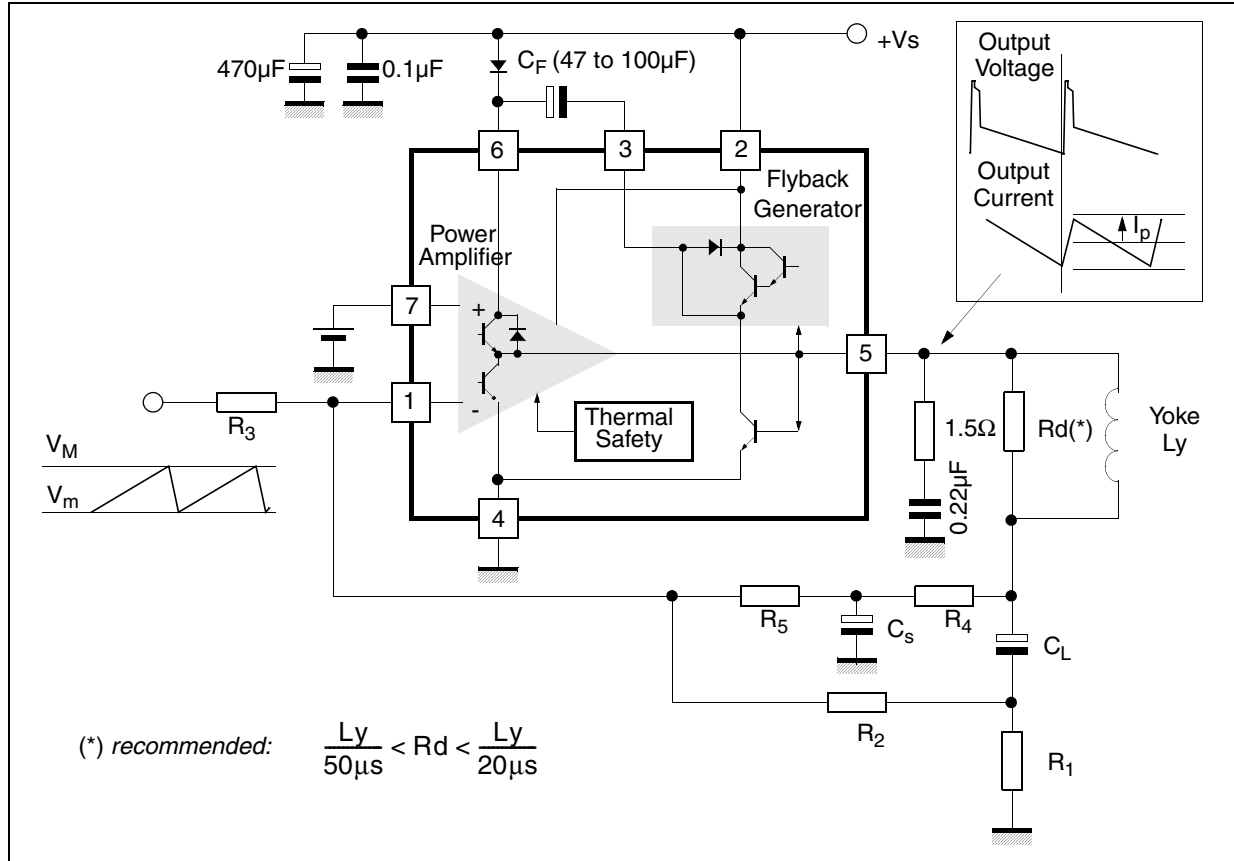

### 4.2.1 Application hints

Gain is defined as in the previous case:

$$I_p = \frac{V_M - V_m}{2} \times \frac{R_2}{R_1 \times R_3}$$

Choose  $R_1$  then either  $R_2$  or  $R_3$ . For good output centering,  $V_7$  must fulfill the following equation:

$$\frac{\frac{V_S}{2} - V_7}{R_4 + R_5} = \frac{V_7 - \frac{V_M + V_m}{2}}{R_3} + \frac{V_7}{R_2}$$

or

$$V_7 \times \left( \frac{1}{R_3} + \frac{1}{R_2} + \frac{1}{R_4 + R_5} \right) = \left( \frac{V_S}{2(R_4 + R_5)} + \frac{V_M + V_m}{2 \times R_3} \right)$$

C<sub>S</sub> performs an integration of the parabolic signal on C<sub>L</sub>, therefore the amount of S correction is set by the combination of C<sub>L</sub> and C<sub>S</sub>.

### 4.3 Application with differential-output drivers

Certain driver ICs provide the ramp signal in differential form, as two current sources i<sub>+</sub> and i<sub>-</sub> with opposite variations.

Figure 9. Using a differential-output driver

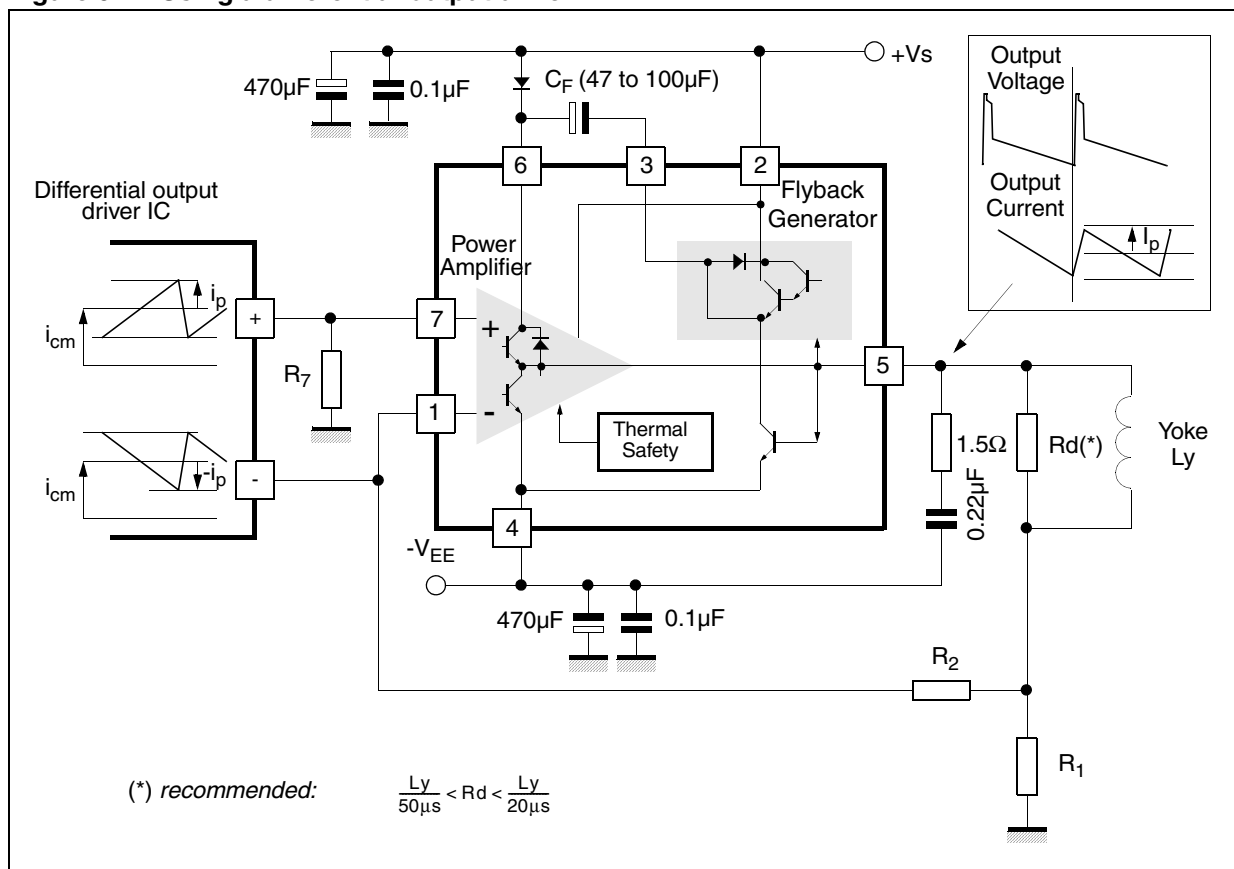

Some definitions:

- i<sub>cm</sub> is the common-mode current:  $i_{cm} = \frac{1}{2}(i_+ + i_-)$
- at peak of signal, i<sub>+</sub> = i<sub>cm</sub> + i<sub>p</sub> and i<sub>-</sub> = i<sub>cm</sub> - i<sub>p</sub>, therefore the peak differential signal is i<sub>p</sub> - (-i<sub>p</sub>) = 2 i<sub>p</sub>, and the peak-peak differential signal, 4i<sub>p</sub>.

The application is described in Figure 9 with DC yoke coupling. The calculations still rely on the fact that V<sub>1</sub> remains equal to V<sub>7</sub>.

### 4.3.1 Centering

When idle, both driver outputs provide  $i_{cm}$  and the yoke current should be null ( $R_1$  is negligible), hence:

$$i_{cm} \cdot R_7 = i_{cm} \cdot R_2 \quad \text{therefore} \quad R_7 = R_2$$

### 4.3.2 Peak current

Scanning current should be  $I_p$  when positive and negative driver outputs provide respectively  $i_{cm} - i$  and  $i_{cm} + i$ , therefore

$$(i_{cm} - i) \cdot R_7 = I_p \cdot R_1 + (i_{cm} + i) \cdot R_2$$

and since  $R_7 = R_2$

$$\frac{I_p}{i} = -\frac{2R_7}{R_1}$$

Choose  $R_1$  in the  $1\Omega$  range, the value of  $R_2 = R_7$  follows. Remember that  $i$  is one-quarter of driver peak-peak differential signal! Also check that the voltages on the driver outputs remain inside allowed range.

**Example:**

for  $i_{cm} = 0.4\text{mA}$ ,  $i = 0.2\text{mA}$  (corresponding to  $0.8\text{mA}$  of peak-peak differential current),  
 $I_p = 1\text{A}$

Choose  $R_1 = 0.75\Omega$  it follows  $R_2 = R_7 = 1.875\text{k}\Omega$

### 4.3.3 Ripple rejection

Make sure to connect  $R_7$  directly to the ground side of  $R_1$ .

### 4.3.4 Secondary breakdown diagrams

Figure 10. Output transistor safe operating area (SOA) for secondary breakdown

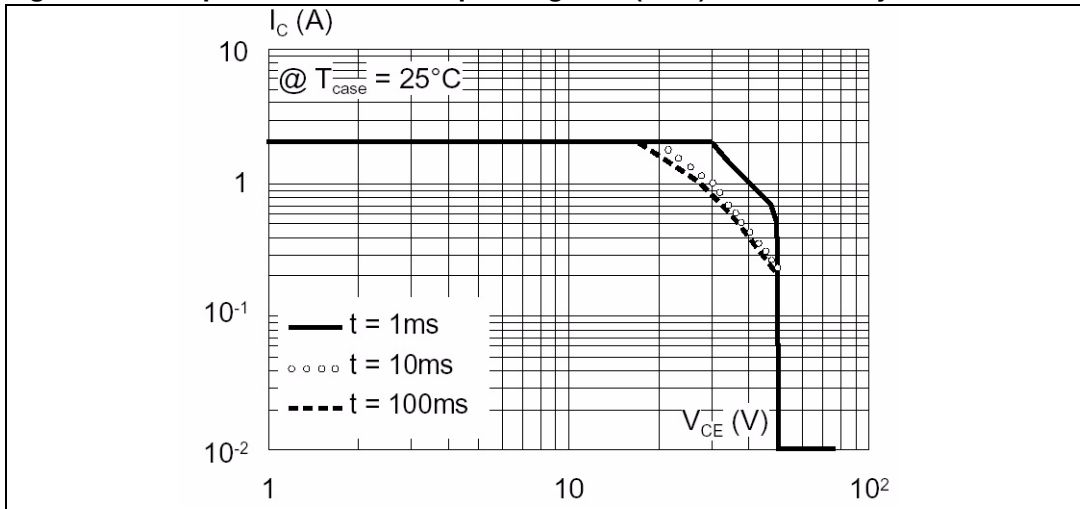

The diagram has been arbitrarily limited to max I0 (2A).

Figure 11. Secondary breakdown temperature derating curve (ISB = secondary breakdown current)

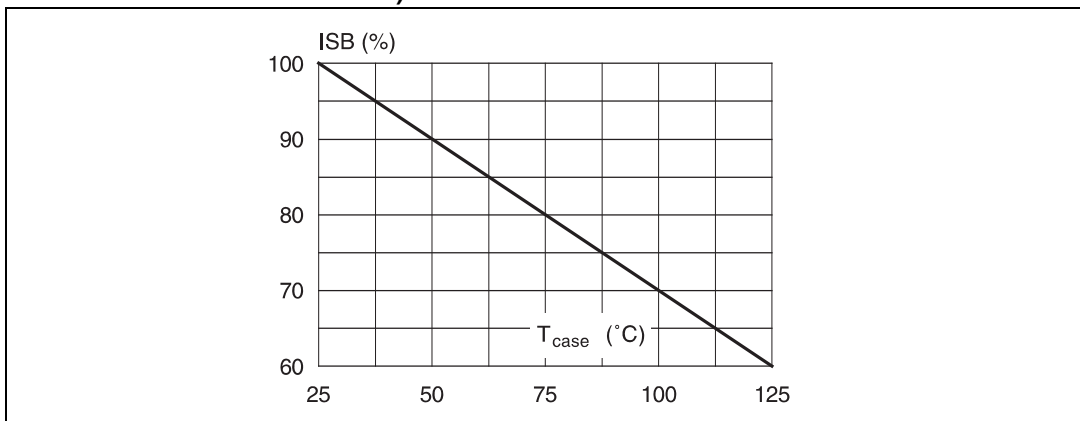

## 5 Mounting instructions

The power dissipated in the circuit is removed by adding an external heatsink. With the Heptawatt package, the heatsink is simply attached with a screw or a compression spring (clip).

A layer of silicon grease inserted between heatsink and package optimizes thermal contact. In DC-coupled applications we recommend to use a silicone tape between the device tab and the heatsink to electrically isolate the tab.

**Figure 12. Mounting examples**

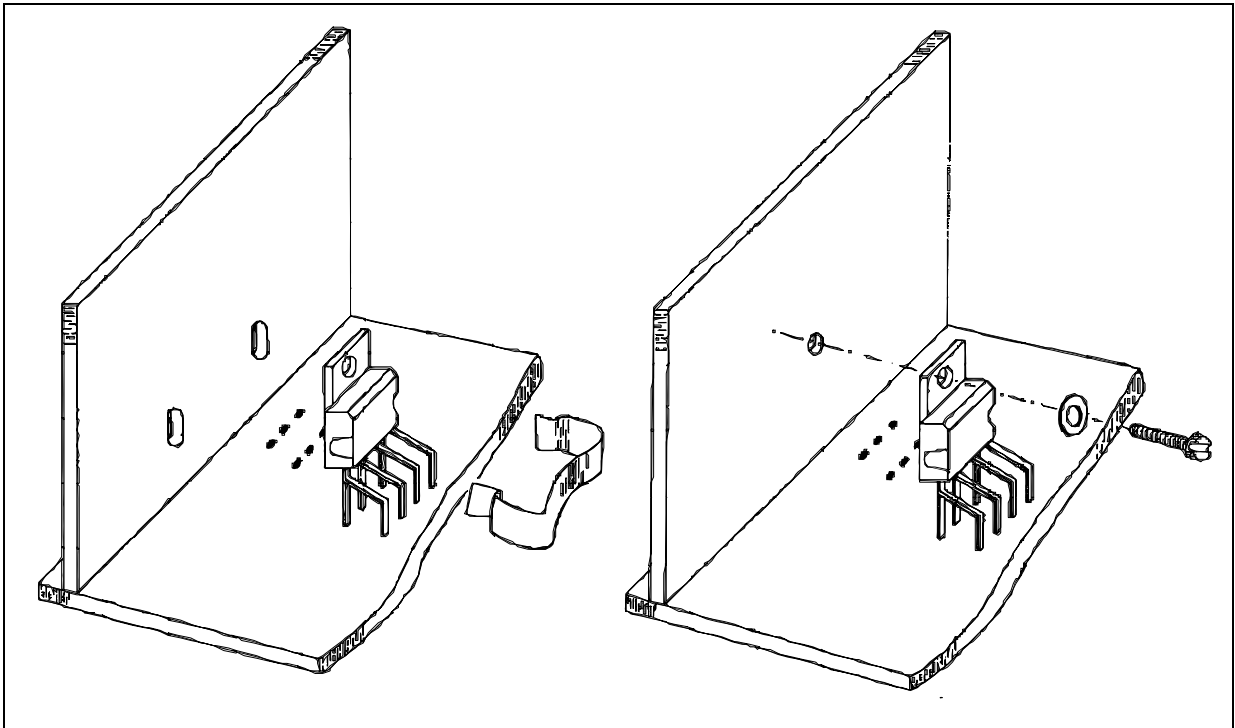

## 6 Pin configuration

Figure 13. Pins 1 and 7

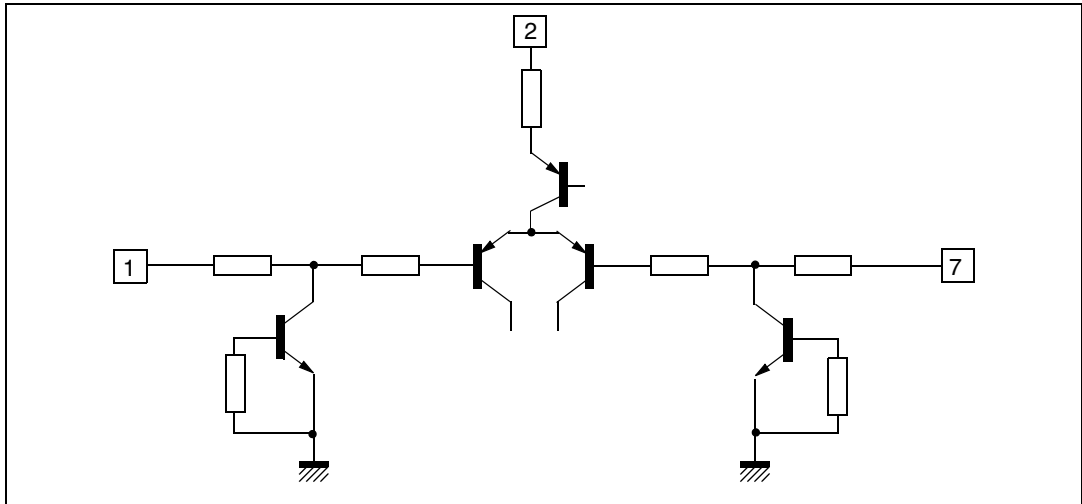
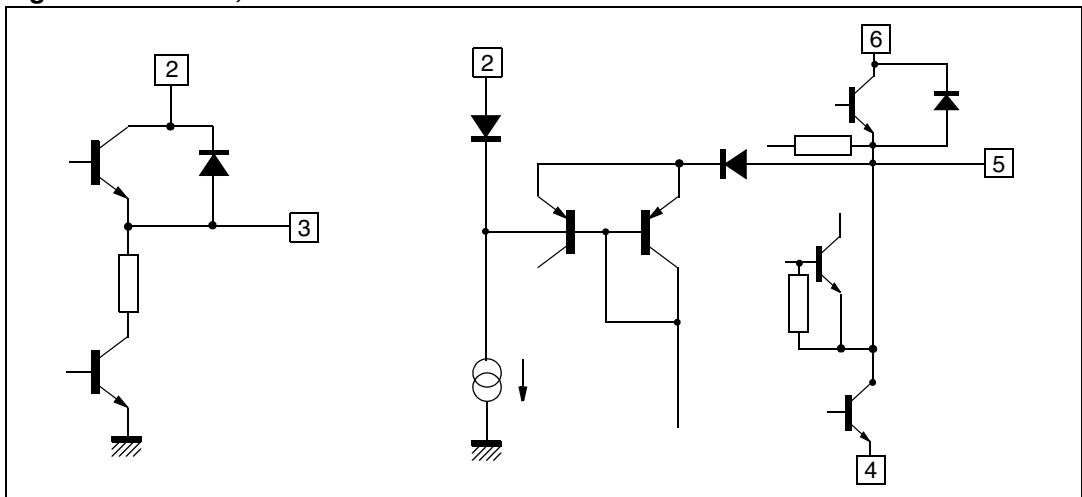

Figure 14. Pins 3, 5 and 6



## 7 Package mechanical data

Figure 15. 7-pin Heptawatt package

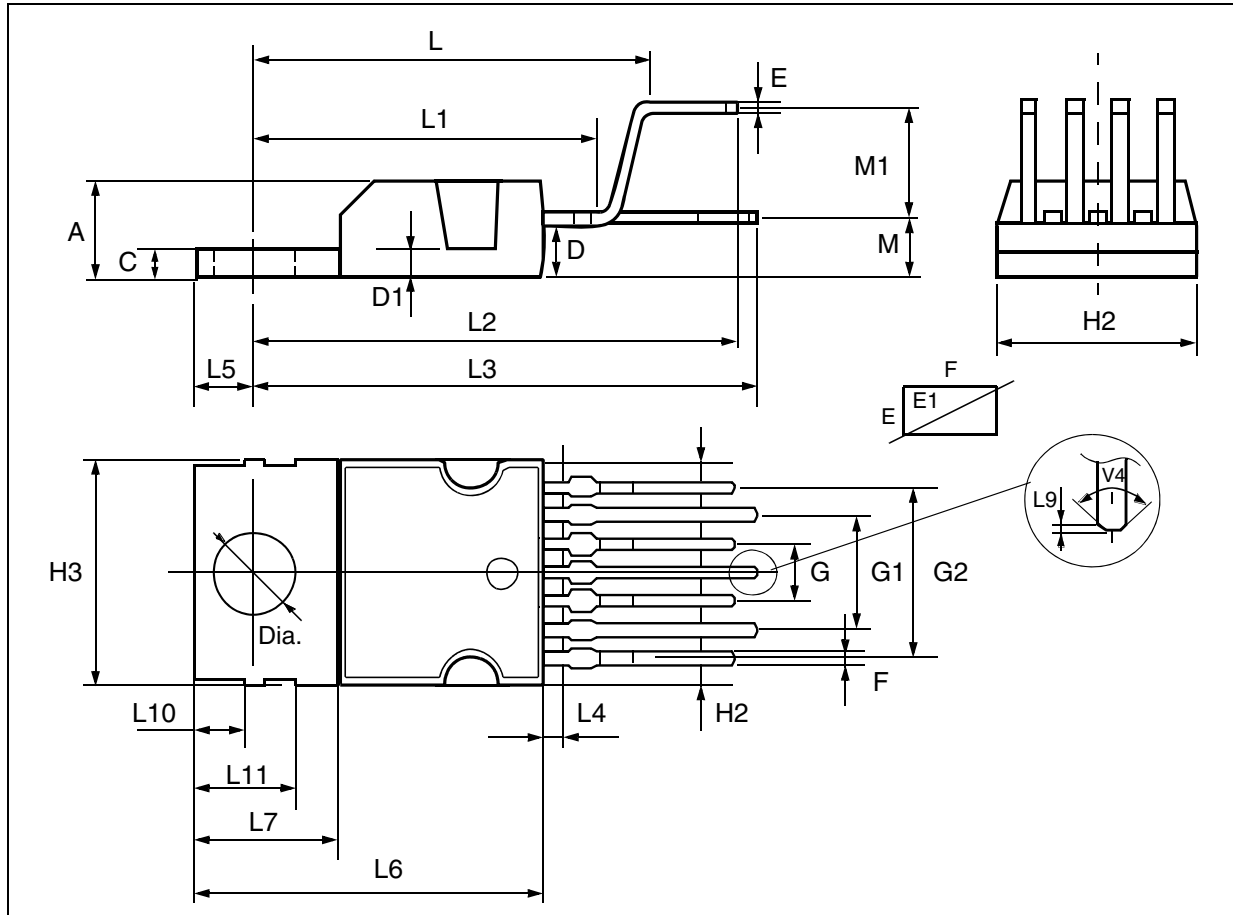

Table 4. Heptawatt package

Dim.	mm			inches		
	Min.	Typ.	Max.	Min.	Typ.	Max.
A			4.8			0.189
C			1.37			0.054
D	2.40		2.80	0.094		0.110
D1	1.20		1.35	0.047		0.053
E	0.35		0.55	0.014		0.022
E1	0.70		0.97	0.028		0.038
F	0.60		0.80	0.024		0.031



Table 4. Heptawatt package (continued)

Dim.	mm			inches		
<b>G</b>	2.34	2.54	2.74	0.095	0.100	0.105
<b>G1</b>	4.88	5.08	5.28	0.193	0.200	0.205
<b>G2</b>	7.42	7.62	7.82	0.295	0.300	0.307
<b>H2</b>			10.40			0.409
<b>H3</b>	10.05		10.40	0.396		0.409
<b>L</b>	16.70	16.90	17.10	0.657	0.668	0.673
<b>L1</b>		14.92			0.587	
<b>L2</b>	21.24	21.54	21.84	0.386	0.848	0.860
<b>L3</b>	22.27	22.52	22.77	0.877	0.891	0.896
<b>L4</b>			1.29			0.051
<b>L5</b>	2.60	2.80	3.00	0.102	0.110	0.118
<b>L6</b>	15.10	15.50	15.80	0.594	0.610	0.622
<b>L7</b>	6.00	6.35	6.60	0.0236	0.250	0.260
<b>L9</b>		0.20			0.008	
<b>L10</b>	2.10		2.70	0.082		0.106
<b>L11</b>	4.30		4.80	0.169		0.190
<b>M</b>	2.55	2.80	3.05	0.100	0.110	0.120
<b>M1</b>	4.83	5.08	5.33	0.190	0.200	0.210
<b>V4</b>	40 (Typ.)					
<b>Dia.</b>	3.65		3.85	0.144		0.152

## 7.1 Lead-free packaging

To meet environmental requirements, ST offers these devices in ECOPACK® packages. These packages have a lead-free second level interconnect. The category of second level interconnect is marked on the package and on the inner box label, in compliance with JEDEC Standard JESD97. The maximum ratings related to soldering conditions are also marked on the inner box label.

ECOPACK is an ST trademark. ECOPACK specifications are available at: [www.st.com](http://www.st.com).

## 8 Revision history

**Table 5. Document revision history**

Date	Revision	Changes
August 2003	1	First issue.
November 2003	1.1	Datasheet status changed to preliminary data.
December 2003	1.2	Modification to <a href="#">Figure 13</a> .
June 2004	1.3	Datasheet status changed to datasheet.
February 2005	2	Updated <a href="#">Figure 9</a> .
March 2005	3	Status changed to datasheet.
13-Nov-2008	4	<a href="#">Section 7.1</a> added, new template applied.

**Please Read Carefully:**

Information in this document is provided solely in connection with ST products. STMicroelectronics NV and its subsidiaries ("ST") reserve the right to make changes, corrections, modifications or improvements, to this document, and the products and services described herein at any time, without notice.

All ST products are sold pursuant to ST's terms and conditions of sale.

Purchasers are solely responsible for the choice, selection and use of the ST products and services described herein, and ST assumes no liability whatsoever relating to the choice, selection or use of the ST products and services described herein.

No license, express or implied, by estoppel or otherwise, to any intellectual property rights is granted under this document. If any part of this document refers to any third party products or services it shall not be deemed a license grant by ST for the use of such third party products or services, or any intellectual property contained therein or considered as a warranty covering the use in any manner whatsoever of such third party products or services or any intellectual property contained therein.

**UNLESS OTHERWISE SET FORTH IN ST'S TERMS AND CONDITIONS OF SALE ST DISCLAIMS ANY EXPRESS OR IMPLIED WARRANTY WITH RESPECT TO THE USE AND/OR SALE OF ST PRODUCTS INCLUDING WITHOUT LIMITATION IMPLIED WARRANTIES OF MERCHANTABILITY, FITNESS FOR A PARTICULAR PURPOSE (AND THEIR EQUIVALENTS UNDER THE LAWS OF ANY JURISDICTION), OR INFRINGEMENT OF ANY PATENT, COPYRIGHT OR OTHER INTELLECTUAL PROPERTY RIGHT.**

**UNLESS EXPRESSLY APPROVED IN WRITING BY AN AUTHORIZED ST REPRESENTATIVE, ST PRODUCTS ARE NOT RECOMMENDED, AUTHORIZED OR WARRANTED FOR USE IN MILITARY, AIR CRAFT, SPACE, LIFE SAVING, OR LIFE SUSTAINING APPLICATIONS, NOR IN PRODUCTS OR SYSTEMS WHERE FAILURE OR MALFUNCTION MAY RESULT IN PERSONAL INJURY, DEATH, OR SEVERE PROPERTY OR ENVIRONMENTAL DAMAGE. ST PRODUCTS WHICH ARE NOT SPECIFIED AS "AUTOMOTIVE GRADE" MAY ONLY BE USED IN AUTOMOTIVE APPLICATIONS AT USER'S OWN RISK.**

Resale of ST products with provisions different from the statements and/or technical features set forth in this document shall immediately void any warranty granted by ST for the ST product or service described herein and shall not create or extend in any manner whatsoever, any liability of ST.

ST and the ST logo are trademarks or registered trademarks of ST in various countries.

Information in this document supersedes and replaces all information previously supplied.

The ST logo is a registered trademark of STMicroelectronics. All other names are the property of their respective owners.

© 2008 STMicroelectronics - All rights reserved

STMicroelectronics group of companies

Australia - Belgium - Brazil - Canada - China - Czech Republic - Finland - France - Germany - Hong Kong - India - Israel - Italy - Japan - Malaysia - Malta - Morocco - Singapore - Spain - Sweden - Switzerland - United Kingdom - United States of America

[www.st.com](http://www.st.com)