

PAL DECODER

GENERAL DESCRIPTION

The TDA3565 PAL decoder contains all the functions required for PAL signal decoding and colour matrixing and is contained within an 18-pin package. The oscillator, a.c.c. detector and burst phase detector each have single-pin outputs and the coupling capacitor for the luminance input at pin 8 doubles as a storage capacitor for the black level clamping circuit. Black level clamping of the three colour channels is performed using feedback proportional to the red channel black level. This feedback (variable with the brightness control) controls the input level of the luminance amplifier and therefore the clamping levels of all three colour signal outputs.

QUICK REFERENCE DATA

Supply voltage	$V_p = V_{1-17}$	typ.	12 V
Supply current	$I_p = I_1$	typ.	85 mA
Luminance input signal (peak-to-peak value)	$V_{8-17(p-p)}$	typ.	0,45 V
Chrominance input signal (peak-to-peak value)	$V_{3-17(p-p)}$	typ.	550 mV
RGB output signal amplitudes (peak-to-peak value) at nominal luminance and contrast	$V_{10,11,12-17(p-p)}$	typ.	5 V
Contrast control range			-17 to +3 dB
Saturation control range		>	50 dB
A.C.C. control range		>	30 dB
Level at which RGB blanking is activated	V_{7-17}	typ.	1,5 V
Level at which burst gate/clamping pulse are separated	V_{7-17}	typ.	7 V

PACKAGE OUTLINE

18-lead DIL; plastic (SOT102).

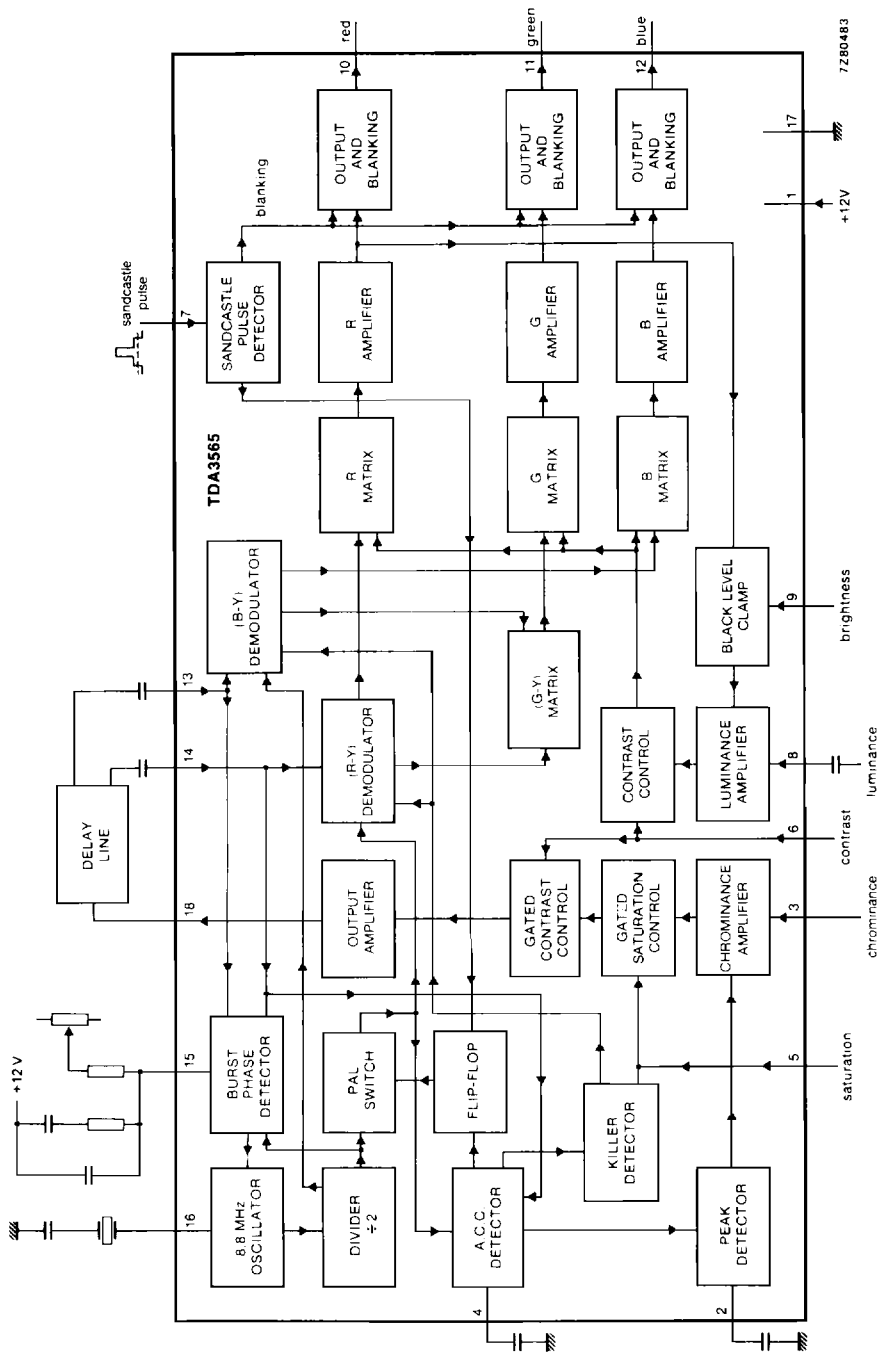

Fig. 1 Block diagram.

RATINGS

Limiting values in accordance with the Absolute Maximum System (IEC 134)

Supply voltage (pin 1)	$V_P = V_{1-17}$	max.	13,2 V
Total power dissipation	P_{tot}	max.	1,7 W
Operating ambient temperature range	T_{amb}		-25 to +65 °C
Storage temperature range	T_{stg}		-25 to +150 °C

THERMAL RESISTANCE

From junction to ambient (in free air)	$R_{th\ j-a}$	max.	50 K/W
--	---------------	------	--------

CHARACTERISTICS $V_P = V_{1-17} = 12\text{ V}$; $T_{amb} = 25\text{ °C}$ unless otherwise specified

parameter	symbol	min.	typ.	max.	unit
Supply (pin 1)					
Supply voltage	V_{1-17}	9,0	12,0	13,2	V
Supply current	I_1	—	85	—	mA
Total power dissipation	P_{tot}	—	1,0	—	W
Luminance amplifier					
Input signal amplitude (note 1) (peak-to-peak value)	$V_{8-17(p-p)}$	—	0,45	—	V
Input level before clipping occurs*	$V_{8-17(p-p)}$	—	—	0,7	V
Input current at $V_{8-17} = 2\text{ V}$; clamp not active	I_8	—	0,15	1,0	μA
Contrast control range (Fig. 2)		—	-17 to +3	—	dB
Input current when peak white limiter is active ($V_{6-17} = 2,5\text{ V}$)	I_8	—	5,5	—	mA
Input resistance $V_{6-17} > 6\text{ V}$	R_i	1,4	2,0	2,6	$\text{k}\Omega$
Chrominance amplifier					
Input signal amplitude (note 2)	$V_{3-17(p-p)}$	55	550	1100	mV
Minimum burst signal amplitude within the control range (peak-peak)		30	—	—	mV
Input impedance	Z_{3-17}	—	8,0	—	$\text{k}\Omega$
Input capacitance	C_{3-17}	—	4,0	6,0	pF
A.C.C. control range		30	—	—	dB
Change of burst signal at output over whole a.c.c. control range		—	—	1	dB
Amplification pin 3 to pin 18 at nominal contrast/saturation (note 3)		32	—	—	dB

* At nominal contrast and nominal brightness.

CHARACTERISTICS (continued)

parameter	symbol	min.	typ.	max.	unit
Chrominance amplifier (continued)					
Chroma to burst ratio (note 3)		—	3,8	—	dB
Max. output voltage range (pin 18) $R_L = 2 \text{ k}\Omega$		4,0	4,5	—	V
Chrominance amplifier distortion at $V_{8-17(p-p)} = 2 \text{ V}$ (output) up to $V_{3-17(p-p)} = 1 \text{ V}$ (input)	d _{g-3}	—	3,0	5,0	%
Frequency response between 0 and 5 MHz		—	—	-2	dB
Saturation control range (Fig. 3)		50	—	—	dB
Saturation control input current at $V_{5-17} < 6 \text{ V}$	I ₅	—	1	20	μA
Input impedance for V_5 between 6 and 10 V	Z _i	1,4	2,0	2,6	k Ω
Input impedance when colour killer is active	Z _i	1,4	2,0	2,6	k Ω
Input impedance for $V_5 > 10 \text{ V}$ (adjustment procedure)	Z _i	0,7	1,0	1,3	k Ω
Tracking between luminance and chrominance over 10 dB of contrast control range		—	—	2	dB
Cross coupling between luminance and chrominance amplifiers (note 4)		—	—	-46	dB
Signal-to-noise ratio at nominal input signal (note 5)	S/N	56	—	—	dB
Burst phase shift with respect to chrominance at nominal contrast/saturation (note 3)	$\Delta\varphi$	—	—	± 5	deg
Chrominance amplifier output impedance	Z ₁₈₋₁₇	—	25	—	Ω
Output current (pin 18)	I ₁₈	—	—	10	mA
Reference part					
Phase-locked loop					
Catching range	Δf	500	700	—	Hz
Phase shift for $\pm 400 \text{ Hz}$ deviation of oscillator frequency	$\Delta\varphi$	—	—	5	deg
Oscillator					
Temperature coefficient of oscillator frequency	T _{Cosc}	—	2	3	Hz/K
Frequency deviation when supply voltage changes from 10 to 13,2 V	Δf_{osc}	—	200	300	Hz

parameter	symbol	min.	typ.	max.	unit
Input resistance	R ₁₆₋₁₇	250	290	330	Ω
Input capacitance	C ₁₆₋₁₇	—	—	10	pF
A.C.C. generation					
Voltage with nominal input signal	V ₄₋₁₇	—	5,0	—	V
Voltage without chrominance input	V ₄₋₁₇	—	2,5	—	V
Colour-off voltage	V ₄₋₁₇	—	3,2	—	V
Colour-on voltage	V ₄₋₁₇	—	3,5	—	V
Identification-on voltage	V ₄₋₁₇	—	2,5	—	V
Pin 2 voltage at nominal input signal	V ₂₋₁₇	—	5,1	—	V
Demodulator part					
Burst signal amplitude (peak-to-peak value) at pins 13 and 14 (note 6)	V _{13-17(p-p)} V _{14-17(p-p)}	—	80	—	mV
Input impedance of pins 13 or 14 to pin 17	Z _{13, 14-17}	—	1,0	—	kΩ
Ratios of demodulated signals with equal signal inputs to pins 13 and 14 and no luminance input signal:					
(B-Y)/(R-Y)	$\frac{V_{12-17}}{V_{10-17}}$	—	1,78±10%	—	
(G-Y)/(R-Y) (no (B-Y) signal)	$\frac{V_{11-17}}{V_{10-17}}$	—	-0,51±10%	—	
(G-Y)/(B-Y) (no (R-Y) signal)	$\frac{V_{11-17}}{V_{12-17}}$	—	-0,19±10%	—	
Frequency response between 0 and 1 MHz		—	—	-3	dB
Separation of colour difference channels		40	—	—	dB
Phase difference between (R-Y) signal and (R-Y) reference signal	Δφ	—	—	5	deg
Phase difference between (R-Y) and (B-Y) reference signals	Δφ	85	90	95	deg
RGB matrix and amplifiers					
Output signal amplitudes (peak-to-peak value) at nominal luminance signal and contrast inputs (black-white) (note 3)	V _{10-17(p-p)} V _{11-17(p-p)} V _{12-17(p-p)}	4,5	5,0	5,5	V
Red channel output amplitude (peak-to- peak value) at nominal contrast/satura- tion (note 3) and no luminance signal to (R-Y)	V _{10-17(p-p)}	3,7	5,25	7,4	V

CHARACTERISTICS (continued)

parameter	symbol	min.	typ.	max.	unit
Maximum peak white level (note 7)		9,0	9,3	9,6	V
Maximum output current	I _{10,11,12}	—	—	15	mA
Red channel black level output when brightness control V ₉₋₁₇ = 2 V	V ₁₀₋₁₇	—	2,7	—	V
Difference between black levels in R, G and B outputs		—	—	600	mV
Black level shift with picture content		—	—	40	mV
Brightness control voltage range	V ₉₋₁₇	see Fig. 3			
Brightness control input current at V ₉₋₁₇ = 2 V	I ₉	—	—	—50	μA
Variation of black level with temperature		—	+0,35	1,0	mV/K
Variation of black level with contrast control		—	10	100	mV
Relative spread between the three channel outputs		—	—	10	%
Relative variation in black level between the three channels during normal variations of contrast and supply voltage		—	0	20	mV
Differential drift of black level over a temperature range of 40 °C		—	0	20	mV
Blanking level at the three channel outputs		1,9	2,1	2,3	V
Difference in blanking level of the three channel outputs		—	0	—	mV
Differential drift of blanking levels over a temperature range of 40 °C		—	0	—	mV
Tracking of output black levels with variation of supply voltage	$\frac{\Delta V_{bl}}{V_{bl}} \times \frac{V_P}{\Delta V_P}$	—	1,1	—	
Signal-to-noise ratio of output signals (note 5)	S/N	62	—	—	dB
Residual 4,4 MHz component in output signals (peak-to-peak value)		—	25	50	mV
Residual 8,8 MHz and higher harmonic components in output signals (peak- to-peak value)		—	25	50	mV
Output impedance	Z _{10,11,12-17}	—	50	—	Ω
Frequency response of total luminance/ RGB amplifier circuits for 0 to 5 MHz		—	—	—3	dB

parameter	symbol	min.	typ.	max.	unit
Sandcastle pulse detector					
Level at which RGB blanking is activated	V7.17	1,0	1,5	2,0	V
Level at which burst gate and clamping pulse are separated	V7.17	6,5	7,0	7,5	V
Delay between black level clamping and burst gating pulse		—	0,4	—	μ s
Input current at:					
V7.17 = 0 to 1 V	I7	—	—	—1	mA
V7.17 = 1 to 8,5 V	I7	—	20	40	μ A
V7.17 = 8,5 to 12 V	I7	—	—	2	mA

Notes to the characteristics

1. Signal with negative-going sync pulse, amplitude includes sync pulse amplitude.
2. The signal indicated is for a colour bar with 75% saturation, so the chroma burst ratio of 2,2 : 1.
3. Nominal contrast is defined as (maximum contrast -3 dB) and nominal saturation is (maximum saturation -12 dB).
4. Cross coupling is measured under the following condition; input signals nominal and contrast/saturation such that nominal output signals are obtained. The signals at the output at which no signal should be available must be compared with the nominal signal at that output.
5. The signal-to-noise ratio is specified as peak-to-peak signal with respect to r.m.s. noise.
6. These signal amplitudes are determined by the a.c.c. circuit of the reference part.
7. When this level is exceeded the amplitude of the output signal is reduced via a discharge of the capacitor at pin 6 (contrast control). The discharge current is 5,5 mA.

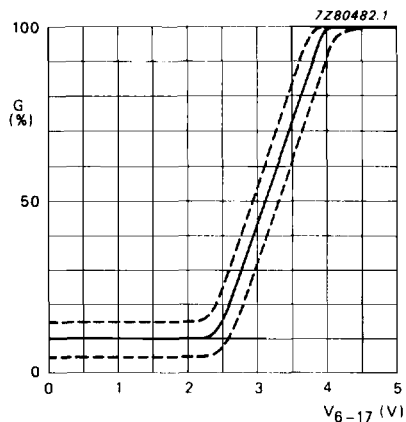

Fig. 2 Luminance contrast control voltage range.

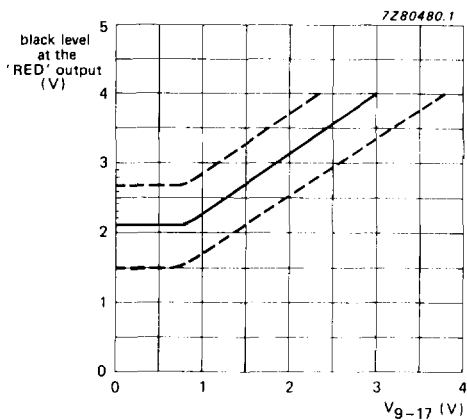

Fig. 3 Brightness control voltage range.

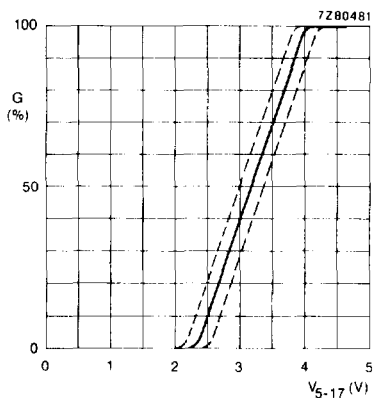

Fig. 4 Saturation control voltage range.

APPLICATION INFORMATION

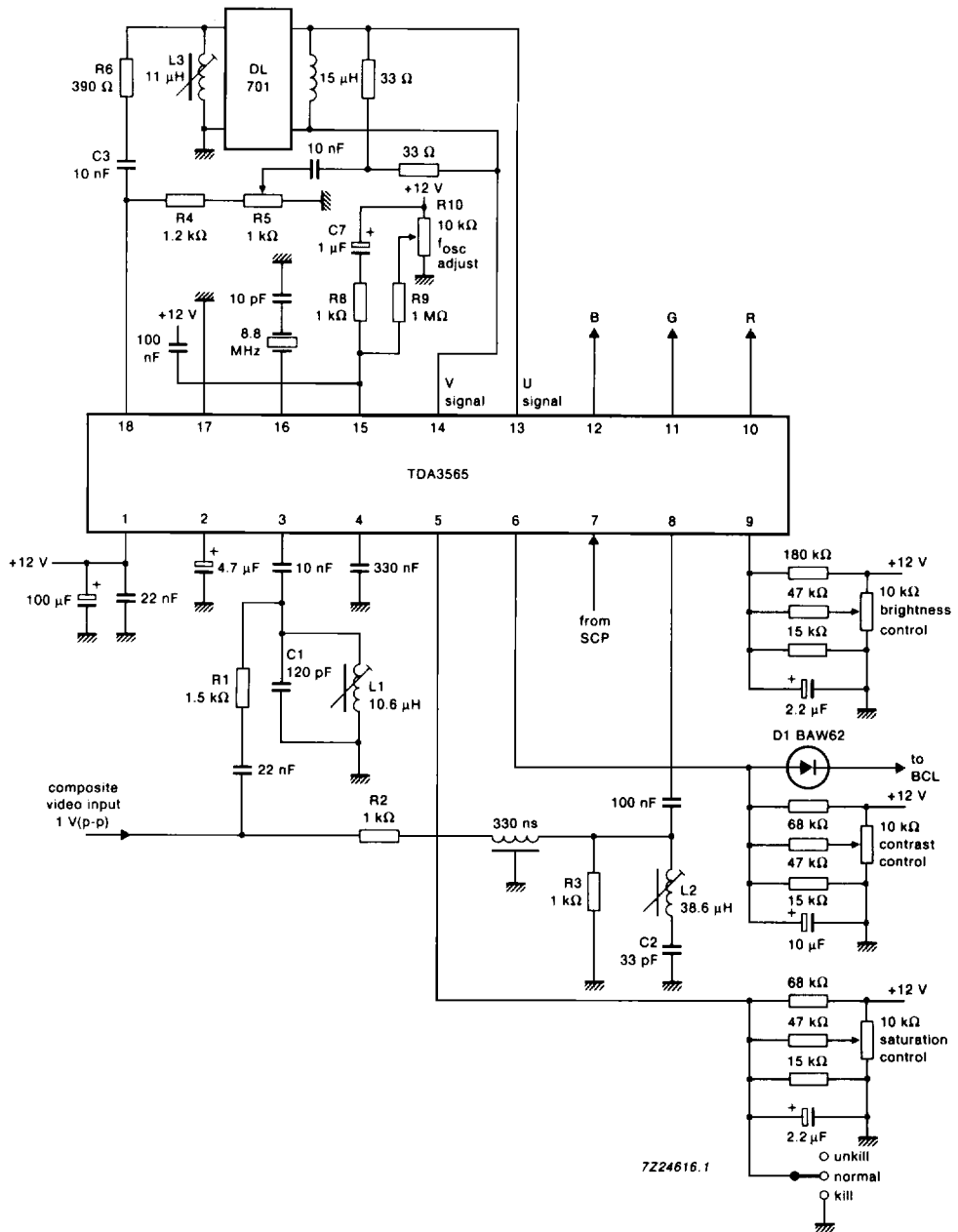

Fig. 5 Application diagram