

PAL/NTSC DECODER

GENERAL DESCRIPTION

The TDA3566 is a monolithic integrated decoder for the PAL and/or NTSC colour television standards. It combines all functions required for the identification and demodulation of PAL/NTSC signals. Furthermore it contains a luminance amplifier, an RGB-matrix and amplifier. These amplifiers supply output signals up to 4 V peak-to-peak (picture information) enabling direct drive of the discrete output stages. The circuit also contains separate inputs for data insertion, analogue as well as digital, which can be used for text display systems (e.g. Teletext/broadcast antiope), channel number display, etc.

Features

- A black-current stabilizer which controls the black-currents of the three electron-guns to a level low enough to omit the black-level adjustment
- Contrast control of inserted RGB signals
- No black-level disturbance when non-synchronized external RGB signals are available on the inputs
- NTSC capability with hue control

QUICK REFERENCE DATA

Supply voltage (pin 1)	$V_P = V_{1-27}$	typ.	12 V
Supply current (pin 1)	$I_P = I_1$	typ.	80 mA
Luminance amplifier (pin 8)			
Input voltage (peak-to-peak value)	$V_{8-27(p-p)}$	typ.	450 mV
Contrast control range		typ.	20 dB
Chrominance amplifier (pin 4)			
Input voltage range (peak-to-peak value)	$V_{4-27(p-p)}$	40 to	1100 mV
Saturation control range		min.	50 dB
RGB matrix and amplifiers			
Output voltage at nominal luminance and contrast (peak-to-peak value)	$V_{13, 15, 17-27(p-p)}$	typ.	4 V
Data insertion			
Input signals (peak-to-peak value)	$V_{12, 14, 16-27(p-p)}$	typ.	1 V
Data blanking (pin 9)			
Input voltage for data insertion	V_{9-27}	min.	0,9 V
Sandcastle input (pin 7)			
Blanking input voltage	V_{7-27}	typ.	1,5 V
Burst gating and clamping input voltage	V_{7-27}	typ.	7 V

PACKAGE OUTLINE

28-lead DIL; plastic, with internal heat spreader (SOT117).

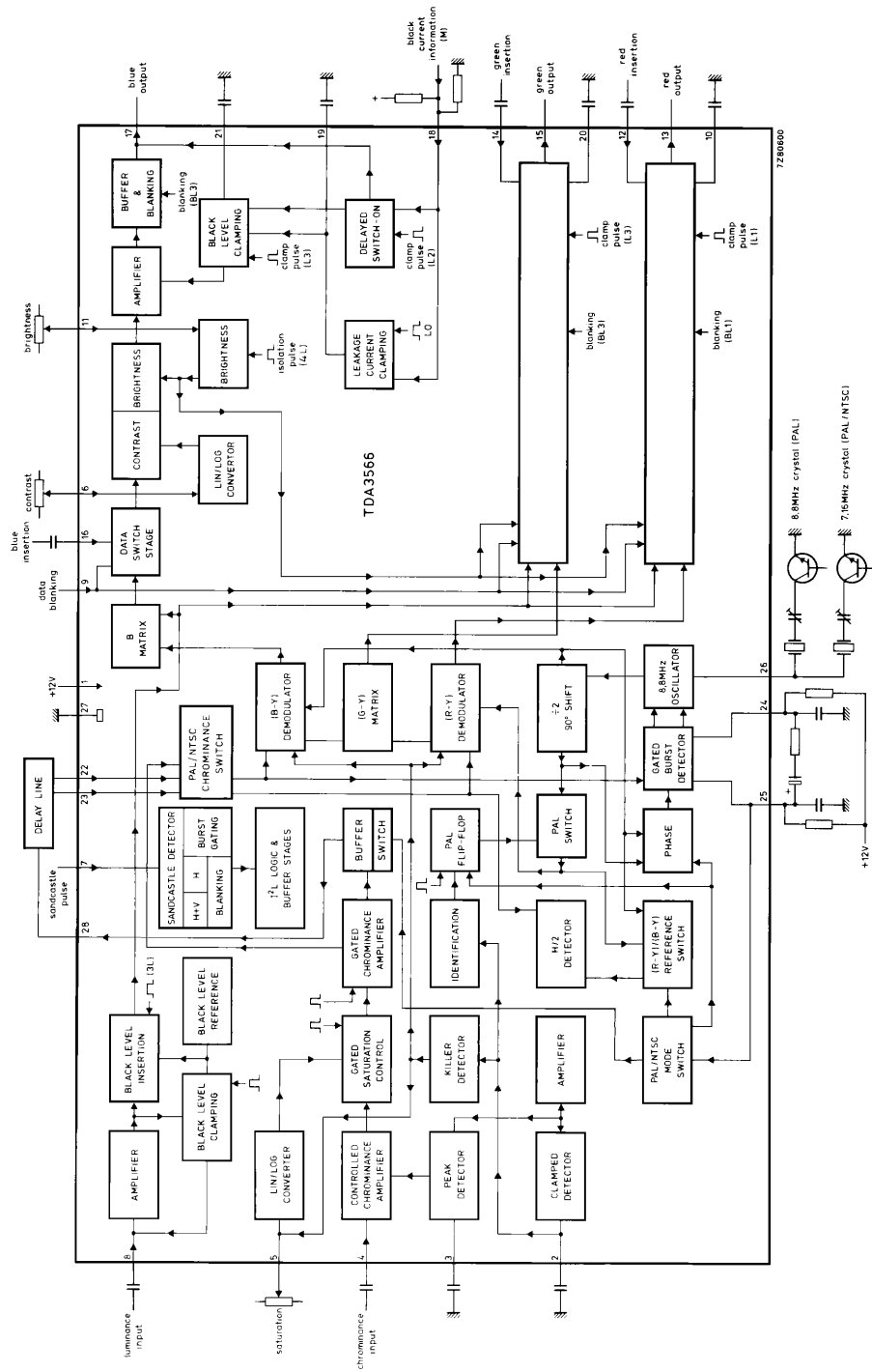

Fig. 1 Block diagram; for explanation of pulse mnemonics see Fig. 6.

FUNCTIONAL DESCRIPTION

The TDA3566 is a further development of the TDA3562A. It has the same pinning and almost the same application. The differences between the TDA3562A and the TDA3566 are as follows:

- The NTSC-application has largely been simplified. In the case of NTSC the chroma signal is now internally coupled to the demodulators, ACC and phase detectors. The chroma output signal (pin 28) is suppressed in this case. It follows that the external switches and filters which are needed for the TDA3562A are not needed for the TDA3566.
- Furthermore there is no difference between the amplitude of the colour output signals in the PAL or NTSC mode. The PAL/NTSC-switch and the hue control of the TDA3566 and the TDA3562A are identical.
- The switch-on and the switch-off behaviour of the TDA3566 has been improved. This has been obtained by suppressing the output signals during the switch-on and switch-off periods.
- The clamp capacitors connected to the pins 10, 20 and 21 can be reduced to 100 nF for the TDA3566. The clamp capacitors also receive a pre-bias voltage to avoid coloured background during switch-on.
- The crystal oscillator circuit has been changed to prevent parasitic oscillations on the third overtone of the crystal. This has the consequence that optimal tuning capacitance must be reduced to 10 pF.

Luminance amplifier

The luminance amplifier is voltage driven and requires an input signal of 450 mV peak-to-peak (positive video). The luminance delay line must be connected between the i.f. amplifier and the decoder. The input signal is a.c. coupled to the input (pin 8). After amplification, the black level at the output of the preamplifier is clamped to a fixed d.c. level by the black level clamping circuit. During three line periods after vertical blanking, the luminance signal is blanked out and the black level reference voltage is inserted by a switching circuit. This black level reference voltage is controlled via pin 11 (brightness). At the same time the RGB signals are clamped. Noise and residual signals have no influence during clamping thus simple internal clamping circuitry is used.

Chrominance amplifiers

The chrominance amplifier has an asymmetrical input. The input signal must be a.c. coupled (pin 4) and have a minimum amplitude of 40 mV peak-to-peak. The gain control stage has a control range in excess of 30 dB, the maximum input signal must not exceed 1,1 V peak-to-peak, otherwise clipping of the input signal will occur. From the gain control stage the chrominance signal is fed to the saturation control stage. Saturation is linear controlled via pin 5. The control voltage range is 2 to 4 V, the input impedance is high and the saturation control range is in excess of 50 dB. The burst signal is not affected by saturation control. The signal is then fed to a gated amplifier which has a 12 dB higher gain during the chrominance signal. As a result the signal at the output (pin 28) has a burst to chrominance ratio which is 6 dB lower than that of the input signal when the saturation control is set at -6 dB. The chrominance output signal is fed to the delay line and, after matrixing, is applied to the demodulator input pins (pins 22 and 23). These signals are fed to the burst phase detector. In the case of NTSC the chroma signal is internally coupled to the demodulators, ACC and phase detector.

FUNCTIONAL DESCRIPTION (continued)**Oscillator and identification circuit**

The burst phase detector is gated with the narrow part of the sandcastle pulse (pin 7). In the detector the (R-Y) and (B-Y) signals are added to provide the composite burst signal again. This composite signal is compared with the oscillator signal divided-by-2 ((R-Y) reference signal). The control voltage is available at pins 24 and 25, and is also applied to the 8,8 MHz oscillator. The 4,4 MHz signal is obtained via the divide-by-2 circuit, which generates both the (B-Y) and (R-Y) reference signals and provides a 90° phase shift between them.

The flip-flop is driven by pulses obtained from the sandcastle detector. For the identification of the phase at PAL mode, the (R-Y) reference signal coming from the PAL switch, is compared to the vertical signal (R-Y) of the PAL delay line. This is carried out in the H/2 detector, which is gated during burst. When the phase is incorrect, the flip-flop gets a reset from the identification circuit. When the phase is correct, the output voltage of the H/2 detector is directly related to the burst amplitude so that this voltage can be used for the a.c.c. To avoid 'blooming-up' of the picture under weak input signal conditions the a.c.c. voltage is generated by peak detection of the H/2 detector output signal.

The killer and identification circuits get their information from a gated output signal of the H/2 detector. Killing is obtained via the saturation control stage and the demodulators to obtain good suppression. The time constant of the saturation control (pin 5) provides a delayed switch-on after killing.

Adjustment of the oscillator is achieved by variation of the burst phase detector load resistance between pins 24 and 25 (see Fig. 7). With this application the trimmer capacitor in series with the 8,8 MHz crystal (pin 26) can be replaced by a fixed value capacitor to compensate for unbalance of the phase detector.

Demodulator

The (R-Y) and (B-Y) demodulators are driven by the colour difference signals from the delay-line matrix circuit and the reference signals from the 8,8 MHz divider circuit. The (R-Y) reference signal is fed via the PAL-switch. The output signals are fed to the R and B matrix circuits and to the (G-Y) matrix to provide the (G-Y) signal which is applied to the G-matrix. The demodulation circuits are killed and blanked by by-passing the input signals.

NTSC mode

The NTSC mode is switched on when the voltage at the burst phase detector outputs (pins 24 and 25) is adjusted below 9 V. To ensure reliable application the phase detector load resistors are external. When the TDA3566 is used only for PAL these two 33 kΩ resistors must be connected to + 12 V (see Fig. 7). For PAL/NTSC application the value of each resistor must be reduced to 10 kΩ and connected to the slider of a potentiometer (see Fig. 8). The switching transistor brings the voltage at pins 24 and 25 below 9 V which switches the circuit to the NTSC mode. The position of the PAL flip-flop ensures that the correct phase of the (R-Y) reference signal is supplied to the (R-Y) demodulator. The drive to the H/2 detector is now provided by the (B-Y) reference signal. (In the PAL mode it is driven by the (R-Y) reference signal.)

Hue control is realized by changing the phase of the reference drive to the burst phase detector. This is achieved by varying the voltage at pins 24 and 25 between 7,5 V and 8,5 V, nominal position 8,0 V. The hue control characteristic is shown in Fig. 5.

RGB matrix and amplifiers

The three matrix and amplifier circuits are identical and only one circuit will be described.

The luminance and the colour difference signals are added in the matrix circuit to obtain the colour signal, which is then fed to the contrast control stage. The contrast control voltage is supplied to pin 6 (high-input impedance). The control range is +3 dB to -17 dB nominal. The relationship between the control voltage and the gain is linear (see Fig. 2).

During the 3-line period after blanking a pulse is inserted at the output of the contrast control stage. The amplitude of this pulse is varied by a control voltage at pin 11. This applies a variable offset to the normal black level, thus providing brightness control. The brightness control range is 1 V to 3 V.

While this offset level is present, the 'black-current' input impedance (pin 18) is high and the internal clamp circuit is activated. The clamp circuit then compares the reference voltage at pin 19 with the voltage developed across the external resistor network R_A and R_B (pin 18) which is provided by picture tube beam current. The output of the comparator is stored in capacitors connected from pins 10, 20 and 21 to ground which controls the black level at the output. The reference voltage is composed by the resistor divider network and the leakage current of the picture tube into this bleeder. During vertical blanking, this voltage is stored in the capacitor connected to pin 19, which ensures that the leakage current of the CRT does not influence the black current measurement.

The RGB output signals can never exceed a level of 10 V. When the signal tends to exceed this level the output signal is clipped. The black level at the outputs (pins 13, 15 and 17) will be about 3 V. This level depends on the spread of the guns of the picture tube. If a beam current stabilizer is not used it is possible to stabilize the black levels at the outputs, which in this application must be connected to the black current measuring input (pin 18) via a resistor network.

Data insertion

Each colour amplifier has a separate input for data insertion. A 1 V peak-to-peak input signal provides a 4 V peak-to-peak output signal. To avoid the 'black-level' of the inserted signal differing from the black level of the normal video signal, the data is clamped to the black level of the luminance signal. Therefore a.c. coupling is required for the data inputs.

To avoid a disturbance of the blanking level due to the clamping circuit, the source impedance of the driver circuit must not exceed 150 Ω .

The data insertion circuit is activated by the data blanking input (pin 9). When the voltage at this pin exceeds a level of 0,9 V, the RGB matrix circuits are switched off and the data amplifiers are switched on. To avoid coloured edges, the data blanking switching time is short.

The amplitude of the data output signals is controlled by the contrast control at pin 6. The black level is equal to the video black level and can be varied between 2 and 4 V (nominal condition) by the brightness control voltage at pin 11.

Non-synchronized data signals do not disturb the black level of the internal signals.

Blanking of RGB and data signals

Both the RGB and data signals can be blanked via the sandcastle input (pin 7). A slicing level of 1,5 V is used for this blanking function, so that the wide part of the sandcastle pulse is separated from the remainder of the pulse. During blanking a level of +1 V is available at the output.

To prevent parasitic oscillations on the third overtone of the crystal the optimal tuning capacitance should be 10 pF.

RATINGS

Limiting values in accordance with Absolute Maximum System (IEC 134)

Supply voltage (pin 1)	$V_p = V_{1-27}$	max.	13,2 V
Total power dissipation	P_{tot}	max.	1,7 W
Storage temperature range	T_{stg}		-25 to + 150 °C
Operating ambient temperature range	T_{amb}		-25 to + 70 °C

THERMAL RESISTANCE

From junction to ambient (in free air)	$R_{th\ j-a}$	=	40 K/W
--	---------------	---	--------

CHARACTERISTICS

 $V_P = V_{1-27} = 12 \text{ V}$; $T_{\text{amb}} = 25 \text{ }^\circ\text{C}$; unless otherwise specified

DEVELOPMENT DATA

parameter	symbol	min.	typ.	max.	unit
Supply (pin 1)					
Supply voltage	$V_P = V_{1-27}$	10,8	12	13,2	V
Supply current	$I_P = I_1$	—	80	110	mA
Total power dissipation	P_{tot}	—	0,95	1,3	W
Luminance amplifier (pin 8)					
Input voltage (note 1) (peak-to-peak value)	$V_{8-27(p-p)}$	—	0,45	0,63	V
Input level before clipping	V_{8-27}	—	—	1,4	V
Input current	I_8	—	0,1	1	μA
Contrast control range (see Fig. 2)		-15	—	+ 5	dB
Input current contrast control	I_7	—	—	15	μA
Chrominance amplifier (pin 4)					
Input voltage (note 2) (peak-to-peak value)	$V_{4-27(p-p)}$	40	390	1100	mV
Input impedance (pin 4)	$ Z_{4-27} $	—	10	—	$\text{k}\Omega$
Input capacitance	C_{4-27}	—	—	6,5	pF
A.C.C. control range		30	—	—	dB
Change of the burst signal at the output over the whole control range	ΔV	—	—	1	dB
Gain at nominal contrast/saturation pin 4 to pin 28 (note 3)	G	34	—	—	dB
Chrominance to burst ratio at nominal saturation (notes 2 and 3) at pin 28		—	12	—	dB
Maximum output voltage range (peak-to-peak value); $R_L = 2 \text{ k}\Omega$	$V_{28-27(p-p)}$	4	5	—	V
Distortion of chrominance amplifier at $V_{28-27(p-p)} = 2 \text{ V}$ (output) up to $V_{4-27(p-p)} = 1 \text{ V}$ (input)	d	—	—	5	%
Frequency response between 0 and 5 MHz	α_{28-4}	—	—	-2	dB
Saturation control range (see Fig. 3)		50	—	—	dB
Input current saturation control (pin 5)	I_5	—	—	20	μA
Cross-coupling between luminance and chrominance amplifier (note 4)		—	—	-46	dB
Signal-to-noise ratio at nominal input signal (note 5)	S/N	56	—	—	dB

CHARACTERISTICS (continued)

parameter	symbol	min.	typ.	max.	unit
Chrominance amplifier (continued)					
Phase shift between burst and chrominance at nominal contrast/saturation	$\Delta\varphi$	—	—	± 5	deg
Output impedance of chrominance amplifier	$ Z_{28-27} $	—	10	—	Ω
Output current	I_{28}	—	—	15	mA
Reference part					
Phase-locked-loop catching range (note 6)	Δf	500	700	—	Hz
phase shift for ± 400 Hz deviation of f_{osc} (note 6)	$\Delta\varphi$	—	—	5	deg
Oscillator temperature coefficient of oscillator frequency (note 6)	TC_{osc}	—	-2	-3	Hz/K
frequency variation when supply voltage increases from 10 to 13,2 V (note 6)	Δf_{osc}	—	40	100	Hz
input resistance (pin 26)	R_{26-27}	280	400	520	Ω
input capacitance (pin 26)	C_{26-27}	—	—	10	pF
A.C.C. generation (pin 2)					
control voltage at nominal input signal	V_{2-27}	—	4,5	—	V
control voltage without chrominance input	V_{2-27}	—	2	—	V
colour-off voltage	V_{2-27}	—	2,8	—	V
colour-on voltage	V_{2-27}	—	3	—	V
identification-on voltage	V_{2-27}	—	1,7	—	V
change in burst amplitude with temperature		—	0,1	0,25	%/K
voltage at pin 3 at nominal input signal	V_{3-27}	—	5,1	—	V
Demodulator part					
Input burst signal amplitude (peak-to-peak value between pins 23 and 27 (note 7))	$V_{23-27}(p-p)$	68	80	95	mV
Input impedance between pins 22 or 23 and 27	$ Z_{22-27/23-27} $	0,7	1	1,3	k Ω
Ratio of demodulated signals (note 8)					
(B-Y)/(R-Y)	$\frac{V_{17-27}}{V_{13-27}}$	—	$1,78 \pm 10\%$	—	
(G-Y)/(R-Y); no (B-Y) signal	$\frac{V_{15-27}}{V_{13-27}}$	—	$-0,51 \pm 10\%$	—	
(G-Y)/(B-Y); no (R-Y) signal	$\frac{V_{15-27}}{V_{17-27}}$	—	$-0,19 \pm 10\%$	—	

parameter	symbol	min.	typ.	max.	unit
Demodulator part (continued)					
Frequency response between 0 and 1 MHz	α_{17}	—	—	—3	dB
Cross-talk between colour difference signals		40	—	—	dB
Phase difference between (R-Y) signal and (R-Y) reference signals	$\Delta\varphi$	—	—	5	deg
Phase difference between (R-Y) signal and (B-Y) reference signals	$\Delta\varphi$	85	90	95	deg
RGB matrix and amplifiers					
Output voltage (peak-to-peak value) at nominal luminance/contrast (black-to-white) (note 3)	$V_{13,15,17-27(p-p)}$	3,5	4	4,5	V
Output voltage at pin 13 (peak-to-peak value) at nominal contrast/saturation and no luminance signal to (R-Y)	$V_{13-27(p-p)}$	—	4,2	—	V
Maximum peak-white level	$V_{13,15,17 (m)}$	9,7	10	10,3	V
Available output current (pins 13, 15 17)	$I_{13,15,17}$	10	—	—	mA
Difference between black level and measuring level at the output for a brightness control voltage at pin 11 of 2 V (note 9)	$\Delta V_{13,15,17-27}$	—	0	—	V
Difference in black level between the three channels without black current stabilization (note 10)	ΔV	—	—	100	mV
Control range of black-current stabilization at $V_{b1} = 3$ V; $V_{11-17} = 2$ V		—	—	± 2	V
Black level shift with vision contents	ΔV	—	—	40	mV
Brightness control voltage range		see Fig. 4			
Brightness control input current	I_{11}	—	—	5	μ A
Variation of black level with temperature	$\Delta V/\Delta T$	—	0	—	mV/K
Variation of black level with contrast*	ΔV	—	—	100	mV
Relative spread between the R, G and B output signals		—	—	10	%
Relative black-level variation between the three channels during variation of contrast, brightness and supply voltage ($\pm 10\%$)*	ΔV	—	0	20	mV
Differential black-level drift over a temperature range of 40 °C	ΔV	—	0	20	mV
Blanking level at the RGB outputs	V_{bl}	—	0,95	1,1	V

* With respect to the measuring pulses.

CHARACTERISTICS (continued)

parameter	symbol	min.	typ.	max.	unit
RGB matrix and amplifiers (continued)					
Difference in blanking level of the three channels	V_{bl}	—	0	—	mV
Differential drift of the blanking levels over a temperature range of 40 °C	V_{bl}	—	0	10	mV
Tracking of output black level with supply voltage	$\frac{\Delta V_{bl}}{V_{bl}} \times \frac{V_P}{\Delta V_P}$	0,9	1	1,1	
Tracking of contrast control between the three channels over a control range at 10 dB		—	—	0,5	dB
Output signal during the clamp pulse (3L) after switch-on	V_O	7,5	—	—	V
Signal-to-noise ratio of output signals (note 5)	S/N	62	—	—	dB
Residual 4,4 MHz signal at RGB outputs (peak-to-peak value)	$V_{R(p-p)}$	—	—	50	mV
Residual 8,8 MHz signal and higher harmonics at the RGB outputs (peak-to-peak value)	$V_{R(p-p)}$	—	—	150	mV
Output impedance of RGB outputs	$ Z_{13,15,17-27} $	—	50	—	Ω
Frequency response of total luminance and RGB amplifier circuits for $f = 0$ to 9 MHz	α	—	-1	-3	dB
Current source of output stage	I_O	2	3	—	mA
Difference of black level at the three outputs at nominal brightness*	ΔV	—	—	10	mV
Tracking of brightness control		—	—	2	%
Signal insertion (pins 12, 14 and 16)					
Input signals (peak-to-peak value) for and RGB output voltage of 3.5 V (peak-to-peak) at nominal contrast	$V_{12,14,16-27(p-p)}$	0,9	1	1,1	V
Difference between the black levels of the RGB signals and the inserted signals at the output (note 11)	ΔV	—	—	100	mV
Output rise time	t_r	—	50	80	ns
Differential delay time for the three channels	t_d	—	0	40	ns
Input current	$I_{12,14,16}$	—	—	10	μA

* With respect to the measuring pulses.

DEVELOPMENT DATA

parameter	symbol	min.	typ.	max.	unit
Data blanking (pin 9)					
Input voltage for no data insertion	V ₉₋₂₇	—	—	0,4	V
Input voltage for data insertion	V ₉₋₂₇	0,9	—	—	V
Maximum input voltage	V _{9-27(m)}	—	—	3	V
Delay of data blanking	t _d	—	—	20	ns
Input resistance	R ₉₋₂₇	7	10	13	kΩ
Suppression of the internal RGB signals when V ₉₋₂₇ > 0,9 V		46	—	—	dB
Sandcastle input (pin 7)					
Level at which the RGB blanking is activated	V ₇₋₂₇	1	1,5	2	V
Level at which the horizontal pulses are separated	V ₇₋₂₇	3	3,5	4	V
Level at which burst gating and clamping pulse are separated	V ₇₋₂₇	6,5	7,0	7,5	V
Delay between black level clamping and burst gating pulse	t _d	—	0,6	—	μs
Input current					
at V ₇₋₂₇ = 0 to 1 V	-I ₇	—	—	1	mA
at V ₇₋₂₇ = 1 to 8,5 V	I ₇	—	—	50	μA
at V ₇₋₂₇ = 8,5 to 12 V	I ₇	—	—	2	mA
Black current stabilization (pin 18)					
Bias voltage (d.c.)	V ₁₈₋₂₇	3,5	5	7,0	V
Difference between input voltage for 'black' current and leakage current	ΔV	0,35	0,5	0,65	V
Input current during 'black' current	I ₁₈	—	—	1	μA
Input current during scan	I ₁₈	—	—	10	mA
Internal limiting at pin 10	V ₁₈₋₂₇	8,5	9	9,5	V
Switching threshold for 'black' current control ON	V ₁₈₋₂₇	7,6	8	8,4	V
Input resistance during scan	R ₁₈₋₂₇	1	1,5	2	kΩ
Input current during scan at pins 10, 20 and 21 (d.c.)	I _{10, 20, 21}	—	—	tbf	nA
Maximum charge/discharge current during measuring time		—	1	—	nA
NTSC					
Level at which the PAL/NTSC switch is activated (pins 24 and 25)	V ₂₄₋₂₅	—	8,8	9,2	V
Average output current (note 12)	I _{24 + 25(AV)}	75	90	105	μA
Hue control			see Fig. 5		

Notes to the characteristics

1. Signal with the negative-going sync; amplitude includes sync amplitude.
2. Indicated is a signal for a colour bar with 75% saturation; chrominance to burst ratio is 2,2 : 1.
3. Nominal contrast is specified as the maximum contrast -5 dB and nominal saturation as the maximum saturation -6 dB.
4. Cross coupling is measured under the following condition: input signal nominal, contrast and saturation such that nominal output signals are obtained. The signals at the output at which no signal should be available must be compared with the nominal output signal at that output.
5. The signal-to-noise ratio is defined as peak-to-peak signal with respect to r.m.s. noise.
6. All frequency variations are referred to 4,4 MHz carrier frequency.
7. These signal amplitudes are determined by the a.c.c. circuit of the reference part.
8. The demodulators are driven by a chrominance signal of equal amplitude for the (R-Y) and the (B-Y) components. The phase of the (R-Y) chrominance signal equals the phase of the (R-Y) reference signal. This also applies to the (B-Y) signals.
9. This value depends on the gain setting of the RGB output amplifiers and the drift of the picture tube guns. Higher black level values are possible (up to 5 V) but in that application the amplitude of the output signal is reduced.
10. The variation of the black-level during brightness control in the three different channels is directly dependent on the gain of each channel. Discolouration during adjustments of contrast and brightness does not occur because amplitude and the black-level change with brightness control are directly related.
11. This difference occurs when the source impedance of the data signals is 150Ω and the black level clamp pulse width is $4 \mu\text{s}$ (sandcastle pulse). For a lower impedance the difference will be lower.
12. The voltage at pins 24 and 25 can be changed by connecting the load resistors ($10 \text{ k}\Omega$ in this application) to the slider bar of the hue control potentiometer (see Fig. 8). When the transistor is switched on, the voltage at pins 24 and 25 is reduced below 9 V, and the circuit is switched to NTSC mode. The width of the burst gate is assumed to be $4 \mu\text{s}$ typical.

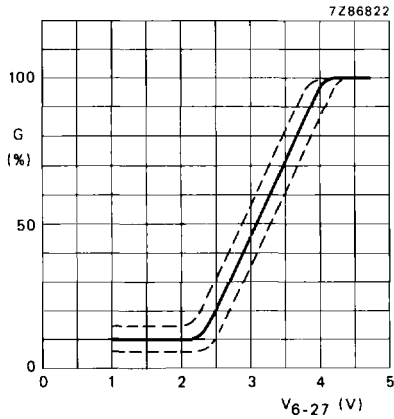

Fig. 2 Contrast control voltage range.

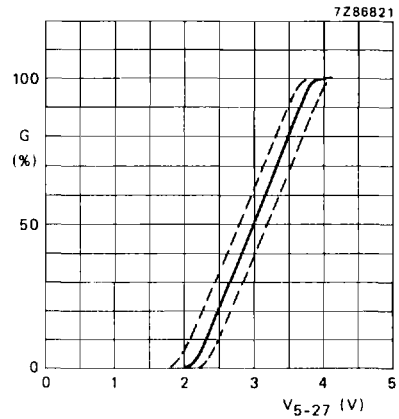

Fig. 3 Saturation control voltage range.

DEVELOPMENT DATA

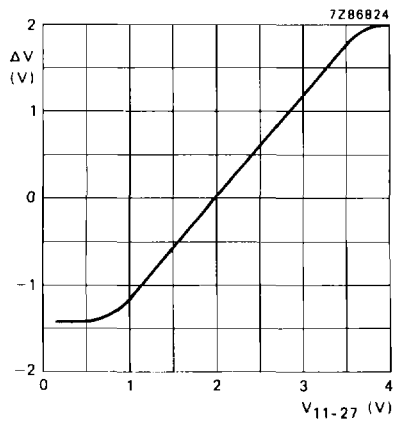

Fig. 4 Difference between black level and measuring level at the RGB outputs (ΔV) as a function of the brightness control input voltage (V_{11-27}).

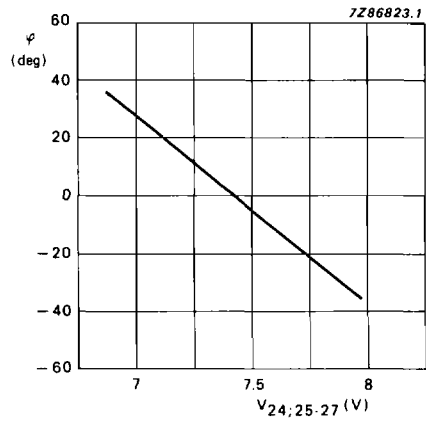

Fig. 5 Hue control voltage range.

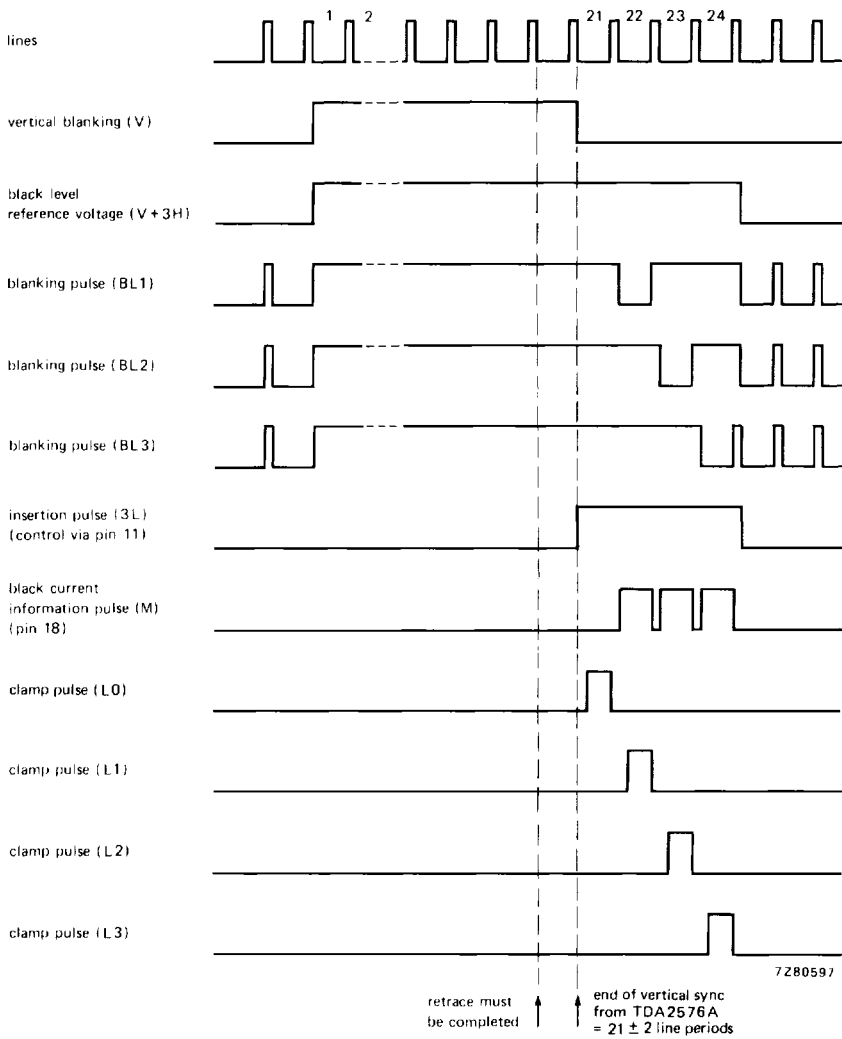

Fig. 6 Timing diagram for black-current stabilizing.

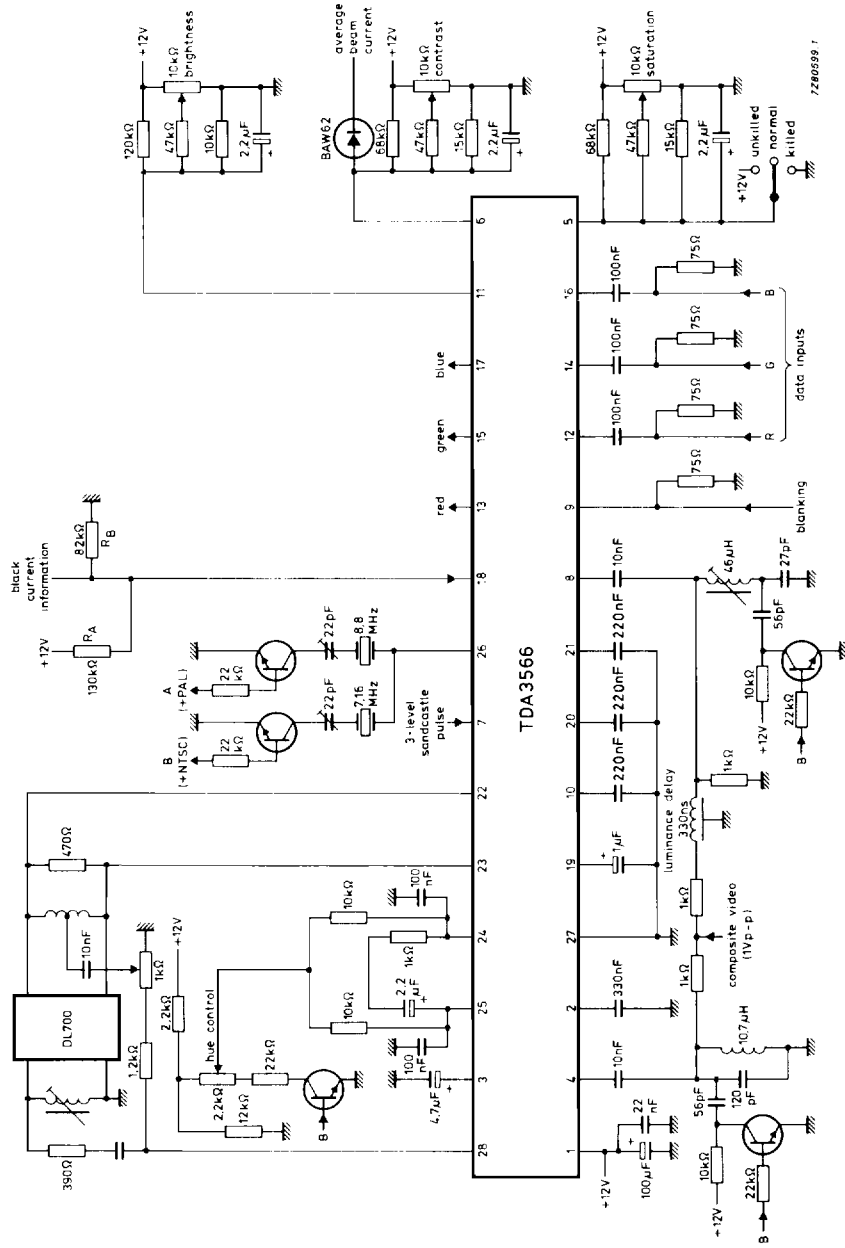

Fig. 8 Application diagram showing the TDA3566 for a PAL/NTSC decoder.

DEVELOPMENT DATA

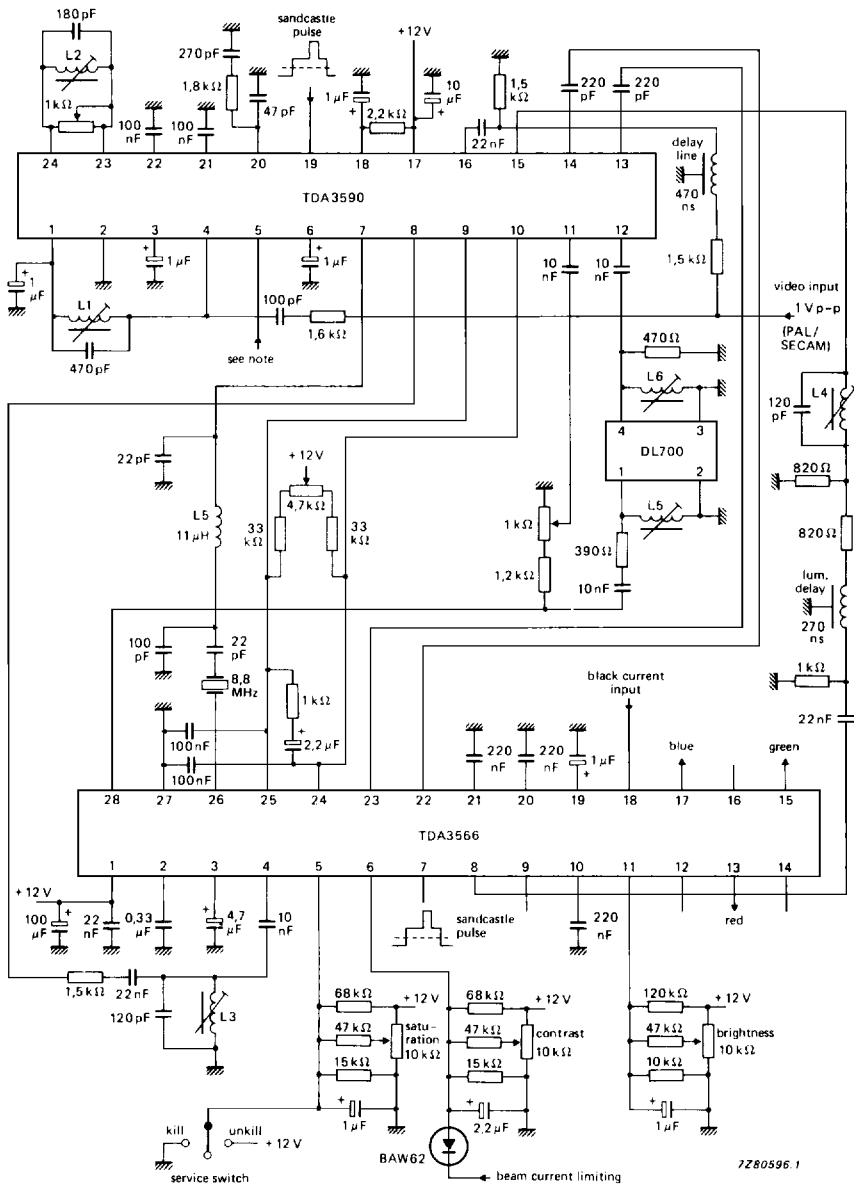

Fig. 9 PAL/SECAM application circuit diagram using the TDA3590 and TDA3566.

Note to pin 5 TDA3590:

- V_{5.2} < 1 V; horizontal identification and black level clamping.
- V_{5.2} > 11 V; vertical identification and artificial black level.
- V_{5.2} = 5 to 7 V; horizontal identification and artificial black level.