

**3V AM/FM ONE-CHIP RADIO**

**ADVANCE DATA**

- BUILT-IN FM F/E, AM/FM IF AND FM MPX
- AM DETECTOR COIL AND IF COUPLING CAPACITOR ARE NOT NEEDED
- COMPACT PACKAGE : 24-Pin Shrink
- OPERATING SUPPLY VOLTAGE RANGE  
 $V_{CC (opr)} = 1.8 \text{ to } 7.0V (T_A = 25^\circ C)$
- LED DRIVE CIRCUIT FOR TUNING INDICATION

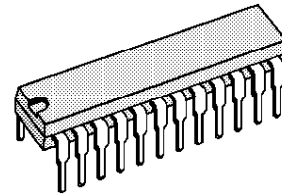

**SHRINK DIP24**  
(Plastic Package)

**ORDER CODE : TDA7222A**

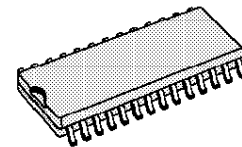

**SO28**  
(Plastic Micropackage)

**ORDER CODE : TDA7222AD**

**DESCRIPTION**

TDA7222A and TDA7222AD are AM/FM chip tuner ICs, which are designed for portable radios and 3V headphone radios.

**PIN CONNECTIONS**

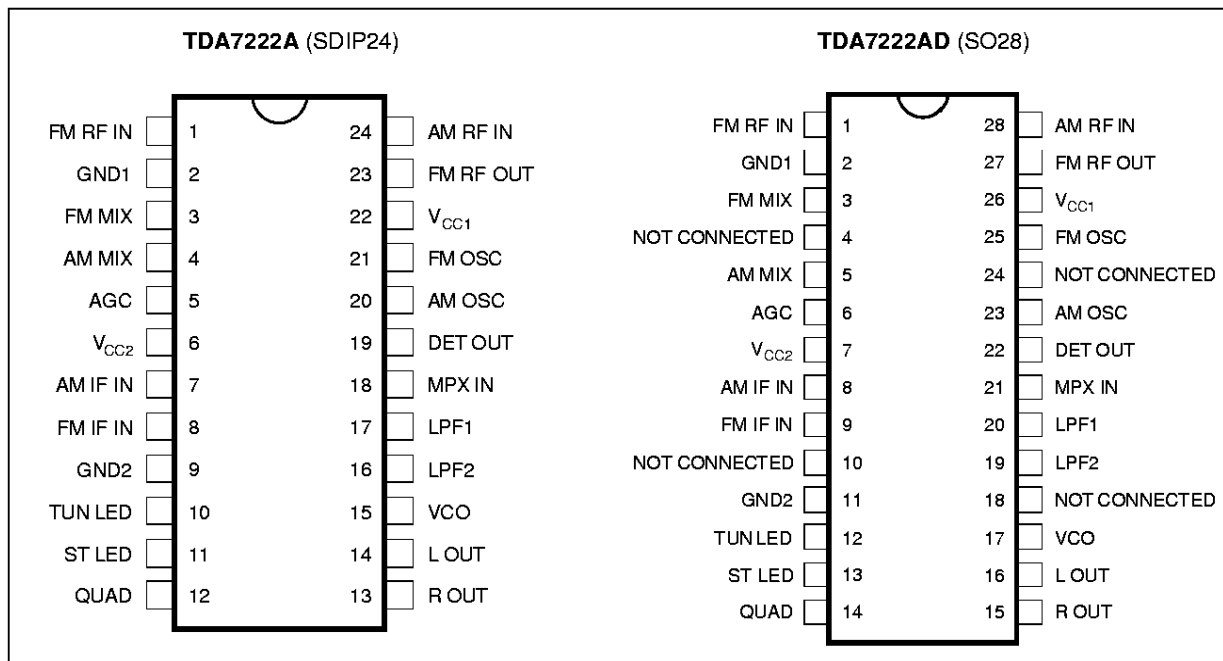

7222A-01.EPS / 7222AD-01.EPS

BLOCK DIAGRAM

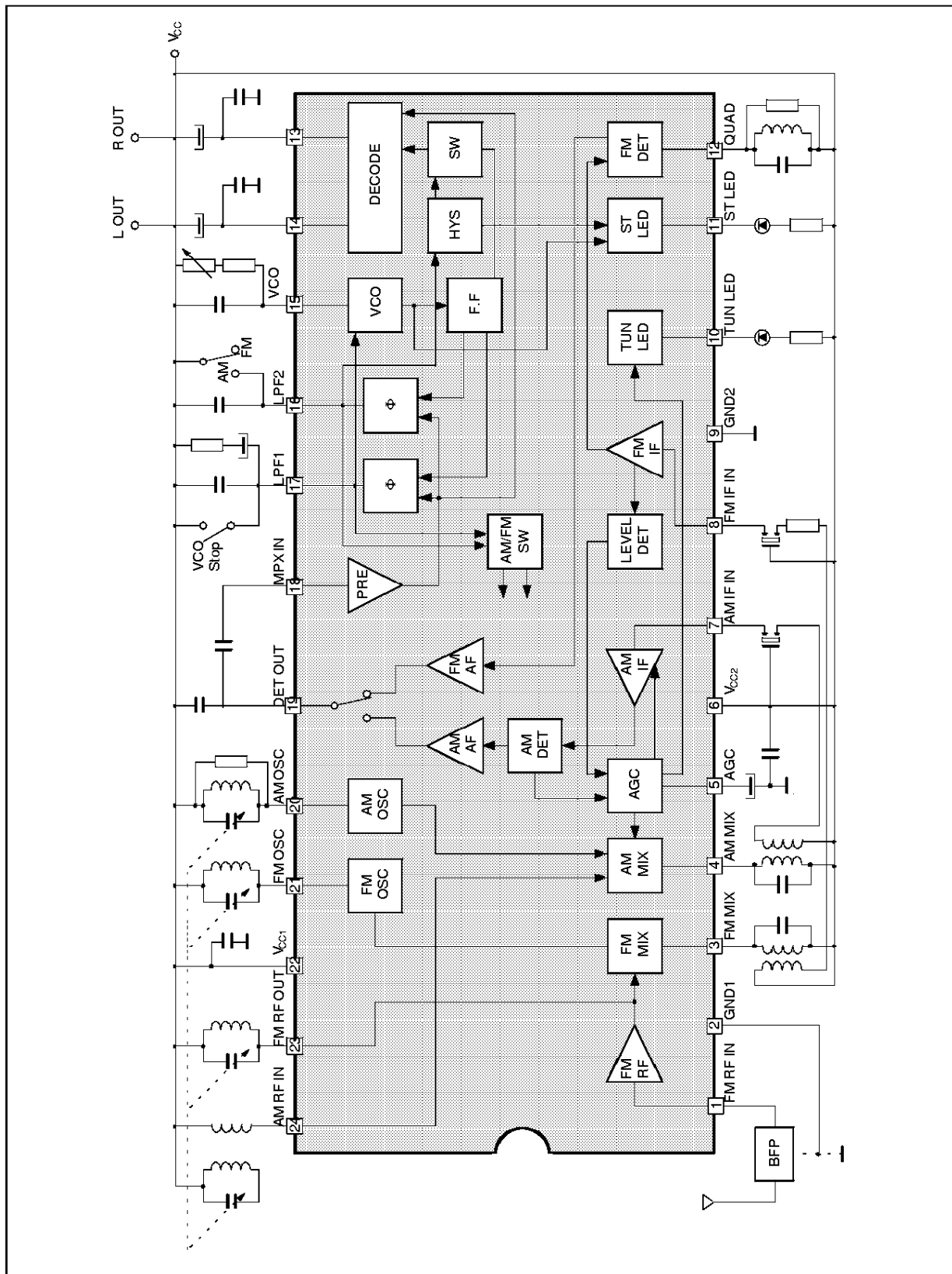

7222A-02 EPS

**ABSOLUTE MAXIMUM RATINGS**

Symbol	Parameter	Value	Unit
V <sub>S</sub>	Supply Voltage	9	V
I <sub>LED</sub>	LED Current	10	mA
V <sub>LED</sub>	LED Voltage	10	V
T <sub>oper</sub>	Operating Temperature	-20, +70	°C
T <sub>sig</sub>	Storage Temperature	-55, +150	°C

7222A-01.TBL

**RECOMMENDED OPERATING CONDITIONS**

Symbol	Parameter	Value	Unit
V <sub>S</sub>	Supply Voltage	1.8 to 7	V
T <sub>oper</sub>	Operating Temperature	0, +70	°C

7222A-02.TBL

**ELECTRICAL CHARACTERISTICS** (unless otherwise specified)

T<sub>A</sub> = 25°C, V<sub>CC</sub> = 3V F/E : f = 83MHz, f<sub>m</sub> = 1kHz  
 FM IF : f = 10.7MHz, Δf = ± 22.5kHz, f<sub>m</sub> = 1kHz  
 AM : f = 1MHz, MOD = 30%, f<sub>m</sub> = 1kHz  
 MPX : f<sub>m</sub> = 1kHz

Symbol	Parameter		Test Conditions	Min.	Typ.	Max.	Unit
I <sub>CC</sub> (FM)	Supply Current		V <sub>IN</sub> = 0, FM mode		13.2	20	mA
I <sub>CC</sub> (AM)			V <sub>IN</sub> = 0, AM mode		8.4	13.5	mA
V <sub>IN</sub> (lim)	F/E	Input Limiting Voltage	- 3dB limiting		10.0		dBμ
V <sub>OSC</sub>		Local OSC Voltage	f <sub>OSC</sub> = 72.3MHz		105		mV <sub>RMS</sub>
V <sub>IN</sub> (lim) IF	FM IF	Input Limiting Voltage	- 3dB limiting	40	46	53	dBμ
V <sub>OD</sub>		Recovered Output Voltage	V <sub>IN</sub> = 80dBμ	55	80	110	mV <sub>RMS</sub>
S/N		Signal to Noise Ratio	V <sub>IN</sub> = 80dBμ		70		dB
THD		Total Harmonic Distortion	V <sub>IN</sub> = 80dBμ		0.4		%
AMR		AM Rejection Ratio	V <sub>IN</sub> = 80dBμ		32		dB
V <sub>L</sub>		Lamp ON Sensitivity	I <sub>L</sub> = 1 mA	45	51	56	dBμ
G <sub>V</sub>	AM	Gain	V <sub>IN</sub> = 26dBμ	40	70	110	mV <sub>RMS</sub>
V <sub>OD</sub>		Recovered Output Voltage	V <sub>IN</sub> = 60dBμ	55	80	110	mV <sub>RMS</sub>
S/N		Signal to Noise Ratio	V <sub>IN</sub> = 60dBμ		42		dB
THD		Total Harmonic Distortion	V <sub>IN</sub> = 60dBμ		1.0		%
V <sub>L</sub>		Lamp ON Sensitivity	I <sub>L</sub> = 1 mA	20	25	30	dBμ
R19	Pin 19 Output Resistance		FM mode AM mode		0.75 12.75		kΩ kΩ
R <sub>IN</sub>	MPX	Input Resistance			24		kΩ
R <sub>OUT</sub>		Output Resistance			5		kΩ
V <sub>IN</sub> (Max.) Stereo		Max. Composite Signal Input Voltage	L + R = 90%, P = 10% f <sub>m</sub> = 1kHz, THD = 3%		350		mV <sub>RMS</sub>
Sep		Separation	f <sub>m</sub> = 100Hz f <sub>m</sub> = 1kHz f <sub>m</sub> = 10kHz L + R = 135mV <sub>RMS</sub> P = 15mV <sub>RMS</sub>	25	32 32 32		dB dB dB
THD Monaural		Total Harmonic Distortion (monaural)	V <sub>IN</sub> = 150mV <sub>RMS</sub>		0.2		%
THD Stereo		Total Harmonic Distortion (stereo)	L + R = 135mV <sub>RMS</sub> P = 15mV <sub>RMS</sub>		0.2		%
G <sub>V</sub> (MPX)		Voltage Gain	V <sub>IN</sub> = 150mV <sub>RMS</sub>	-5	-3	-1	dB
C.B.		Channel Balance	V <sub>IN</sub> = 150mV <sub>RMS</sub>	-2	0	2	dB

7222A-03.TBL

# TDA7222A - TDA7222AD

## ELECTRICAL CHARACTERISTICS (unless otherwise specified) (continued)

$T_A = 25^\circ\text{C}$ ,  $V_{CC} = 3\text{V}$     F/E    :  $f = 83\text{MHz}$ ,  $f_m = 1\text{kHz}$   
                                          FM IF    :  $f = 10.7\text{MHz}$ ,  $\Delta f = \pm 22.5\text{kHz}$ ,  $f_m = 1\text{kHz}$   
                                          AM      :  $f = 1\text{MHz}$ ,  $\text{MOD} = 30\%$ ,  $f_m = 1\text{kHz}$   
                                          MPX    :  $f_m = 1\text{kHz}$

Symbol	Parameter	Test Conditions	Min.	Typ.	Max.	Unit
$V_L$ (ON)	Stereo Lamp (ON) Sensitivity	Pilot Input	2	6		mV <sub>RMS</sub>
$V_L$ (OFF)			Stereo Lamp (OFF) Sensitivity		2	
$V_H$	Stereo Lamp Hysteresis			3		mV <sub>RMS</sub>
C.R.	Capture Range	$P = 15\text{mV}_{RMS}$		$\pm 3$		%
S/N	Signal to Noise Ratio			70		dB

7222A-04.TBL

## COIL DATA

Coil N°		f (Hz)	L (μH)	C <sub>0</sub> (pF)	Q <sub>0</sub>	Turns					Wire	Ref. *
						1-2	2-3	1-3	1-4	4-6		
L <sub>1</sub>	FM RF	100M			100				2 $\frac{1}{2}$		0.5∅ UEW	S -53T-037-202
L <sub>2</sub>	FM OSC	100M			100			2 $\frac{3}{4}$			0.5∅ UEW	S -0258-24
L <sub>3</sub>	AM OSC	796k	238		115	13	73				0.08∅ UEW	S -4147-1356-038
T <sub>1</sub>	FM MIX	10.7M		75	100			13		2	0.1∅ UEW	S -2153-414-041
T <sub>2</sub>	AM MIX	455k		180	120			180		15	0.08∅ UEW	S -2150-2162-165
T <sub>3</sub>	FM DET	10.7M		47	165			16			0.09∅ MUEW	S -2153-4095-122

7222A-05.TBL

\* S : Sumida Electric CO, LTD.

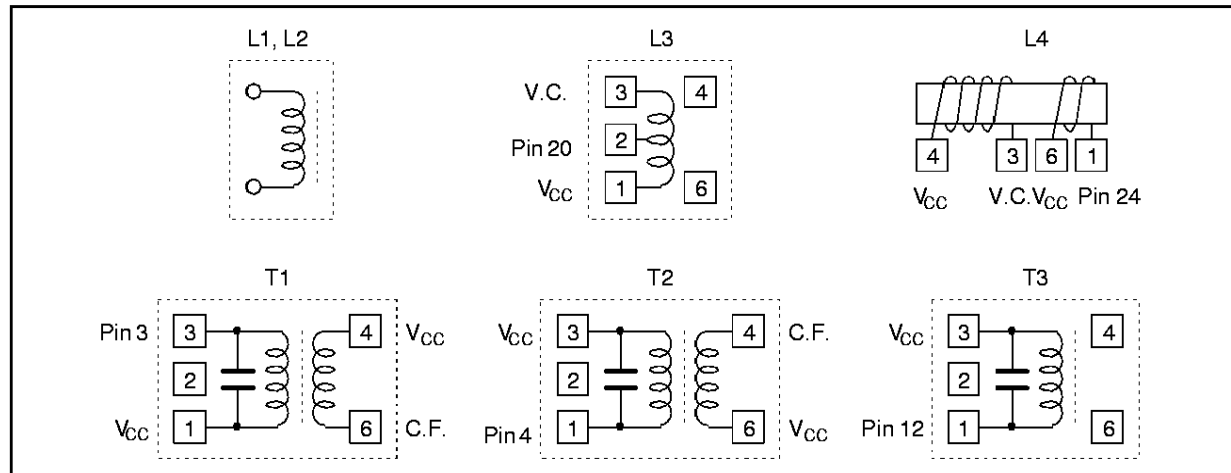

7222A-03.EPS

APPLICATION CIRCUIT

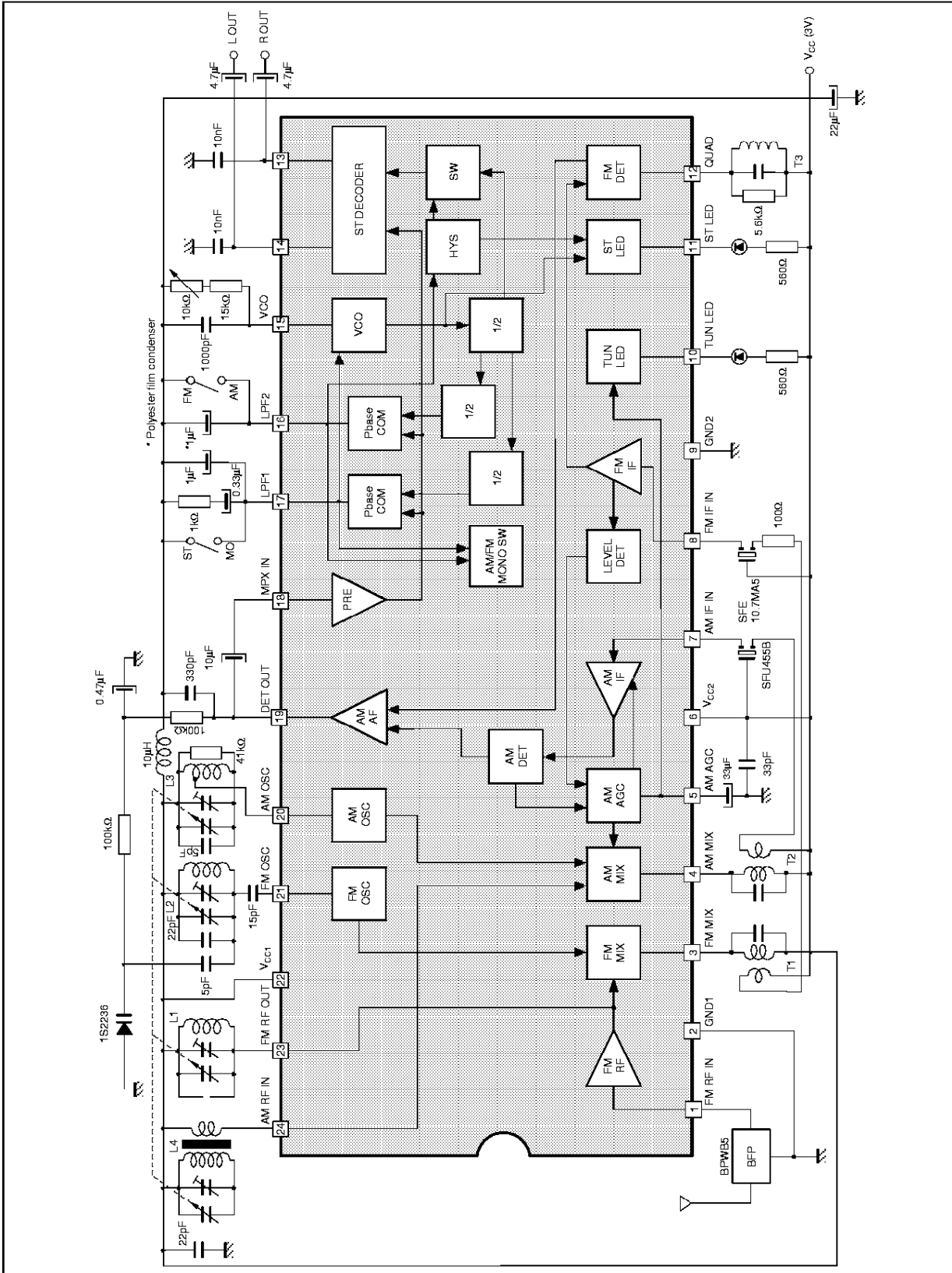

7222A-04 EPS

# TDA7222A - TDA7222AD

## PACKAGE MECHANICAL DATA (TDA7222A) 24 PINS - PLASTIC SHRINK DIP

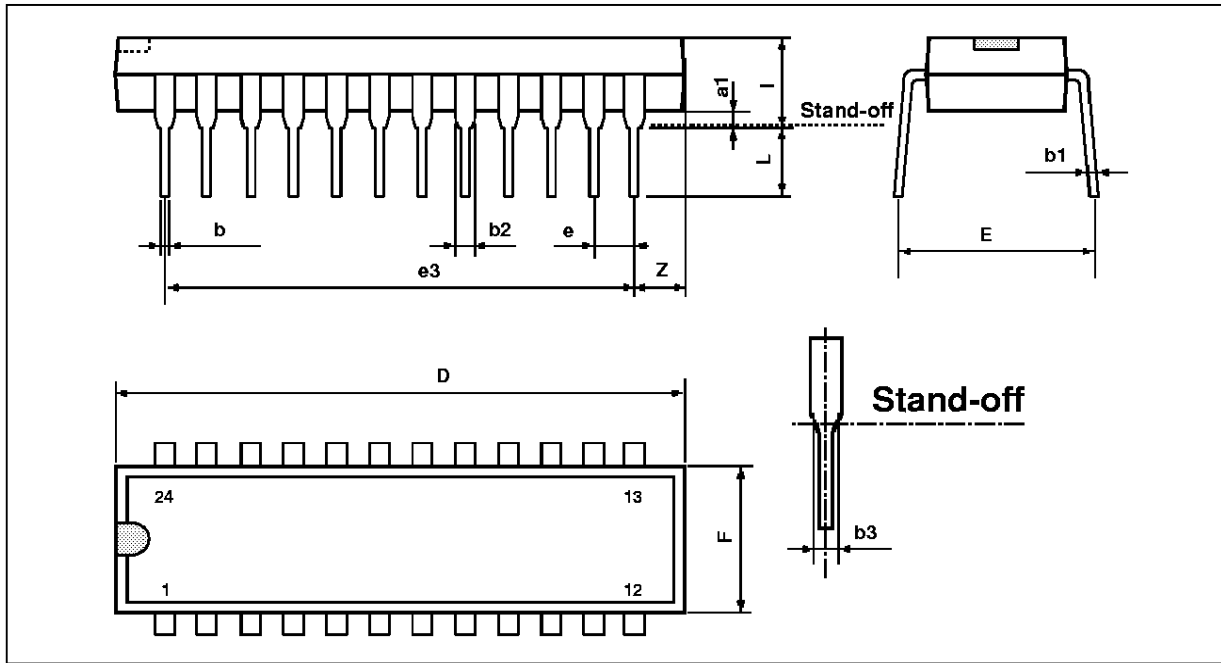

PMSDIP24.EPS

Dimensions	Millimeters			Inches		
	Min.	Typ.	Max.	Min.	Typ.	Max.
A		3.3			0.130	
a1	0.51			0.020		
b	0.35		0.59	0.014		0.023
b1	0.2		0.36	0.008		0.014
b2	0.75		1.42	0.030		0.056
b3	0.75			0.030		
D			23.11			0.910
E	7.95		9.73	0.313		0.383
e		1.778			0.070	
e3		19.558			0.770	
e4		7.62			0.300	
F			6.86			0.270
i			5.08			0.200
L	2.54			0.100		

SDIP24.TBL

**PACKAGE MECHANICAL DATA (TDA7222AD)**  
 28 PINS - PLASTIC MICROPACKAGE (SO)

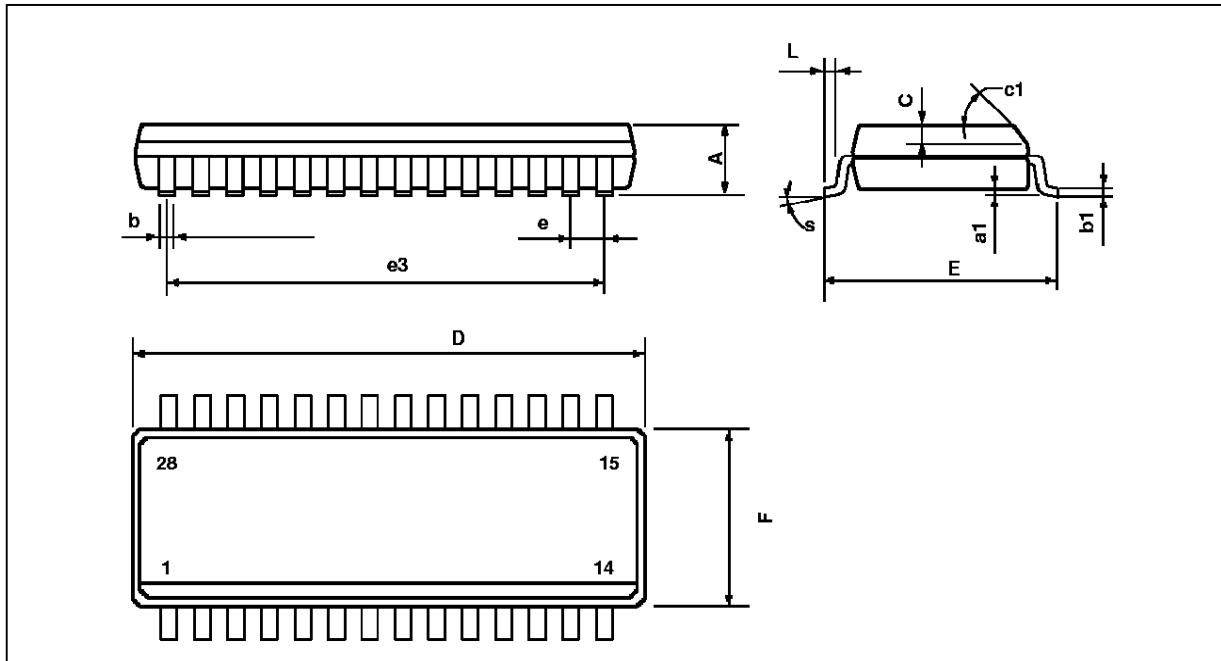

PM-SC28E/PS

Dimensions	Millimeters			Inches		
	Min.	Typ.	Max.	Min.	Typ.	Max.
A			2.65			0.104
a1	0.1		0.3	0.004		0.012
b	0.35		0.49	0.014		0.019
b1	0.23		0.32	0.009		0.013
C		0.5			0.020	
c1	45° (typ.)					
D	17.7		18.1	0.697		0.713
E	10		10.65	0.394		0.419
e		1.27			0.050	
e3		16.51			0.65	
F	7.4		7.6	0.291		0.299
L	0.4		1.27	0.016		0.050
S	8° (max.)					

SC28E/TBL

Information furnished is believed to be accurate and reliable. However, SGS-THOMSON Microelectronics assumes no responsibility for the consequences of use of such information nor for any infringement of patents or other rights of third parties which may result from its use. No licence is granted by implication or otherwise under any patent or patent rights of SGS-THOMSON Microelectronics. Specifications mentioned in this publication are subject to change without notice. This publication supersedes and replaces all information previously supplied. SGS-THOMSON Microelectronics products are not authorized for use as critical components in life support devices or systems without express written approval of SGS-THOMSON Microelectronics.

© 1995 SGS-THOMSON Microelectronics - All Rights Reserved

Purchase of I<sup>2</sup>C Components of SGS-THOMSON Microelectronics, conveys a license under the Philips I<sup>2</sup>C Patent. Rights to use these components in a I<sup>2</sup>C system, is granted provided that the system conforms to the I<sup>2</sup>C Standard Specifications as defined by Philips.

SGS-THOMSON Microelectronics GROUP OF COMPANIES

Australia - Brazil - China - France - Germany - Hong Kong - Italy - Japan - Korea - Malaysia - Malta - Morocco  
 The Netherlands - Singapore - Spain - Sweden - Switzerland - Taiwan - Thailand - United Kingdom - U.S.A.