

HORIZONTAL AND VERTICAL DEFLECTION CIRCUIT

- DIRECT FRAME-YOKE DRIVE ($\pm 1A$)
- COMPOSITE VIDEO SIGNAL INPUT CAPABILITY
- FRAME OUTPUT PROTECTION AGAINST SHORT CIRCUITS
- PLL
- SUPER SANDCASTLE OUTPUT
- VERY FEW EXTERNAL COMPONENTS
- VERY LOW COST POWER PACKAGE
- STABLE FRAME BLANKING PULSE, GENERATED BY EXTERNAL RC, FOR COMPATIBILITY WITH TEA 5640

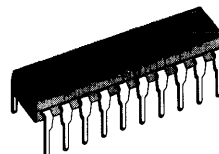

POWERDIP 16 + 2 + 2
(Plastic Package)

ORDER CODE : TDA8218

DESCRIPTION

The TDA8218 is an horizontal and vertical deflection circuit with super sandcastle generator. Used with automatic PAL/SECAM decoder TEA5640, this IC permits a complete low-cost solution for PAL/SECAM applications.

PIN CONNECTIONS

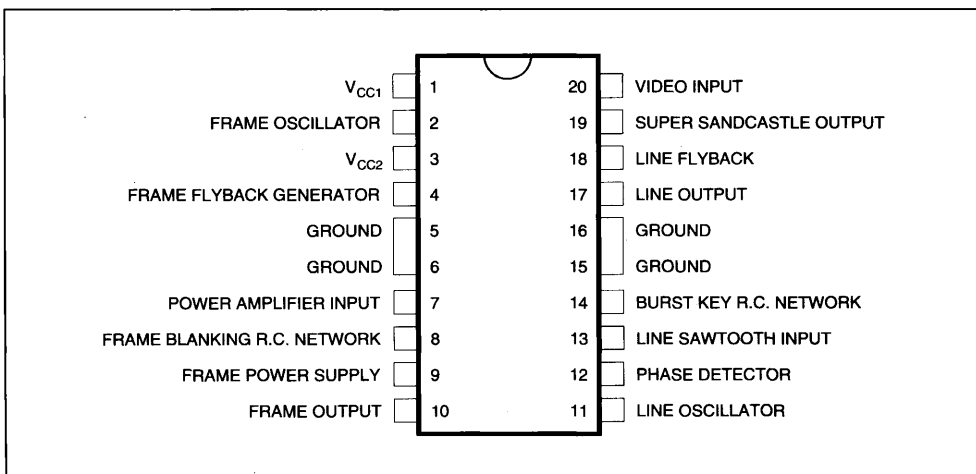

8218-01 EPS

BLOCK DIAGRAM

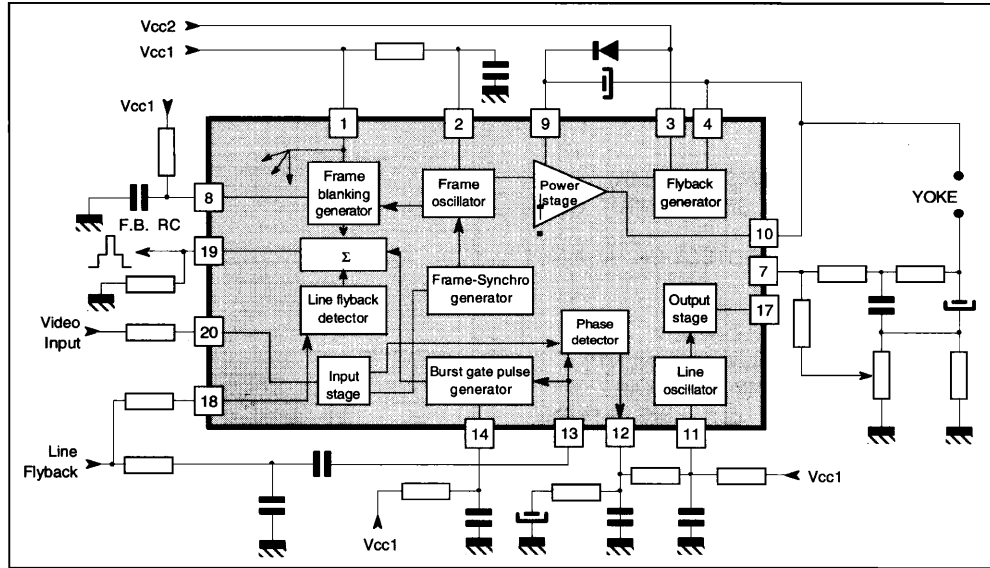

8218-02 EPS

ABSOLUTE MAXIMUM RATINGS

Symbol	Parameter	Value	Unit
V _{CC1}	Supply Voltage	30	V
V _{CC2}	Flyback Generator Supply Voltage	35	V
V ₉	Frame Power Supply Voltage	60	V
I _{10NR}	Frame Output Current (non repetitive)	± 1.5	A
I ₁₀	Frame Output Current (continuous)	± 1	A
V ₁₇	Line Output Voltage (external)	60	V
I _{P17}	Line Output Peak Current	0.8	A
I _{C17}	Line Output Continuous Current	0.4	A
T _{STG}	Storage Temperature	-40 to + 150	°C
T _J	Max Operating Junction Temperature	+ 150	°C
T _{AMB}	Operating Ambient Temperature	0 to 70	°C

8218-01 TEL

THERMAL DATA

Symbol	Parameter	Value	Unit
R _{TH(j-c)}	Max Junction-case Thermal Resistance	10	°C/W
R _{TH(j-a)}	Typical Junction-ambient Thermal Resistance (Soldered on a 35µm thick 45cm ² PC Board copper area)	40	°C/W
T _J	Max Recommended Junction Temperature	120	°C

8218-02 TR

ELECTRICAL CHARACTERISTICSV_{CC1} = 10 V, T_{AMB} = 25 °C (unless otherwise specified)

Symbol	Parameter	Min.	Typ.	Max.	Unit
--------	-----------	------	------	------	------

SUPPLY (Pin 1)

I _{CC1}	Supply Current		15	22	mA
V _{CC1}	Supply Voltage	9	10	10.5	V

VIDEO INPUT (Pin 20)

V20	Reference Voltage (I ₂₀ = -1μA)	1.4	1.75	2	V
MWF	Minimum Width of Frame Pulse (when synchronized with TTL signal)	50			μs

LINE OSCILLATOR (Pin 11)

LT11	Low Threshold Voltage	2.8	3.2	3.6	V
HT11	High Threshold Voltage	5.4	6.6	7.8	V
BI11	Bias Current		100		nA
DR11	Discharge Impedance	1.0	1.4	1.8	kΩ
FLP1	Free Running Line Period (R = 34.9kΩ Tied to V _{CC1} , C = 2.2nF Tied to Ground)	62	64	66	μs
OT11	Oscillator Threshold for Line Output Pulse Triggering		4.6		V
$\frac{\Delta F}{\Delta \theta}$	Horizontal Frequency Drift with Temperature (see application)		2		Hz/°C

LINE OUTPUT (Pin 17)

LV17	Saturation Voltage (I ₁₇ = 200mA)		1.1	1.6	V
OPW	Output Pulse width (line period = 64μs)	26	28	30	μs

LINE SAWTOOTH INPUT (Pin 13)

V13	Bias Voltage	1.8	2.4	3.2	V
Z13	Input Impedance	4.5	5.8	8	kΩ

PHASE DETECTOR (Pin 12)

I12	Output Current During Synchro Pulse	250	350	500	μA
RI12	Current Ratio (positive/negative)	0.95	1	1.05	
LI12	Leakage Current	-2		+2	μA
CV12	Control Range Voltage	2.60		7.10	V

FRAME BLANKING GENERATOR (Pin 8)

External R.C. Network (Typical values : R = 100kΩ, C = 22nF)					
T _{fb}	Blanking Time (Pin 19, T _{fb} = K8 .R.C.)		1.35		ms
K8	Time Blanking Coefficient	0.588	0.613	0.644	
I _{o8}	Output Current during the Frame Blanking : V ₈ = 2V		- 0.2	1	μA
I _{i8}	Input Current after the Frame Blanking : V ₈ = 7V	300	450	600	μA

FRAME OSCILLATOR (Pin 2)

LT2	Low Threshold Voltage	1.6	2.0	2.3	V
HT2	High Threshold Voltage	2.6	3.1	3.6	V
DIF2	LT2 - HT2		1.0		V
BI2	Bias Current		30		nA
DR2	Discharge Impedance	300	470	700	Ω
FFP1	Free Running Frame Period (R = 866kΩ Tied to V _{CC1} , C = 220nF Tied to Ground)	20.5	23	25	ms
MFP	Minimum Frame Period (I ₂₀ = -100μA) with the Same RC		12.8		ms
FPR	Frame Period Ratio = FFP/MFP	1.7	1.8	1.9	

8218-03 TEL

ELECTRICAL CHARACTERISTICSV_{CC1} = 10 V, T_{AMB} = 25 °C (unless otherwise specified)

Symbol	Parameter	Min.	Typ.	Max.	Unit
--------	-----------	------	------	------	------

FRAME OSCILLATOR (Pin 2) (continued)

FG	Frame Saw-tooth Gain Between Pin 1 and non Inverting Input of the Frame Amplifier		-0.4		
$\frac{\Delta F}{\Delta \theta}$	Vertical Frequency Drift with Temperature (see application)		4.10 ⁻³		Hz/°C

FRAME POWER SUPPLY (Pin 9)

V9	Operating Voltage (with flyback Generator)	10		58	V
I9	Supply Current (V9 = 30V)		9	15	mA

FLYBACK GENERATOR SUPPLY (Pin 3)

V _{CC2}	Operating Voltage	10		30	V
------------------	-------------------	----	--	----	---

FRAME OUTPUT (Pin 10)

Saturation Voltage to Ground (V9 = 30V)					
LV10A	I10 = 0.1A		0.06	0.6	V
LV10B	I10 = 1A		0.37	1	V
Saturation Voltage to V9 (V9 = 30V)					
HV10A	I10 = -0.1A		1.3	1.6	V
HV10B	I10 = -1A		1.7	2.4	V
Saturation Voltage to V9 in Flyback Mode (V10 > V9)					
FV10A	I10 = 0.1A		1.6	2.1	V
FV10B	I10 = 1A		2.5	4.5	V

FLYBACK GENERATOR (Pin 3 and Pin 4)

Flyback Transistor on (output = high state), V _{CC2} = 30V, V4/3 with					
F2DA F2DB	I _{4→3} = 0.1A I _{4→3} = 1A		1.5 3.0	2.1 4.5	V V
Flyback Transistor on (output = high state), V _{CC2} = 30V, V3/4 with					
FSVA FSVB	I _{3→4} = 0.1A I _{3→4} = 1A		0.8 2.2	1.1 4.5	V V
Flyback Transistor off (output = V9 - 8V), V9 - V _{CC2} = 30V					
FCI	Leakage Current Pin 3			170	μA

SUPER SANDCASTLE OUTPUT (Pin 19)

Output Voltages (R load = 2.2kΩ)					
SANDT2	Frame blanking pulse level	2	2.5	3	V
SANDL2	Line blanking pulse level	4	4.5	5	V
BG2	Burst key pulse level	8	9		V
Pulses width and timing					
SC3	Delay between middle of sync pulse and leading edge of burst key pulse	2.3	2.7	3.1	μs
SC2	Duration of burst key pulse Vertical blanking pulse width : Defined by external R.C. Pin 8	3.7	4	5	μs

LINE FLYBACK INPUT (Pin 18)

	Switching level		2		V
	Maximum input current at V _{PEAK} = 800V		8		mA
	Limiting voltage at maximum current		4.3		V
τ	RC network time constant (Note 1) for the burst key pulse		6		μS

Note : 1. An RC network is connected to this input. Typical value for the resistor is 27kΩ and 220pF for the capacitor. A different time constant for RC changes the delay between the middle of the line synchro pulse and the leading edge of the burst key pulse but also the duration of the burst key pulse.

GENERAL DESCRIPTION

The TDA8218 performs all the video and power functions required to provide signals for the line driver and frame yoke.

It contains:

- A synchronization separator
- An integrated frame separator without external components

- A saw-tooth generator for the frame
- A power amplifier for direct drive of frame yoke (short circuit protected)
- An open collector output for the line driver
- A line phase detector and a voltage control oscillator
- A super sandcastle generator.

Figure 1 : Synchronization Separator Circuit

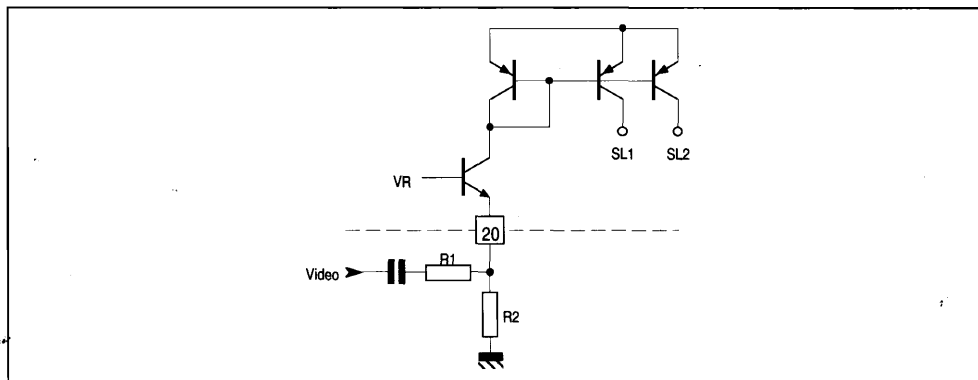

8218-03.EPS

The slice level of sync-separation is fixed by value of the external resistors R1 and R2. V_R is an internally fixed voltage.

Figure 2 : Frame Separator

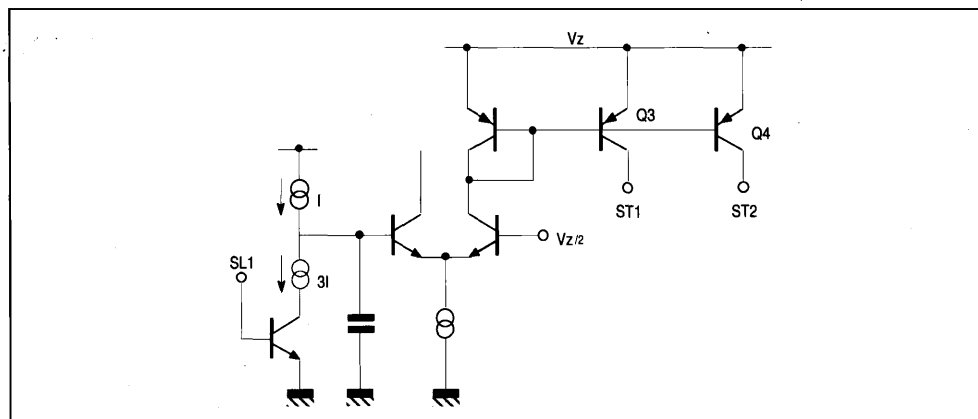

8218-04.EPS

The sync-pulse allows the discharge of the capacitor by a $2 \times I$ current. A line sync-pulse is not able to discharge the capacitor under $V_z/2$. A frame

sync-pulse permits the complete discharge of the capacitor, so during the frame sync-pulse Q3 and Q4 provide current for the other parts of the circuit.

Figure 3 : Line Oscillator

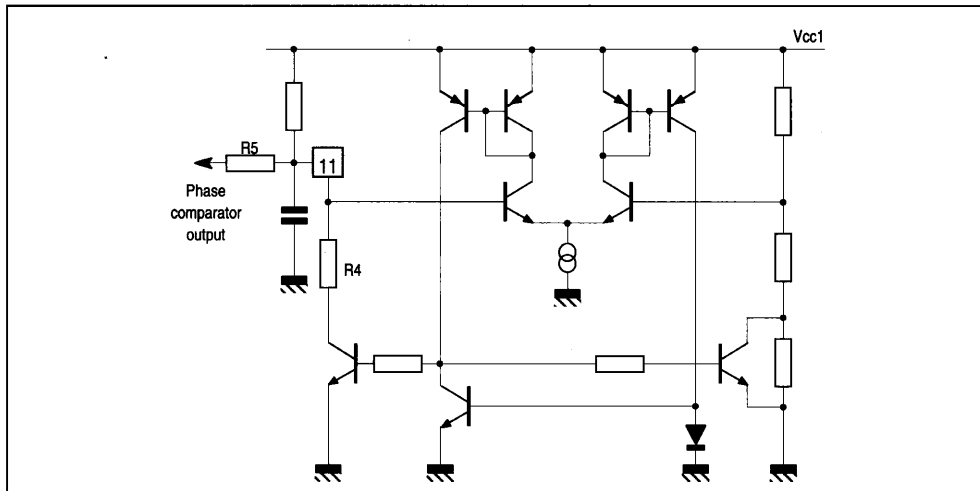

8218-06.EPS

The oscillator thresholds are internally fixed by resistors. The discharge of the capacitor depends on the internal resistor R4. The control voltage is applied on resistor R5.

The sync-pulse drives the current in the comparator. The line flyback integrated by the external network gives on pin 13 a saw tooth, the DC offset of this saw tooth is fixed by VC. The comparator

output provides a positive current for the part of the signal on pin 13 greater than to VC and a negative current for the other part. When the line flyback and the video signal are synchronized, the output of the comparator is an alternatively negative and positive current. The frame sync-pulse inhibits the comparator to prevent frequency drift of the line oscillator on the frame beginning.

Figure 4 : Phase Comparator

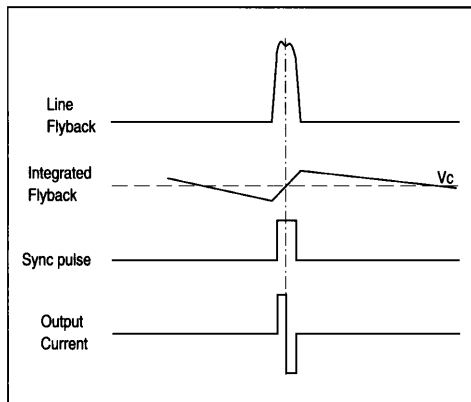

8218-06.EPS

Figure 5

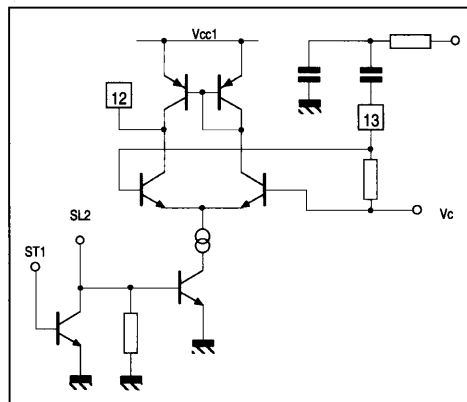

8218-07.EPS

Line output (Pin 17)

It is an open-collector output. The output positive pulse time is 28µs for a 64µs period. The oscillator thresholds are internally fixed by resistors. The oscillator is synchronized during the last half free run period. The input current during the charge of the capacitor is less than 100nA.

Frame output amplifier

This amplifier is able to drive directly the frame yoke. Its output is short circuit and overload protected; it contains also a thermal protection.

The line flyback detection is provided by a comparator which compares the input line flyback pulse to an internal reference. The burst gate pulse position is fixed by the external RC network (pin 14). It

is referenced to the middle of the line flyback.

The frame blanking generator is a monostable with external R.C. The start blanking pulse is triggered by the falling edge of the frame saw-tooth (Pin 2). The reset is provided by a comparator which compares the capacitor voltage during its charge to an internal threshold fixed by resistors.

The frame blanking time is defined by :

$$T_{fb} = 0.613 \cdot R \cdot C$$

This pulse is available on Super Sand Castle output (Pin 19).

Remark : For compatibility with TEA5640, frame blanking time must be larger than 1.15ms with centered value @ 1.35ms (R = 100kΩ ± 1%, C = 22nF ± 5%)

Figure 6 : Frame Oscillator

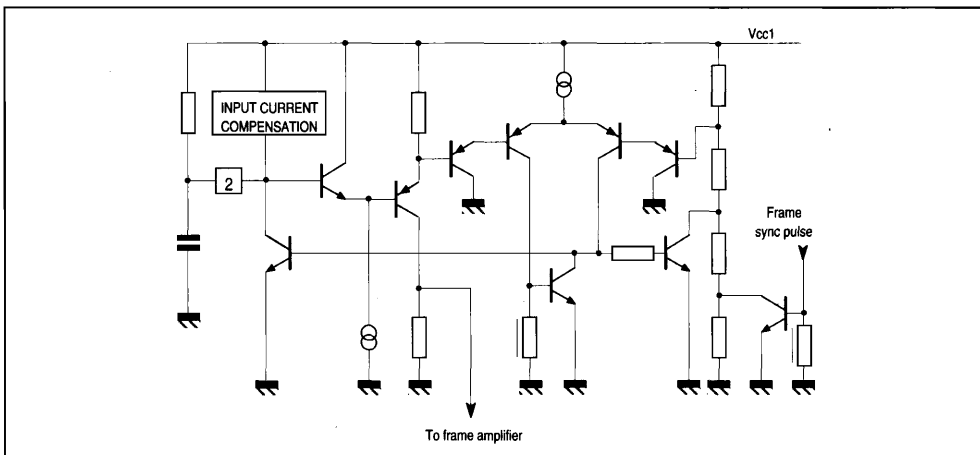
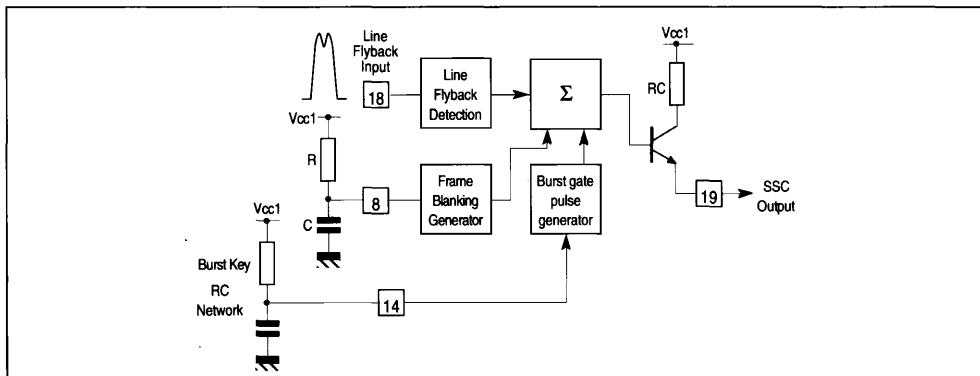
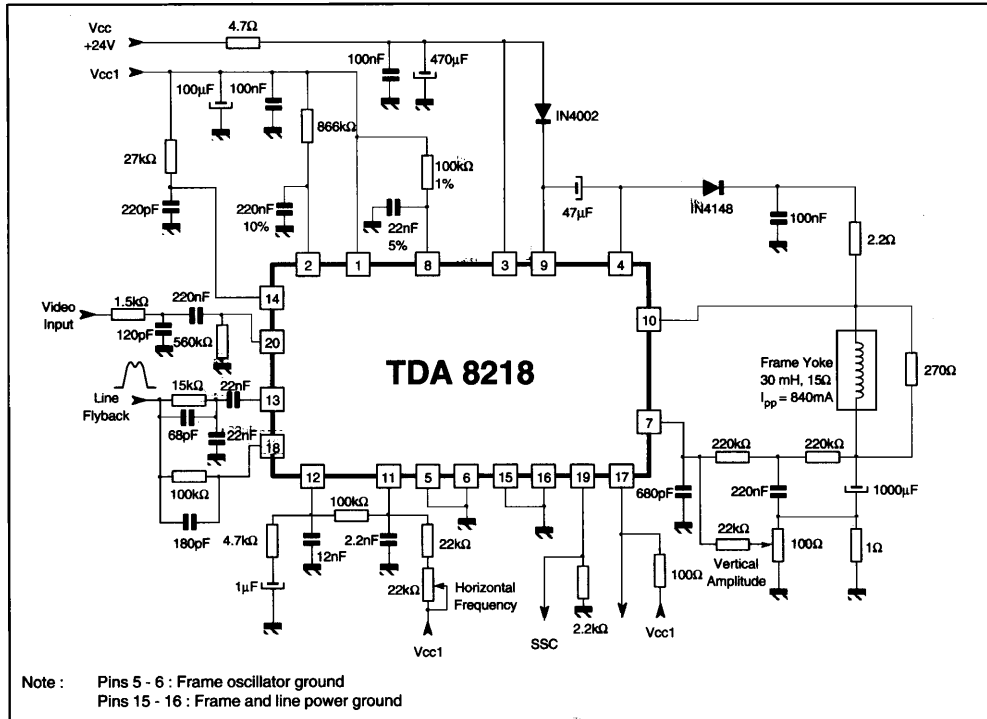

Figure 7 : Super sandcastle generator



TYPICAL APPLICATION



8218-10.EPS