

Smart Green-Mode PWM Controller with Multiple Protections

REV:02

General Description

The LD7522 is a low startup current, current mode PWM controller with green-mode power-saving operation. The SOP-8/DIP-8 package integrated functions such as the leading-edge blanking of the current sensing, internal slope compensation, line compensation, and several protection features. The protection functions include cycle-by-cycle current limit, OVP, OTP, OLP, and brownout protection. It provides the users a high efficiency, low external component counts solution for AC/DC power applications.

Furthermore, to satisfy various protection requirements, both latch-mode protection and auto-recoverable protection can be easily achieved by configuring LD7522 on different operation modes.

The special green-mode control is not only to achieve the low power consumption but also to offer a non-audible-noise operation when the LD7522 is operating under light load or no load condition.

Features

- High-Voltage CMOS Process with Excellent ESD protection
- Very Low Startup Current ($< 35\mu\text{A}$)
- Current Mode Control
- Non-audible-noise Green Mode Control
- UVLO (Under Voltage Lockout)
- LEB (Leading-Edge Blanking) on CS Pin
- Internal Slope Compensation
- Programmable Line Compensation
- OVP (Over Voltage Protection)
- OLP (Over Load Protection)
- OTP (Over Temperature Protection) through a NTC
- Brownout Protection
- Flexibility on Latch/Auto-Recoverable Protection Mode
- 500mA Driving Capability

Applications

- Switching AC/DC Adaptor and Battery Charger
- Open Frame Switching Power Supply
- LCD Monitor/TV Power

Typical Application

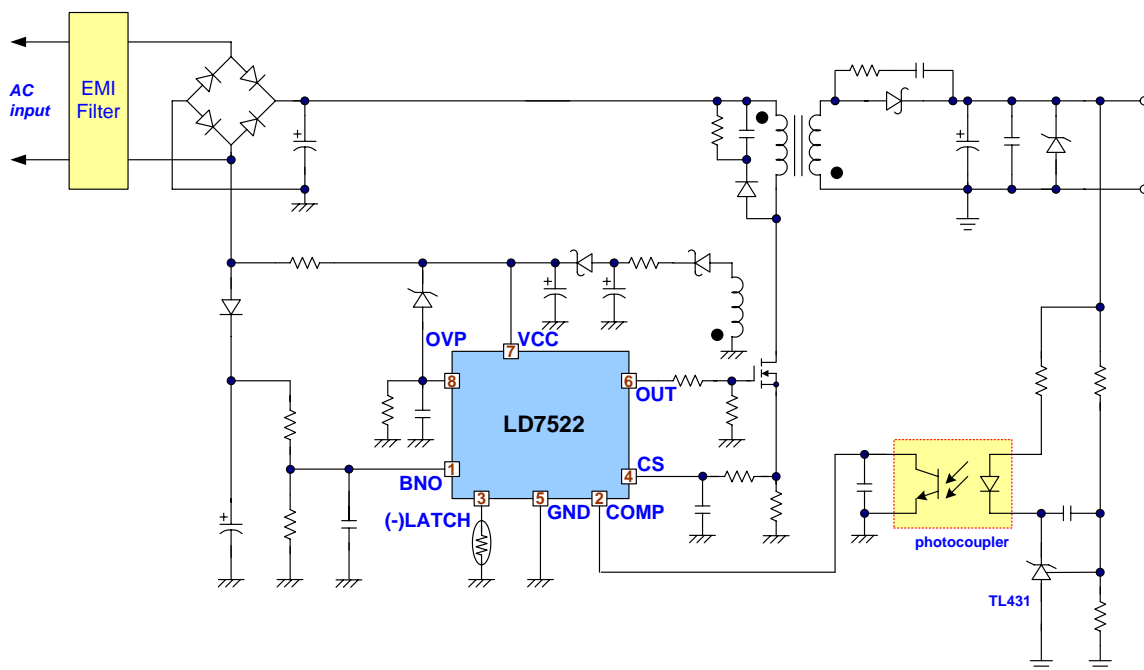

Pin Configuration

SOP-8 & DIP-8(TOP VIEW)

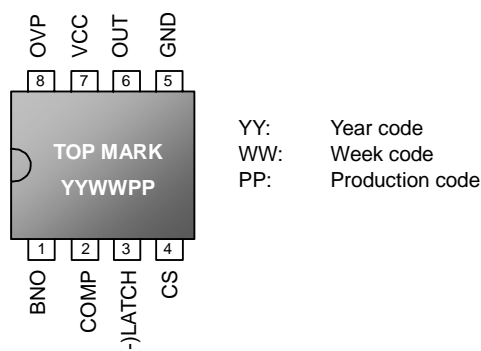

Ordering Information

Part number	Package	Top Mark	Shipping
LD7522 PS	SOP-8	LD7522PS	2500 /tape & reel
LD7522 PN	DIP-8	LD7522PN	3600 /tube /Carton

Note: The LD7522 is ROHS compliant.

Pin Descriptions

PIN	NAME	FUNCTION
1	BNO	Brownout Protection Pin. Connected a resistor divider from this pin to bulk capacitor voltage to set the brownout level and line compensation. When the voltage of this pin is lower than threshold voltage, the PWM output will be off.
2	COMP	Voltage feedback pin (same as the COMP pin in UC384X), By connecting a photo-coupler to close the control loop and achieve the regulation.
3	(-) LATCH	Pull this pin to lower than 2.5V will shutdown the controller to the latch mode until the AC power-on recycling. By connecting a NTC from this pin to ground will achieve the OTP protection function. Keep this pin as floating to disable the latch protection.
4	CS	Current sense pin, connect to sense the MOSFET current
5	GND	Ground
6	OUT	Gate drive output to drive the external MOSFET
7	VCC	Supply voltage pin
8	OVP	This pin is high-active to provide the OVP function. By the connecting a zener or a resistor voltage divider to Vcc will set the OVP level. Whenever the voltage is higher than 2.5V, the OVP is tripped and the gate drive will be off. Short this pin to ground to disable the OVP function.

Absolute Maximum Ratings

Supply Voltage VCC.....	30V
COMP, CS, (-) LATCH.....	-0.3 ~7V
OVP, BNO.....	-0.3 ~5V
Junction Temperature.....	150°C
Operating Ambient Temperature.....	-40°C to 85°C
Storage Temperature Range.....	-65°C to 150°C
Package Thermal Resistance (SOP-8).....	160°C/W
Package Thermal Resistance (DIP-8).....	100°C/W
Power Dissipation (SOP-8, at Ambient Temperature = 85°C).....	400mW
Power Dissipation (DIP-8, at Ambient Temperature = 85°C).....	650mW
Lead temperature (Soldering, 10sec).....	260°C
ESD Voltage Protection, Human Body Model	3KV
ESD Voltage Protection, Machine Model.....	200V
Gate Output Current.....	500mA

Caution:

Stresses beyond the ratings specified in “Absolute Maximum Ratings” may cause permanent damage to the device. This is a stress only rating and operation of the device at these or any other conditions above those indicated in the operational sections of this specification is not implied.

Electrical Characteristics

 (T_A = +25°C unless otherwise stated, V_{CC}=15.0V)

PARAMETER	CONDITIONS	MIN	TYP	MAX	UNITS
Supply Voltage (VCC Pin)					
Startup Current			20	35	μA
Operating Current (with 1nF load on OUT pin)	V _{COMP} =0V		3.5	5.0	mA
	V _{COMP} =3V		3.0		mA
	Protection Mode (note 1)		0.7		mA
UVLO (off)		9.0	10.0	11.0	V
UVLO (on)		15.0	16.0	17.0	V
Voltage Feedback (Comp Pin)					
Short Circuit Current	V _{COMP} =0V		2.5	4.0	mA
Green Mode Threshold VCOMP			2.35		V
Current Sensing (CS Pin)					
Maximum Input Voltage, V _{CS(OFF)}	V _{BNO} =0V (note 2)	0.800	0.850	0.900	V
	V _{BNO} =1.30V	0.748	0.798	0.848	V
	V _{BNO} =3.75V	0.650	0.700	0.750	V
Leading Edge Blanking Time			350		nS
Input impedance		1			MΩ
Delay to Output			150		nS
Gate Drive Output (OUT Pin)					
Output Low Level	V _{CC} =15V, I _o =20mA			1.0	V
Output High Level	V _{CC} =15V, I _o =20mA	9.0			V
Rising Time	Load Capacitance=1000pF		50	160	nS
Falling Time	Load Capacitance=1000pF		30	60	nS
Oscillator					
Frequency		60	65	70	KHz
Green Mode Frequency			20		KHz
Frequency Temp. Stability	(-40°C –85°C)			3	%
Frequency Voltage Stability	(V _{CC} =12V-30V)			1	%
Latch Protection ((-)LATCH Pin)					
(-)LATCH Pin Source Current		92	100	108	μA
Turn-On Trip Level		3.3	3.50	3.7	V
Turn-Off Trip Level		2.40	2.50	2.60	V
(-)LATCH pin de-bounce time		100			μS
De-latch Vcc Level	(PDR, Power Down Reset)	6.8	8.0	8.7	V

Note 1: When OVP, OLP, or Latch Protection is tripped.

 Note 2: Guaranteed by design because V_{cs(off)} can't be measured when V_{BNO}=0V.

Typical Performance Characteristics

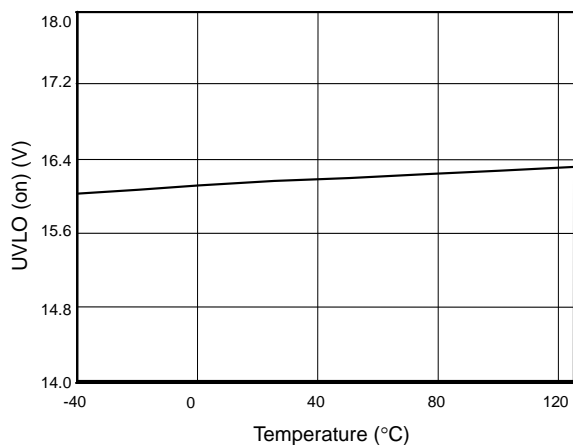

Fig. 1 UVLO (on) vs. Temperature

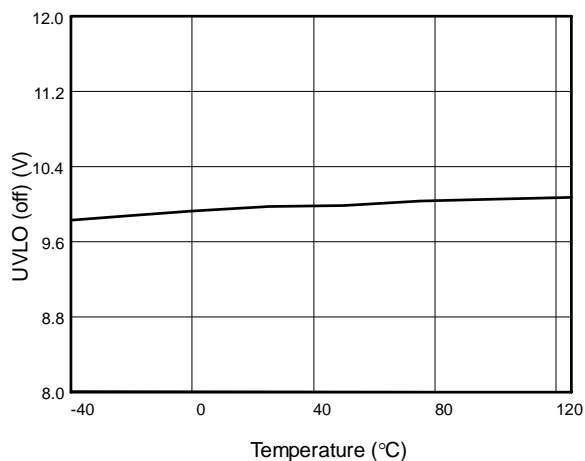

Fig. 2 UVLO (off) vs. Temperature

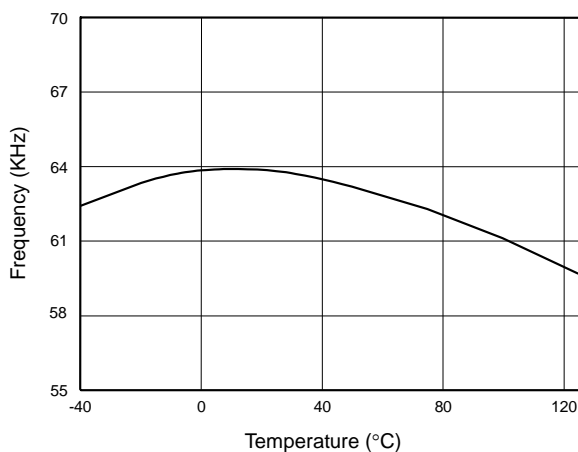

Fig. 3 Frequency vs. Temperature

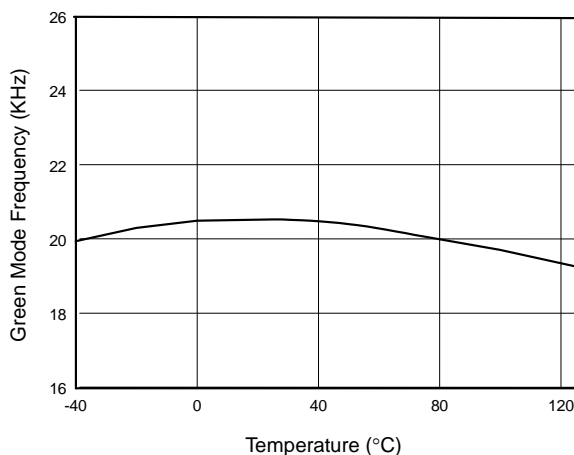

Fig. 4 Green Mode Frequency vs. Temperature

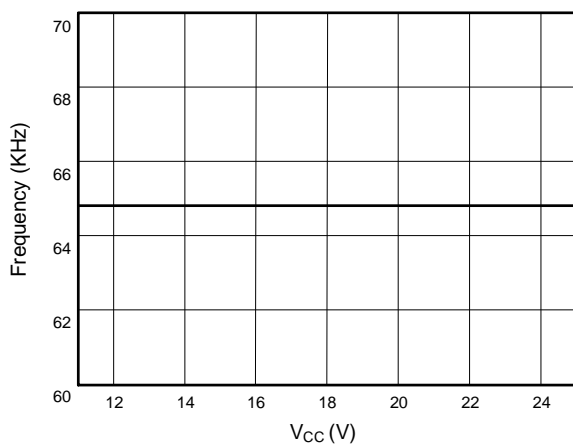

Fig. 5 Frequency vs. VCC

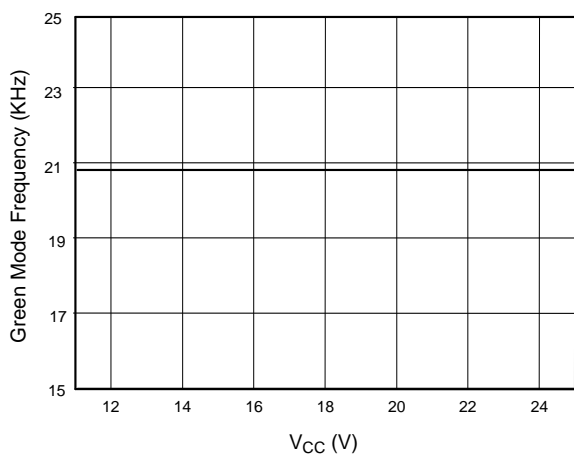

Fig. 6 Green Mode Frequency vs. VCC

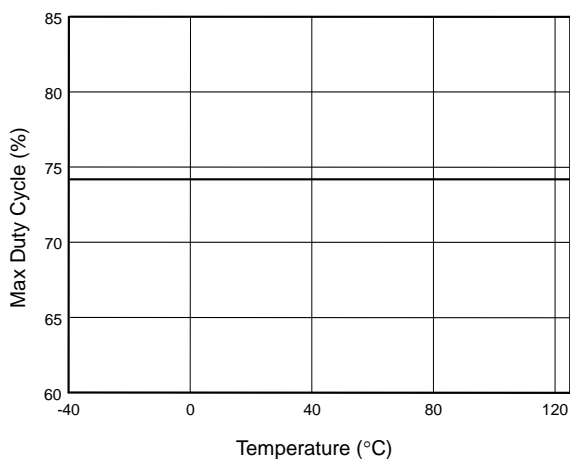

Fig. 7 Max Duty Cycle vs. Temperature

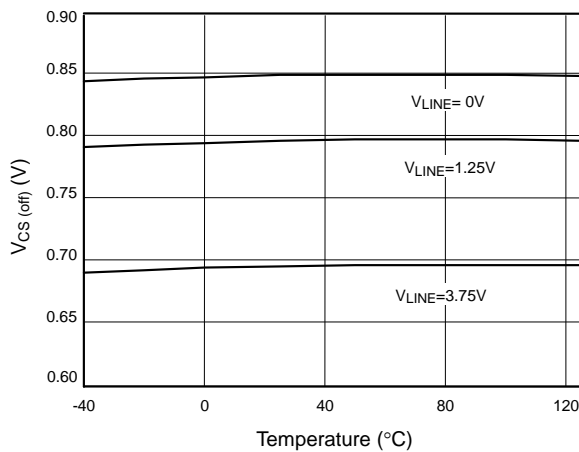

Fig. 8 Vcs (off) vs. Temperature

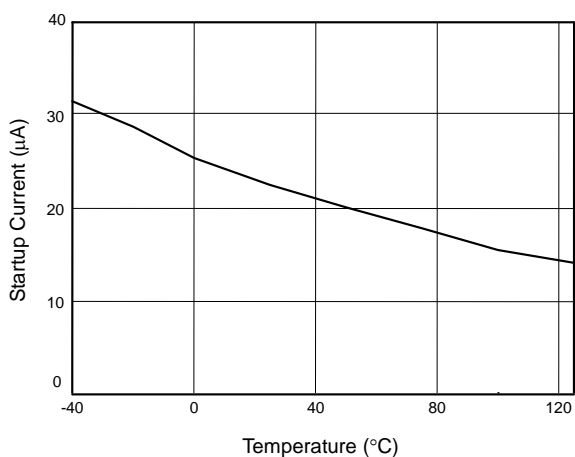

Fig. 9 Startup Current vs. Temperature

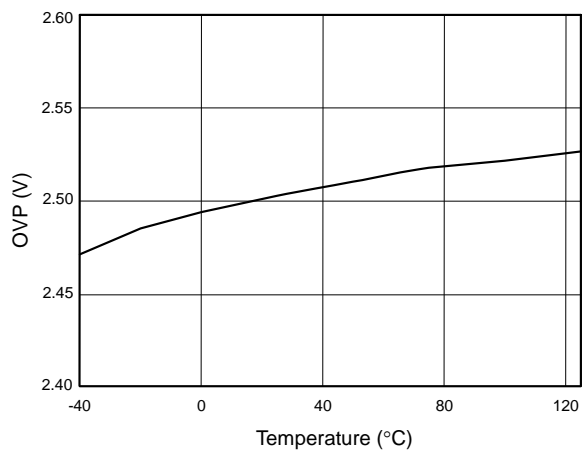

Fig. 10 OVP-Trip Level vs. Temperature

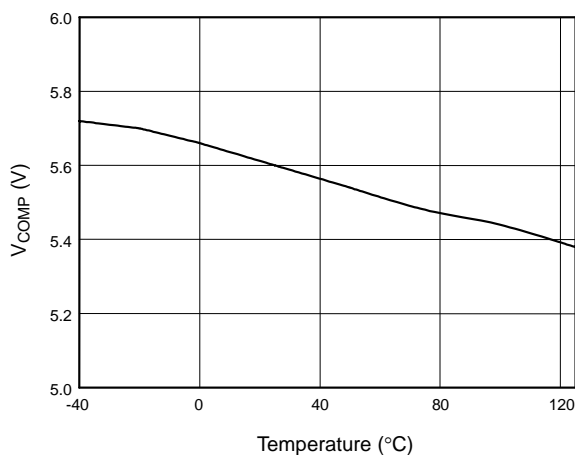

Fig. 11 V_{COMP} open-loop voltage vs. Temperature

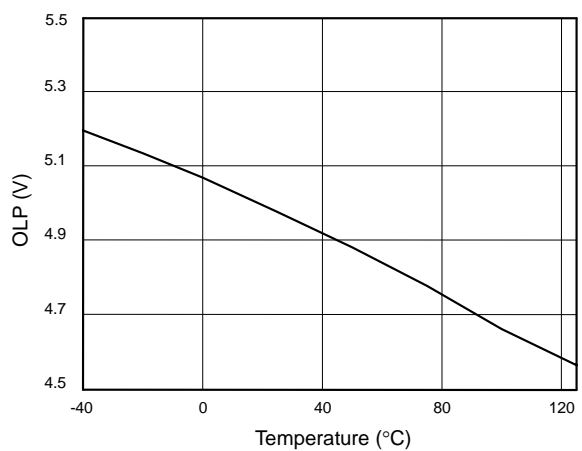

Fig. 12 OLP-Trip Level vs. Temperature

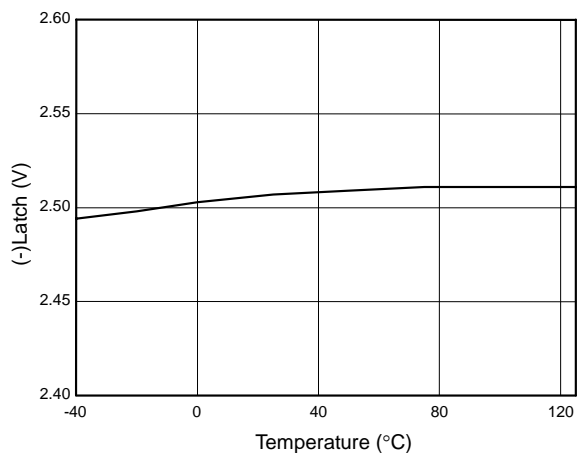

Fig. 13 (-)Latch Pin Off-Level vs. Temperature

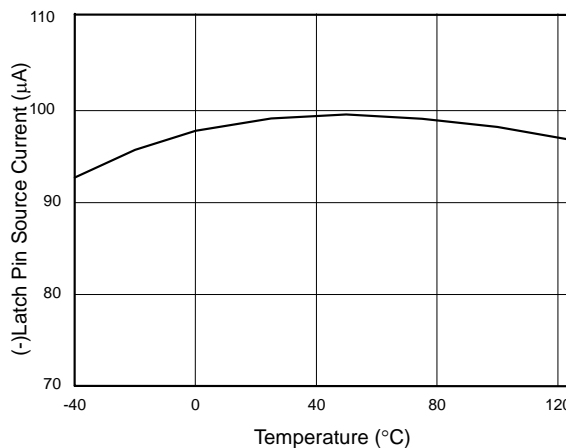

Fig. 14 (-)Latch Pin Source Current vs Temperature

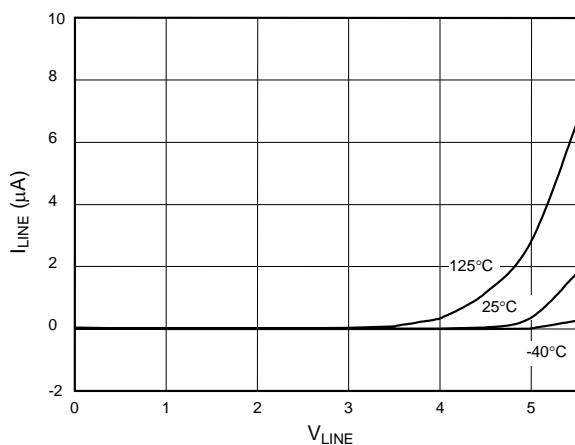

Fig. 15 V_{LINE} vs. I_{LINE}

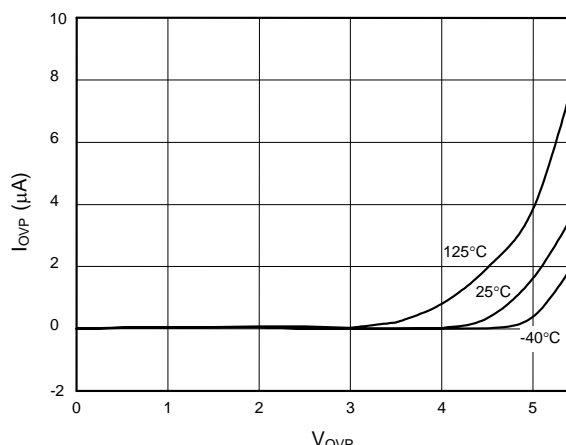

Fig. 16 V_{OVP} vs. I_{OVP}

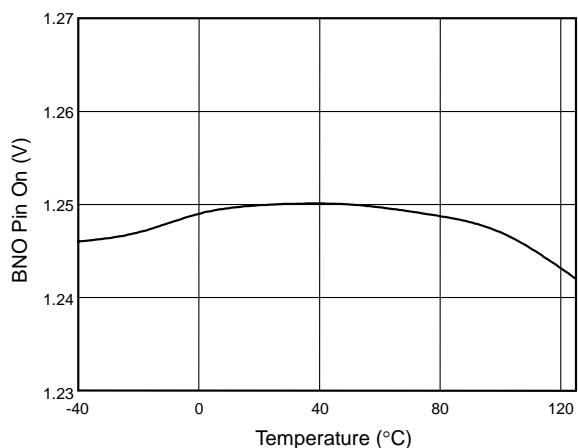

Fig. 17 BNO Pin On Level vs. Temperature

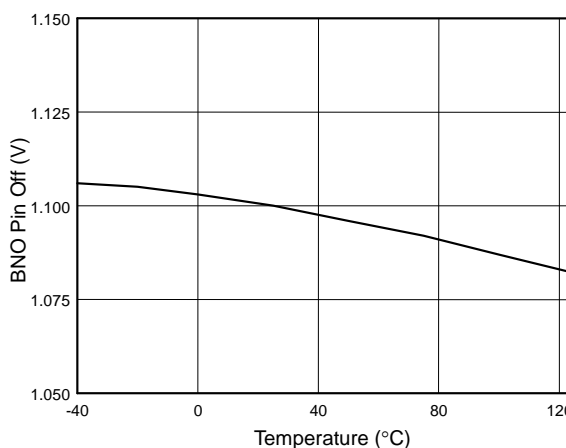

Fig. 18 BNO Pin Off Level vs. Temperature

Voltage Feedback Loop

The voltage feedback signal is provided from the TL431 in the secondary side through the photo-coupler to the COMP pin of LD7522. The input stage of LD7522, like the UC384X, is with 2 diodes voltage offset then feeding into the voltage divider with 1/3 ratio, that is,

$$V_{+(\text{PWM}_{\text{COMPARATOR}})} = \frac{1}{3} \times (V_{\text{COMP}} - 2V_F)$$

A pull-high resistor is embedded internally thus can be eliminated on the external circuit.

Dual-Oscillator Green-Mode Operation

There are many different topologies has been implemented in different chips for the green-mode or power saving requirements such as “burst-mode control”, “skipping-cycle mode”, “variable off-time control “...etc. The basic operation theory of all these approaches intended to reduce the switching cycles under light-load or no-load condition either by skipping some switching pulses or reduce the switching frequency.

By using this dual-oscillator control, the green-mode frequency can be well controlled and further to avoid the generation of audible noise.

Internal Slope Compensation

A fundamental issue of current mode control is the stability problem when its duty-cycle is operated more than 50%. To stabilize the control loop, the slope compensation is needed in the traditional UC384X design by injecting the ramp signal from the RT/CT pin through a coupling capacitor. In LD7522, the internal slope compensation circuit has been implemented to simplify the external circuit design.

Current Sensing, Leading-edge Blanking

The typical current mode PWM controller feedbacks both current signal and voltage signal to close the control loop and achieve regulation. The LD7522 detects the primary MOSFET current from the CS pin, which is not only for the peak current mode control but also for the pulse-by-pulse current limit. The maximum voltage threshold of the current sensing pin is set as 0.85V. Thus the MOSFET peak current can be calculated as:

$$I_{\text{PEAK}(\text{MAX})} = \frac{(0.85 - V_{\text{LINE_COMPENSATION}})}{R_S}$$

A 350nS leading-edge blanking (LEB) time is included in the input of CS pin to prevent the false-trigger from the current spike. However, the total pulse width of the turn-on spike is decided by the output power, circuit design and PCB layout. It is strongly recommended to adopt a smaller R-C filter (as shown in figure 22) to avoid the CS pin being damaged by the negative turn-on spike.

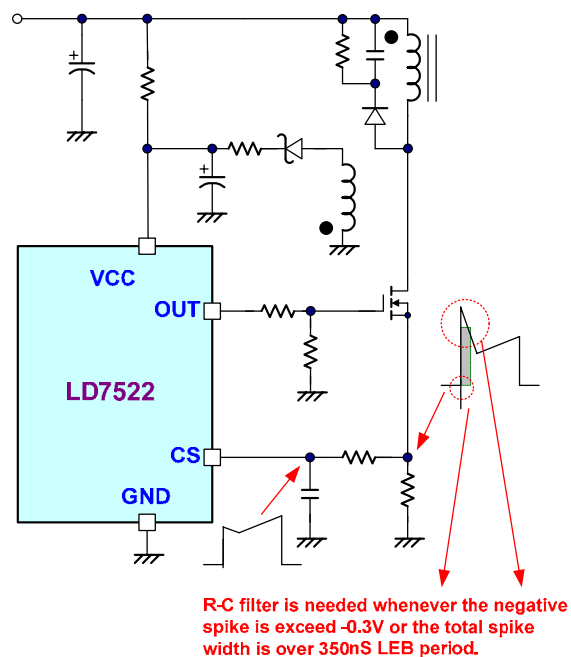

Fig. 21

Brownout Protection & Line Compensation

BNO pin plays 2 different roles in LD7522. The major function is to set the brownout protection point, and at the same time, it also provides the line compensation function like in LD7520.

Since the voltage on the BNO pin is proportional to the bulk capacitor voltage thus represented the line voltage. A brownout comparator is implemented to detect the abnormal line condition then shutdown the controller to prevent the damage. Figure 22 shows the operation. When V_{BNO} is lower than 1.25V, the gate output will be kept off even the V_{CC} already achieves $\text{UVLO}(\text{on})$, therefore the V_{CC} will be hiccup between $\text{UVLO}(\text{on})$ and $\text{UVLO}(\text{off})$. Until the line voltage is higher enough so that V_{BNO} is higher than 1.25V, the gate output will start switching when the next $\text{UVLO}(\text{on})$

is tripped. A hysteresis is implemented to prevent the false trigger during turn-on and turn-off.

On the other hand, LD7522 detects the voltage on the BNO pin to feed the line compensation signal on the current sense circuit. Figure 23 shows the circuit. Thanks to this implementation, the OCP level of high-line and low-line can be achieved to very closed point.

The voltage gain from the BNO voltage to line compensation is 0.04 (V/V). The relationship between BNO pin voltage and the line compensation is illustrated in figure 24.

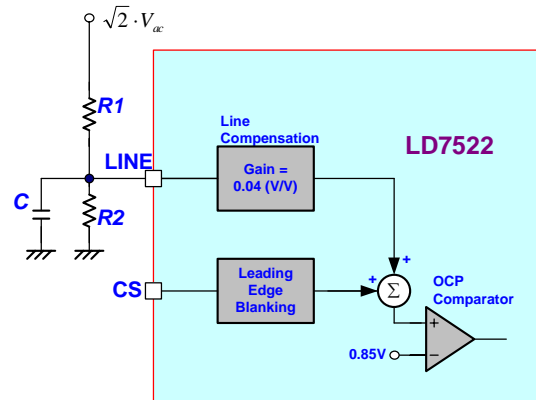

Fig. 23

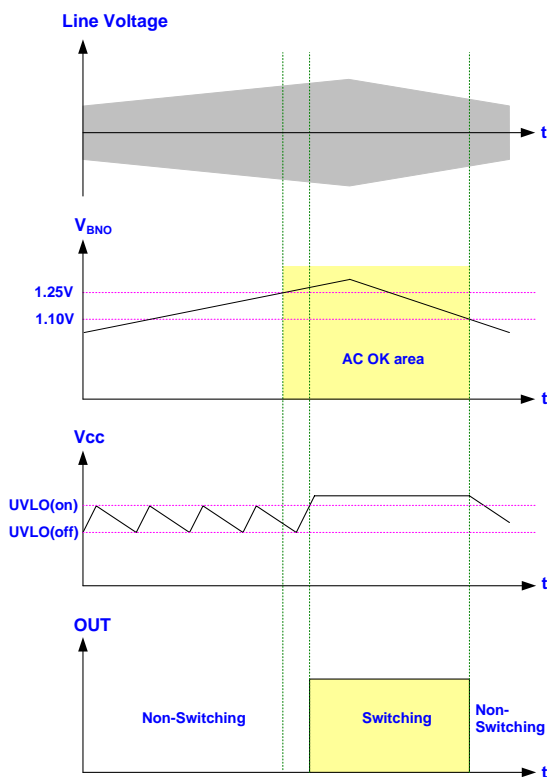

Fig. 22

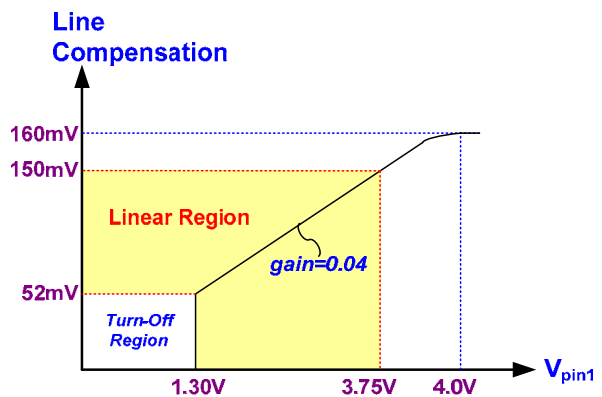

Fig. 24

Over Load Protection (OLP)

To protect the circuit from the damage during over load condition or short condition, a smart OLP function is implemented in the LD7522. Figure 26 shows the waveforms of the OLP operation. Under such fault condition, the feedback system will force the voltage loop toward the saturation and thus pull the voltage on COMP pin (VCOMP) to high. Whenever the VCOMP trips the OLP threshold 5.0V and keeps longer than 30mS, the protection is activated and then turns off the gate output to stop the switching of power circuit. The 30mS delay time is to prevent the false trigger from the power-on and turn-off transient.

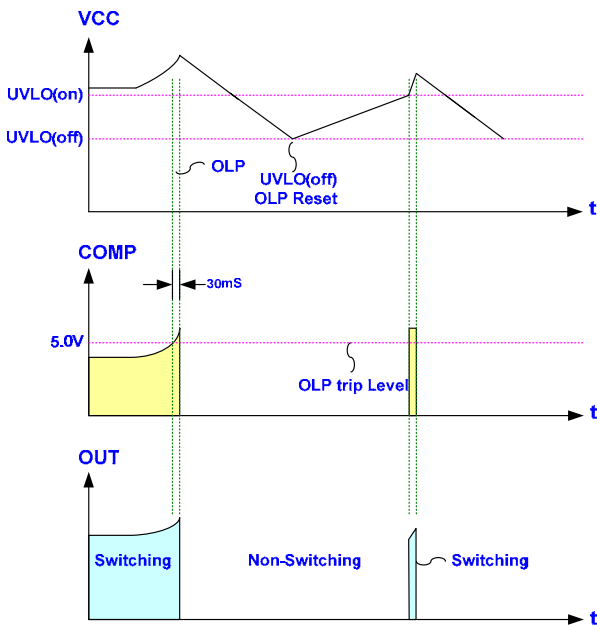

Fig. 25

By using such protection mechanism, the average input power can be reduced to very low level so that the component temperature and stress can be controlled within the safe operating area.

Over Voltage Protection (OVP)

The Vgs ratings of the nowadays power MOSFETs are most with maximum 30V. To prevent the component damage from the fault condition, LD7522 is implemented the protection through the OVP pin. Figure 26 and figure 27 show 2 different configurations to programming the OVP setting point --- zener detection and voltage divider. Figure 27 provided zero bias current under normal operation so that it will not affect the startup timing. But the tolerance of OVP trip point will be higher due to the distribution of the breakdown voltage of zener diode.

On the other hand, the circuit of figure 27 will get the benefits on the cost and that OVP accuracy but the value of R1 and R2 must be very high to avoid affecting the startup timing by the load effect.

As shown in figure 28, whenever the voltage on the OVP pin is higher than the threshold voltage 2.5V, the output gate drive circuit will be shutdown simultaneous thus to stop the switching of the power MOSFET. Whenever the voltage on the OVP pin gets back to lower than 2.5V, the output is

automatically returned to the normal operation on the next UVLO(on) level.

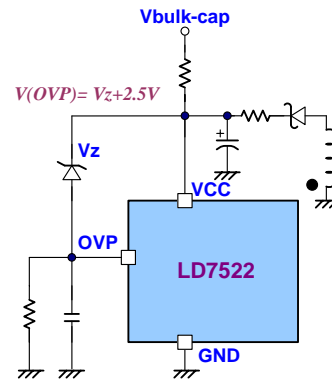

Fig. 26

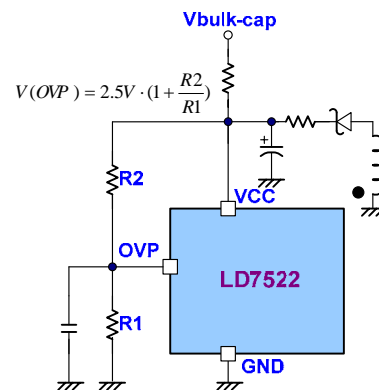

Fig. 27

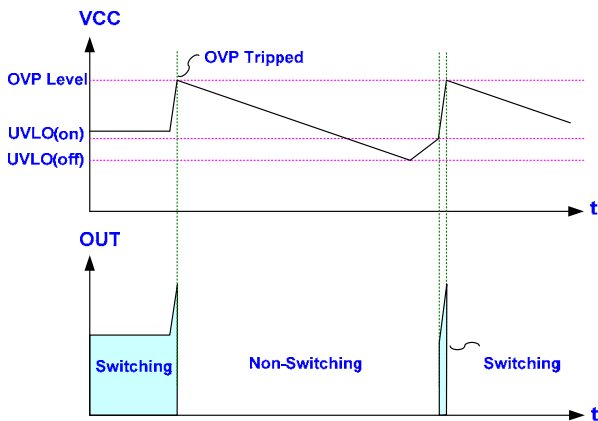

Fig. 28

(-)LATCH Pin and Over Temperature Protection (OTP) --- Latched Mode Protection

Under some abnormal conditions, the ambient temperature may be increased significantly and causes some damage on the components or further inhibits the dangerous. To prevent the power circuit damage from the system abnormal, the OTP is required. The OTP circuit is implemented by sensing the hot-spot of power circuit like power MOSFET or output rectifier. It can be easily achieved by connect a NTC on the (-)LATCH pin of LD7522. When the device temperature or ambient temperature rises high, the resistance of NTC will be decreased so that the voltage on the (-)LATCH pin will be

$$V_{(-)LATCH} = 100\mu A \times R_{NTC}$$

When the $V_{(-)LATCH}$ is lower than the threshold voltage (typical 2.5V), LD7522 will shutdown the gate output and then latch-off the power supply. On LD7522, the controller will be kept latched until the Vcc drop lower than 8V (power down reset) and the fault condition is removed. That means the gate output is still off even the abnormal condition is released. The only way to successfully re-start the circuit needs to meet 2 conditions. One is to cool down the circuit thus NTC resistance is increased then $V_{(-)LATCH}$ is higher than 3.5V. Another condition is to remove the AC power cord and begin another AC power-on recycling. The detail operation is depicted as figure 29.

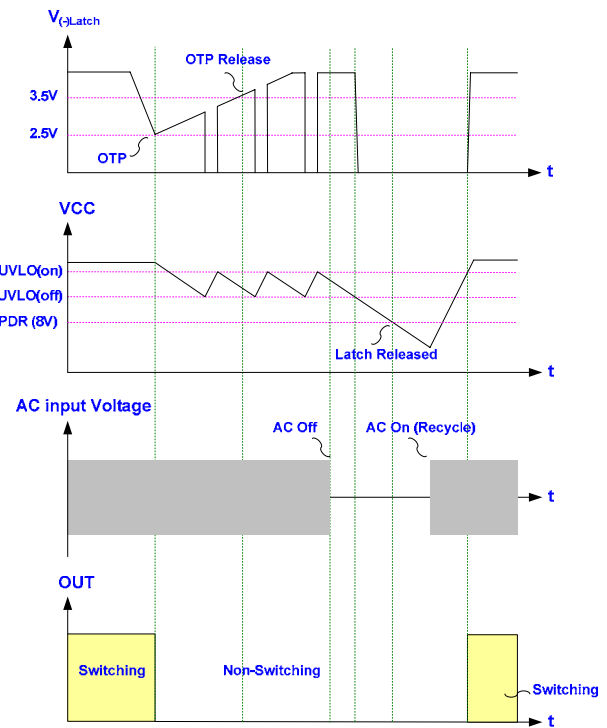

Fig. 29

Summary of Protections

There are several ways to control the on/off of LD7522. The details are listed as the table below.

	Turn Off	Operation
COMP	Comp Pin < 1.4V	Cycle by Cycle Mode Non-latch
OLP	Comp Pin > 5.0V	Hiccup Mode Non-latch Re-start after next UVLO(on)
OVP	OVP Pin > 2.5 V	
Brownout	BNO Pin < 1.25V with Hysteresis	
OTP	(-)LATCH Pin < 2.5V	Latch Mode

Table 1

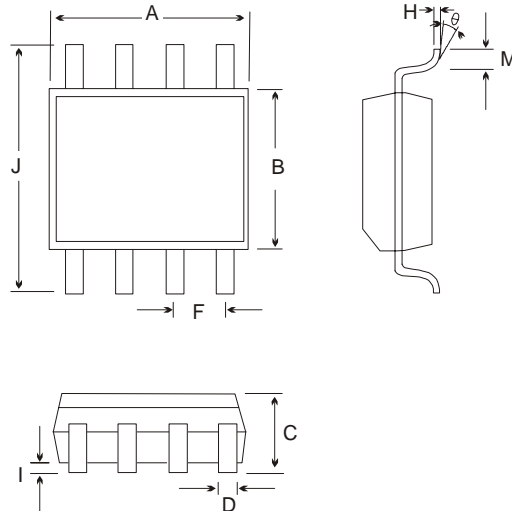
Package Information
SOP-8

Symbols	Dimensions in Millimeters		Dimensions in Inch	
	MIN	MAX	MIN	MAX
A	4.801	5.004	0.189	0.197
B	3.810	3.988	0.150	0.157
C	1.346	1.753	0.053	0.069
D	0.330	0.508	0.013	0.020
F	1.194	1.346	0.047	0.053
H	0.178	0.229	0.007	0.009
I	0.102	0.254	0.004	0.010
J	5.791	6.198	0.228	0.244
M	0.406	1.270	0.016	0.050
θ	0°	8°	0°	8°

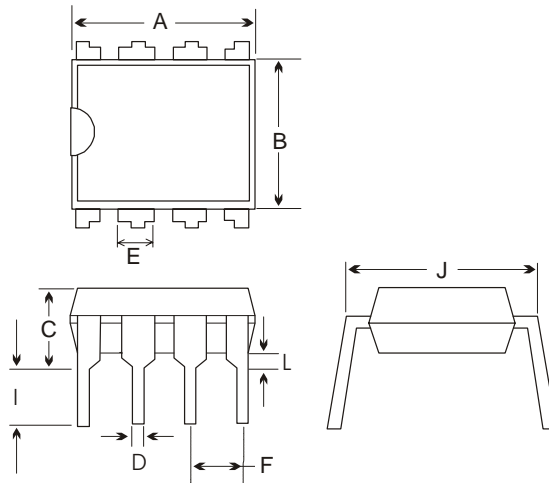
Package Information
DIP-8

Symbol	Dimension in Millimeters		Dimensions in Inches	
	Min	Max	Min	Max
A	9.017	10.160	0.355	0.400
B	6.096	7.112	0.240	0.280
C	-----	5.334	-----	0.210
D	0.356	0.584	0.014	0.023
E	1.143	1.778	0.045	0.070
F	2.337	2.743	0.092	0.108
I	2.921	3.556	0.115	0.140
J	7.366	8.255	0.29	0.325
L	0.381	-----	0.015	-----

Important Notice

Leadtrend Technology Corp. reserves the right to make changes or corrections to its products at any time without notice. Customers should verify the datasheets are current and complete before placing order.

Revision History

Rev.	Date	Change Notice
00	4/4/06	Original Specification.
01	8/31/06	Revision: Latch protection turn-on trip level, OVP trip level, and De-latch Vcc level Add: Application circuit & BOM list
02	12/8/2006	Revision: Block Diagram