

HIGH VOLTAGE IGNITION COIL DRIVER NPN POWER DARLINGTON

- VERY RUGGED BIPOLAR TECHNOLOGY
- HIGH OPERATING JUNCTION TEMPERATURE
- WIDE RANGE OF PACKAGES

APPLICATIONS

- HIGH RUGGEDNESS ELECTRONIC IGNITIONS

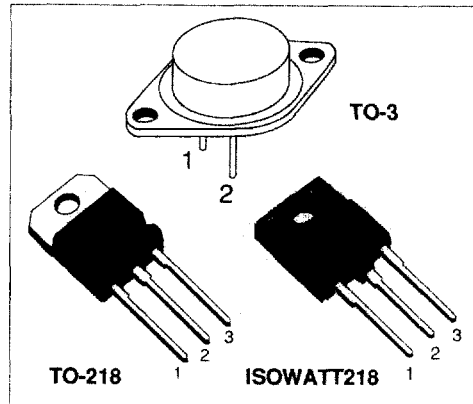

INTERNAL SCHEMATIC DIAGRAM

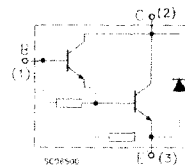

for TO-3
 Emitter: pin 2
 Base: pin 1
 Collector: tab

ABSOLUTE MAXIMUM RATINGS

Symbol	Parameter	Value			Unit
		BU931	BU931P	BU931PFI	
V_{CES}	Collector-Emitter Voltage ($V_{BE} = 0$)	500			V
V_{CEO}	Collector-Emitter Voltage ($I_B = 0$)	400			V
V_{EBO}	Emitter-Base Voltage ($I_C = 0$)	5			V
I_C	Collector Current	15			A
I_{CM}	Collector Peak Current	30			A
I_B	Base Current	1			A
I_{BM}	Base Peak Current	5			A
P_{tot}	Total Dissipation at $T_c = 25^\circ\text{C}$	175	135	60	W
T_{stg}	Storage Temperature	-65 to 200	-65 to 175	-65 to 175	$^\circ\text{C}$
T_j	Max. Operating Junction Temperature	200	175	175	$^\circ\text{C}$

THERMAL DATA

		TO-3	TO-218	ISOWATT218	
$R_{thj-case}$	Thermal Resistance Junction-case Max	1	1.1	2.5	°C/W

ELECTRICAL CHARACTERISTICS ($T_{case} = 25\text{ }^{\circ}\text{C}$ unless otherwise specified)

Symbol	Parameter	Test Conditions	Min.	Typ.	Max.	Unit
I_{CES}	Collector Cut-off Current ($V_{BE} = 0$)	$V_{CE} = 500\text{ V}$ $V_{CE} = 500\text{ V}$ $T_j = 125\text{ }^{\circ}\text{C}$			100 0.5	μA mA
I_{CEO}	Collector Cut-off Current ($I_B = 0$)	$V_{CE} = 450\text{ V}$ $V_{CE} = 450\text{ V}$ $T_j = 125\text{ }^{\circ}\text{C}$			100 0.5	μA mA
I_{EBO}	Emitter Cut-off Current ($I_C = 0$)	$V_{EB} = 5\text{ V}$			20	mA
$V_{CEO(sus)}^*$	Collector-Emitter Sustaining Voltage	$I_C = 100\text{ mA}$ $L = 10\text{ mH}$ $I_B = 0$ $V_{CLAMP} = \text{RATED } V_{CEO}$ (See FIG.4)	400			V
$V_{CE(sat)}^*$	Collector-Emitter Saturation Voltage	$I_C = 7\text{ A}$ $I_B = 70\text{ mA}$ $I_C = 8\text{ A}$ $I_B = 100\text{ mA}$ $I_C = 10\text{ A}$ $I_B = 250\text{ mA}$			1.6 1.8 1.8	V V V
$V_{BE(sat)}^*$	Base-Emitter Saturation Voltage	$I_C = 7\text{ A}$ $I_B = 70\text{ mA}$ $I_C = 8\text{ A}$ $I_B = 100\text{ mA}$ $I_C = 10\text{ A}$ $I_B = 250\text{ mA}$			2.2 2.4 2.5	V V V
h_{FE}^*	DC Current Gain	$I_C = 5\text{ A}$ $V_{CE} = 10\text{ V}$	300			
V_F	Diode Forward Voltage	$I_F = 10\text{ A}$			2.5	V
	Functional Test (see fig. 1)	$V_{CC} = 24\text{ V}$ $V_{clamp} = 400\text{ V}$ $L = 7\text{ mH}$	8			A
t_s t_f	INDUCTIVE LOAD Storage Time Fall Time (see fig. 3)	$V_{CC} = 12\text{ V}$ $V_{clamp} = 300\text{ V}$ $L = 7\text{ mH}$ $I_C = 7\text{ A}$ $I_B = 70\text{ mA}$ $V_{BE} = 0$ $R_{BE} = 47\text{ }\Omega$		15 0.5		μs μs

* Pulsed: Pulse duration = 300 μs , duty cycle 1.5 %

Safe Operating Area

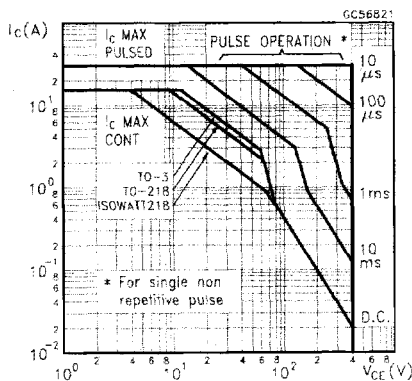

DC Current Gain

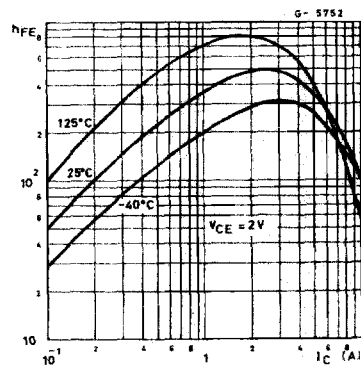

Collector Emitter Saturation Voltage

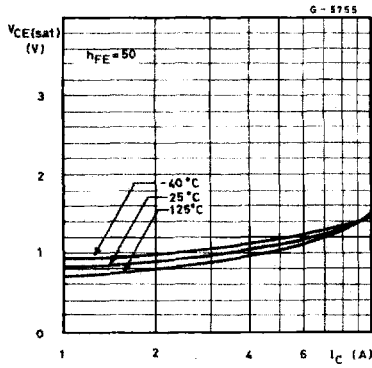

Collector Emitter Saturation Voltage

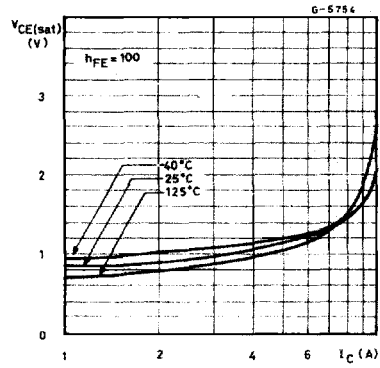

Collector Emitter Saturation Voltage

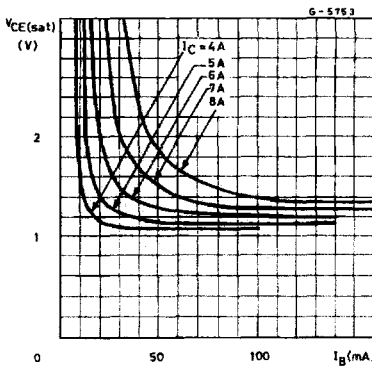

Base Emitter Saturation Voltage

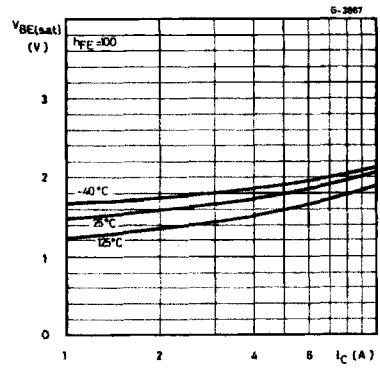

Base Emitter Saturation Voltage

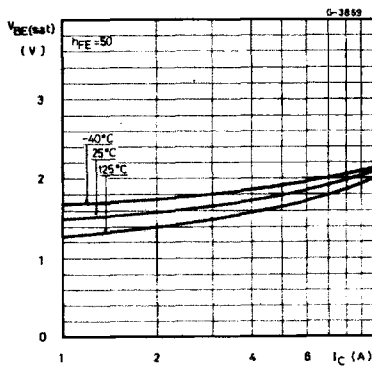

Switching Time Inductive Load

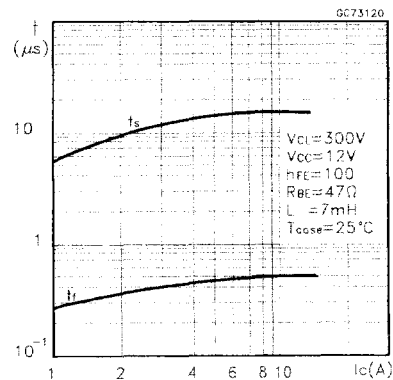

FIGURE 1: Functional Test Circuit

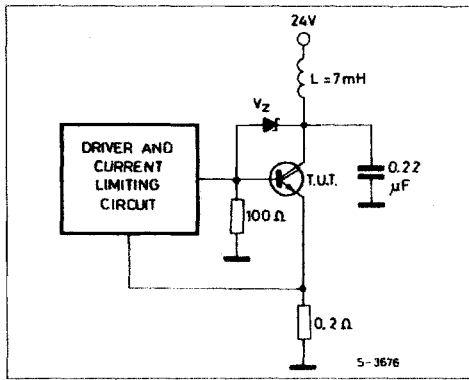

FIGURE 2: Functional Test Waveforms

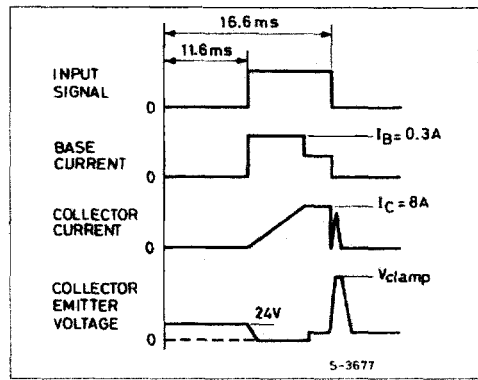

FIGURE 3: Switching Time Test Circuit

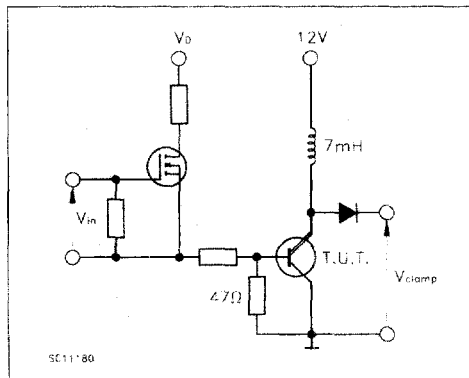

FIGURE 4: Sustaining Voltage Test Circuit

